



the smart approach to instrumentation™

Measurement Computing

10 Commerce Way
Norton, MA 02766

(508) 946-5100

Fax: (508) 946-9500

info@mccdaq.com

www.mccdaq.com

Extender 488 User's Manual

p/n Extender488-901

1996-1997 by Measurement Computing Corp.

Part No. Extender488-901

Printed in the United States of America

Warranty Information

Contact Measurement Computing by phone, fax, or e-mail in regard to warranty-related issues:
Phone: (508) 946-5100, fax: (508) 946-9500, e-mail: info@mccdaq.com

Limitation of Liability

Measurement Computing cannot be held liable for any damages resulting from the use or misuse of this product.

Copyright, Trademark, and Licensing Notice

All Measurement Computing documentation, software, and hardware are copyright with all rights reserved. No part of this product may be copied, reproduced or transmitted by any mechanical, photographic, electronic, or other method without Measurement Computing's prior written consent. IOtech product names are trademarked; other product names, as applicable, are trademarks of their respective holders. All supplied IOtech software (including miscellaneous support files, drivers, and sample programs) may only be used on one installation. You may make archival backup copies.

CE Notice



Many Measurement Computing products carry the CE marker indicating they comply with the safety and emissions standards of the European Community. When applicable these products have a Declaration of Conformity stating which specifications and operating conditions apply. You can view the Declarations of Conformity at www.mccdaq.com/legal.aspx (CE Information page).

Warnings, Cautions, Notes, and Tips



Refer all service to qualified personnel. This caution symbol warns of possible personal injury or equipment damage under noted conditions. Follow all safety standards of professional practice and the recommendations in this manual. Using this equipment in ways other than described in this manual can present serious safety hazards or cause equipment damage.



This warning symbol is used in this manual or on the equipment to warn of possible injury or death from electrical shock under noted conditions.



This ESD caution symbol urges proper handling of equipment or components sensitive to damage from electrostatic discharge. Proper handling guidelines include the use of grounded anti-static mats and wrist straps, ESD-protective bags and cartons, and related procedures.



This symbol indicates the message is important, but is not of a Warning or Caution category. These notes can be of great benefit to the user, and should be read.

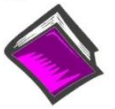

In this manual, the book symbol always precedes the words "Reference Note." This type of note identifies the location of additional information that may prove helpful. References may be made to other chapters or other documentation.



Tips provide advice that may save time during a procedure, or help to clarify an issue. Tips may include additional reference.

Specifications and Calibration

Specifications are subject to change without notice. Significant changes will be addressed in an addendum or revision to the manual. As applicable, the hardware is calibrated to published specifications. Periodic hardware calibration is not covered under the warranty and must be performed by qualified personnel as specified in this manual. Improper calibration procedures may void the warranty.

Table of Contents

Section 1	INTRODUCTION	Page
1.1	Description	1.1
1.2	Available Accessories	1.2
1.3	Extender488 Specifications	1.3
1.4	Extender488/F Specifications	1.4
1.5	Abbreviations	1.5
Section 2	GETTING STARTED	Page
2.1	Inspection	2.1
2.2	Extender488 Configuration	2.2
2.2.1	Extender488 Serial Baud Rate Selection	2.2
2.2.2	Extender488 Serial Data Format Selection	2.3
2.2.3	Extender488 Serial Port Cabling	2.4
2.3	Extender488/F Configuration	2.5
2.3.1	Extender488 Fiber Optic Connections	2.5
2.4	Operation	2.7
2.5	Parallel Poll Response Times	2.9
Section 3	IEEE 488 Primer	Page
3.1	History	3.1
3.2	General Structure	3.1
3.3	Send It To My Address	3.4
3.4	Bus Management Lines	3.4
3.4.1	Attention (ATN)	3.4
3.4.2	Interface Clear (IFC)	3.5
3.4.3	Remote Enable (REN)	3.5
3.4.4	End Or Identify (EOI)	3.5
3.4.5	Service Request (SRQ)	3.5
3.5	Handshake Lines	3.6
3.5.1	Data Valid (DAV)	3.6
3.5.2	Not Ready For Data (NRFD)	3.6
3.5.3	Not Data Accepted (NDAC)	3.6
3.6	Data Lines	3.7
3.7	Multiline Commands	3.7
3.7.1	Go To Local (GTL)	3.7
3.7.2	Listen Address Group (LAG)	3.8

Table of Contents

Section 3	IEEE 488 Primer	Page
3.7.3	Unlisten (UNL)	3.8
3.7.4	Talk Address Group (TAG)	3.8
3.7.5	Untalk (UNT)	3.8
3.7.6	Local Lockout (LLO)	3.8
3.7.7	Device Clear (DCL)	3.8
3.7.8	Selected Device Clear (SDC)	3.9
3.7.9	Serial Poll Disable (SPD)	3.9
3.7.10	Serial Poll Enable (SPE)	3.9
3.7.11	Group Execute Trigger (GET)	3.9
3.7.12	Take Control (TCT)	3.9
3.7.13	Secondary Command Group (SCG)	3.9
3.7.14	Parallel Poll Configure (PPC)	3.10
3.7.15	Parallel Poll Unconfigure (PPU)	3.10
3.8	More On Service Requests	3.10
3.8.1	Serial Poll	3.11
3.8.2	Parallel Poll	3.11
Section 4	SERVICE INFORMATION	Page
4.1	Factory Service	4.1
4.2	Theory of Operation	4.1
4.3	Extender488 Component Layout	4.2
4.4	Extender488/F Fiber Optic I/O Layout	4.3
4.4	Replaceable Parts List	4.4
Appendix A	IEEE Command and Address Messages	

INTRODUCTION

1.1 DESCRIPTION

The **Extender488s** enable IEEE 488 devices to be controlled up to 4,000 feet from the host computer. This overcomes the limit imposed by the IEEE 488 specification of 6 feet between any two devices, to a maximum of 60 feet total chained length. In addition, the **Extender488s** allows up to 30 devices to be on the bus, versus the 15 device limit imposed by the IEEE standard.

Two extenders are required to perform bus extension. The bus connecting the host computer, or controller, is the "local" bus. The bus to which control is extended is the "remote" bus. One of the **Extender488s** is required on each bus to accomplish IEEE bus extension.

Communication between extenders is accomplished with serial data transmission, using RS-422 data drivers and receivers with the **Extender488**. This differential serial data format provides high noise immunity and long-distance capability using low cost twisted pair wire.

The **Extender488/F** communicates serially over duplex fiber optic cables. Fiber optic transmission provides high noise immunity, low RFI emissions and long-distance capability.

Operation of the **Extender488s** is completely transparent to the system. The controller can access both local and remote devices in exactly the same manner, with the exception of Parallel Poll.

1.2 AVAILABLE ACCESSORIES

The following accessories are available from Measurement Computing for use with the **Extender488s**.

CA-7-1	1.5 foot IEEE 488 cable
CA-7-2	6 foot IEEE 488 cable
CA-7-3	6 foot IEEE 488 cable; shielded
CA-7-2	6 foot IEEE 488 cable; reverse entry
CA-18-X	Shielded serial cable with mating connectors for the Extender488; specify X in feet from 100 to 4000
CA-24-X	100 μ m/140 μ m duplex fiber optic cable with mating connectors for the Extender488/F; specify X in feet from 100 to 4000
CN-20	Right angle IEEE 488 adapter
CN-21	IEEE 488 connector extender
CN-22	IEEE 488 multi-tap bus strip; 4 connectors in parallel
CN-23	IEEE 488 panel mount feed-thru connector
114-0920	Additional Manual
Rack488-1	Rack mount kit; one Extender488 package
Rack488-2	Rack mount kit; two Extender488 packages
TR-2	External power supply for Extender488 105-125v; 50/60 Hz
TR-2E	External power supply for Extender488 210-250v; 50 Hz

Refer to the Measurement Computing catalog for those accessories not listed here.

1.3 Extender488 SPECIFICATIONS

IEEE 488-1978

Implementation: Proprietary transparent control and data transfers.
 Connector: Standard IEEE 488 connector with metric studs.

Serial Interface

EIA RS-422A: Balanced voltage on TxD and RxD.
 Connector: 9-pin Sub-D female.
 Character Set: Proprietary asynchronous bit serial.
 Baud Rate: Selectable 300, 600, 1200, 2400, 4800, 9600, 19,200 and 115,200.
 Data Format: Selectable 7 or 8 data bits; 1 stop bit; odd parity.
 Max. Cable Length: 1000 meters.

General

Data Rates: Specifications apply to data transfers after addressing has been established.

<u>Baud Rate</u>	<u>Data Rate</u> (bytes per second, avg)
300	13
600	26
1200	53
2400	105
4800	204
9600	385
19.2K	691
115.2K	3400

Indicators: LEDs for IEEE Talk, Listen, SRQ, Error and Power.
 Power: 105-125V or 210-250V; 50-60 Hz, 10 VA Max.
 Dimensions: 188mm deep x 140mm wide x 68mm high (7.39" x 5.5" x 2.68").
 Weight: 1.35 kg. (3.1 lbs).
 Environment: 0; - 50;C; 0 to 70% R.H. to 35;C.
 Linearly derate 3% R.H./;C from 35; to 50;C.
 Controls: Power Switch (external),
 Serial parameter switches (internal).

Specifications subject to change without notice.

1.4 Extender488/F SPECIFICATIONS

IEEE 488-1978

Implementation: Proprietary transparent control and data transfers.
Connector: Standard IEEE 488 connector with metric studs.

Fiber Optic Interface

Wavelength: 820 nanometers typical.
Connectors: SMA-905 series female.
Required Cable: Duplex 100µm, 140µm clad fiber optic.
200MHz-km bandwidth; 6 db/km max. attenuation.
Max. Cable Length: 1000 meters.

General

Data Rates: 3400 bytes per second typical.
Indicators: LEDs for IEEE Talk, Listen, SRQ, Error and Power.
Power: 105-125V or 210-250V; 50-60 Hz, 10 VA Max.
Dimensions: 188mm deep x 140mm wide x 68mm high
(7.39" x 5.5" x 2.68").
Weight: 1.55 kg. (3.6 lbs).
Environment: 0_i - 50_iC; 0 to 70% R.H. to 35_iC.
Linearly derate 3% R.H./_iC from 35_i to 50_iC.
Controls: Power Switch (external).

Specifications subject to change without notice.

1.5 ABBREVIATIONS

The following IEEE 488 abbreviations are used throughout this manual.

addr n	IEEE bus address "n"
ATN	Attention line
CA	Controller Active
CO	Controller
CR	Carriage Return
data	Data String
DCL	Device Clear
GET	Group Execute Trigger
GTL	Go To Local
LA	Listener Active
LAG	Listen Address Group
LF	Line Feed
LLO	Local Lock Out
MLA	My Listen Address
MTA	My Talk Address
PE	Peripheral
PPC	Parallel Poll Configure
PPU	Parallel Poll Unconfigure
SC	System Controller
SDC	Selected Device Clear
SPD	Serial Poll Disable
SPE	Serial Poll Enable
SRQ	Service Request
TA	Talker Active
TAD	Talker Address
TCT	Take Control
term	Terminator
UNL	Unlisten
UNT	Untalk
*	Unasserted

GETTING STARTED

2.1 INSPECTION

The **Extender488s** are carefully inspected, both mechanically and electrically, prior to shipment. When you receive the interface, carefully unpack all items from the shipping carton and check for any obvious signs of physical damage which may have occurred during shipment. Immediately report any damage found to the shipping agent. Remember to retain all shipping materials in the event that shipment back to the factory becomes necessary.

Every **Extender488** is shipped with the following....

- **Extender488** IEEE bus extender interface
- **TR-2 or TR-2E** Power Supply; TR-4 115V
TR-4E 220V
- **114-0920** Instruction Manual

Note: accessories ordered may be packaged and shipped separately

WARNING

The Extender488 requires a regulated external power supply with a maximum output of 5.25 volts! Using voltages above this level will result in damage to the interface. Use only power supplies provided by Measurement Computing.

2.2 Extender488 CONFIGURATION

The following describes the configuration necessary for the RS-422 **Extender488s**. If you are using the fiber optic extenders, refer to Section 2.3.

Two **Extender488s** are required to accomplish bus extension, with one connected directly to the **LOCAL** IEEE bus, and the other connected to the **REMOTE** IEEE bus.

Both local and remote extenders are identical. At power up, each extender monitors the Attention (ATN) and Remote Enable (REN) lines. The Error LED on each extender will blink indicating that ATN or REN has not yet been detected and that communication with the other extender has not yet been established. The first extender to detect either of these lines asserted declares itself the **LOCAL** extender and commands the other extender to declare itself the **REMOTE** extender. The Error LEDs will now stop blinking. From this moment on, the **LOCAL** extender will monitor all local bus activity and transmit this activity to the **REMOTE** extender. All activity detected by the **REMOTE** extender is also communicated back to the **LOCAL** extender.

2.2.1 Extender488 Serial Baud Rate Selection

The **Extender488** is shipped with the serial baud rate set to 115.2K baud. For most applications, this is the most efficient operating rate. However, if the extenders are to be located at extreme distances from each other, baud rates other than 115.2K can be selected. Selectable baud rates include 115.2K, 19.2K, 9600, 4800, 2400, 1200, 600, 300. Both extenders must be set to the same baud rate for proper operation.

To modify the baud rate, follow this simple procedure: Disconnect the power supply from the AC line and from the interface. Disconnect any IEEE or serial cables prior to disassembly.

WARNING

Never open the Extender488 case while it is connected to the AC line. Failure to observe this warning may result in equipment failure, personal injury or death.

Remove the four screws located in each corner of the rear panel. Hold the case firmly and pull the rear panel outward, noting the slot location of the main circuit board. Modify those parameters which are appropriate for your installation and reassemble the unit. Slide the main circuit board into the previously noted slot and finish reassembly by tightening the four screws into the rear panel.

Extender488 Baud Rate Selection

The diagram shows a 4-bit switch labeled S102 with positions 1, 2, 3, and 4. Position 4 is labeled 'OPEN'. A 'Switch Side View' diagram shows the switch in the '0' position. Below the switch is the text 'Default = 115200'. To the right is a table:

S102			Baud Rate
1	2	3	
0	0	0	300
1	0	0	600
0	1	0	1200
1	1	0	2400
0	0	1	4800
1	0	1	9600
0	1	1	19200
1	1	1	115200

2.2.2 Extender488 Serial Data Format Selection

The Extender488 is configurable for two data formats. The first, factory default, format is 8 data bits, 1 stop bit with odd parity. The number of data bits transmitted can be set to 7 by setting S102 switch 4 to the closed position. Even though the seven bit format is chosen, binary data can still be transferred over the Extender488's. There will, however, be a slight degradation in data transfer speeds with this format.

Extender488 Data Format Selection

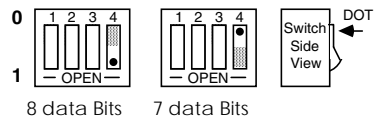

Note: Factory default is 8 data bits.

2.2.3 Extender488 Serial Port Cabling

The **Extender488** is shipped from the factory for RS-422 transmission medium, which prescribes differential receivers for high noise immunity. To insure signal integrity, only use shielded cable for the serial port connections. If you are not using a cable provided by the factory, below is the appropriate connections for proper operation.

Local Extender		Remote Extender	
Signal	Pin #	Pin #	Signal
Receive Data -	1	← 6	Transmit Data -
Receive Data +	2	← 7	Transmit Data +
Ground (shield)	5	← 5	Ground (shield)
Transmit Data -	6	→ 1	Receive Data -
Transmit Data +	7	→ 2	Receive Data +

2.3 Extender488/F CONFIGURATION

The following describes the configuration necessary for the fiber optic **Extender488/Fs**. If you are using the RS-422 extenders, refer to Section 2.2.

Two **Extender488/Fs** are required to accomplish bus extension, with one connected directly to the **LOCAL** IEEE bus, and the other connected to the **REMOTE** IEEE bus.

Both local and remote extenders are identical. At power up, each extender monitors the Attention (ATN) and Remote Enable (REN) lines. The Error LED on each extender will blink indicating that ATN or REN has not yet been detected and that communication with the other extender has not yet been established. The first extender to detect either of these lines asserted declares itself the **LOCAL** extender and commands the other extender to declare itself the **REMOTE** extender. The Error LEDs will now stop blinking. From this moment on, the **LOCAL** extender will monitor all local bus activity and transmit this activity to the **REMOTE** extender. All activity detected by the **REMOTE** extender is also communicated back to the **LOCAL** extender.

WARNING

There are no user serviceable parts or user selectable parameters inside the Extender488/F case. Refer all servicing to qualified repair personnel. Refer to Section 4 for additional information.

2.3.1 Extender488/F Fiber Optic Connections

The **Extender488/F** requires duplex fiber optic cabling. Most cable manufacturers mark the two connectors at each end of the duplex cable with a "T" and an "R" to distinguish which to connect to the transmitter (T) and which to connect to the receiver (R). Connect the fiber optic cables as shown below. The Transmitter of #1 is connected to the receiver of #2 and visa verse.

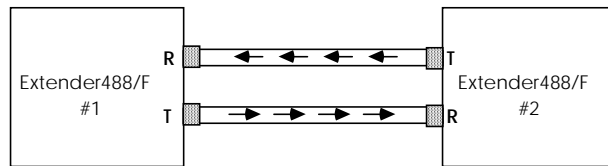

There are several recommended precautions you should take to ensure years of trouble free operation.

1. Treat the fiber optic transmitter, receiver and cabling ends as you would treat an expensive camera lens. Good system performance requires clean port optics and cable ferrules to avoid obstructing the optical path.
2. Clean compressed air is often all that's needed to remove dirt particles from the optic transmitters and receivers. Standard lens cleaning tissues or cotton swabs soaked with methanol or Freon also work well for cleaning cable ferrules. Take care to avoid splashing methanol or Freon on case parts.
3. When not in use, replace **Extender488/F** optical transmitter and receiver protection caps. Also ensure cable ferrule protection caps are also replaced.
4. When pulling optic cable through conduits of walls, NEVER use the connectors as a link to the pulling lead. Make sure that the cable is loose in the conduit after installation. If the cable is pulled tight on a corner, transmission loss may be increased significantly.
5. When seating connectors in the transmitter and receiver, some rotation of the connector may be necessary to achieve satisfactory transmission.

2.4 OPERATION

After configuring the **Extender488s** attaching the serial port or fiber optic cabling, plug the power supply connector into the rear jack on the interface.

CAUTION

Never install the power supply into the interface while it is connected to AC line power. Failure to observe this caution may result in damage to the Extender488. Only a supply with regulated +5 volt output should be used.

WARNING

The power supply provided with the interface is intended for INDOOR USE ONLY. Failure to observe this warning could result in equipment failure, personal injury or death.

After installing the power supply connector into the interface, plug the power supply into the AC line power. Place the rear panel power switch in the **ON** [1] position. All front panel indicators should light for approximately one second while the **Extender488** performs an internal ROM and RAM self check. At the end of the power-on sequence, the ERROR LED should continue to blink, indicating that communications with another extender has not been established. Now repeat the above procedure with the second extender, and observe the same results. If any of the following LED conditions exist after power-on, a failure has occurred.

SYMPTOM

All lights remain on
All lights blink continually
No LEDs blink

FAILURE

ROM test has failed
RAM test has failed
Power supply has failed

If any of the symptoms shown occur, cycle the power switch on the **Extender488** to be sure of the problem. If the problem is unresolved, refer to the Service Information section of this manual.

WARNINGThe **Extender488** makes its earth ground connection through the IEEE interface cable. Each extender must be connected to at least one IEEE device which is earth ground referred. Failure to do so may allow the **Extender488** to float to a voltage away from ground. This could result in damage to the interface, personal injury or death.

If proper operation is obtained, turn-off the **Extender488** power switch and connect the other IEEE devices to each of the **Extender488**'s IEEE ports. Connect the local extender to the remote extender via the serial or fiber optic cable. Apply power to all devices in the system. If the **Extender488** ERROR LED continues to blink after the power-on sequence, this indicates one of two possible conditions: either the system controller has not yet asserted the Attention line, or communication with the mating extender has not yet been established. Be sure both extenders are powered-on, the cabling has been installed, and the controller has asserted Attention before assuming there is a problem.

Once all IEEE devices have been connected and powered on, the **Extender488** will allow the system controller to command up to 13 IEEE devices on its local bus (in addition to itself and the local extender), and up to 14 IEEE devices on the remote bus (in addition to the remote extender). The extenders have no address of their own, and therefore will operate completely transparent to the system (with the exception of parallel poll). Be careful not to have two IEEE devices with the same address connected to either remote or local buses. Failure to do so will result in the bus 'locking up' when one of the devices is accessed.

2.5 PARALLEL POLL RESPONSE TIMES

The Parallel Poll function is the only extended bus transaction which is not completely transparent to your system. This is because the speed at which data is transferred serially is slower than the IEEE specification for Parallel Poll response. Consequently, it is necessary for the controller to perform two Parallel Polls.

When the local extender detects the parallel poll, it outputs the most recent Parallel Poll information to the controller on the local bus. This data should be discarded by the controller because it is not current. After receiving a Parallel Poll, the local extender commands the remote extender to perform a Parallel Poll, and returns the remote Parallel Poll data byte to the local extender. The bus controller should now perform another Parallel Poll, and use this data as the valid Parallel Poll byte. The following table describes the minimum times the controller should wait between consecutive Parallel Polls in order to assure valid data on the second poll.

Extender488 Parallel Poll Response Times

Baud Rate	Delay (typ)
115200	1 msec
19200	3 msec
9600	8 msec
4800	13 msec
2400	24 msec
1200	48 msec
600	92 msec
300	200 msec

The minimum time the controller should wait with the **Extender488/F** between consecutive Parallel Polls is 1 millisecond.

IEEE 488 Primer

3.1 HISTORY

The **IEEE 488** bus is an instrumentation communication bus adopted by the Institute of Electrical and Electronic Engineers in 1975 and revised in 1978. The **Extender488** and the **Extender488/F** conform to this most recent revision designated **IEEE 488-1978**.

Prior to the adoption of this standard, most instrumentation manufacturers offered their own versions of computer interfaces. This placed the burden of system hardware design on the end user. If his application required the products of several different manufacturers, then he might need to design several different hardware and software interfaces. The popularity of the **IEEE 488** interface (sometimes called the **General Purpose Interface Bus** or **GPIB**) is due to the total specification of the electrical and mechanical interface as well as the data transfer and control protocols. The use of the **IEEE 488** standard has moved the responsibility of the user from design of the interface to design of the high level software that is specific to the measurement application.

3.2 GENERAL STRUCTURE

The main purpose of the **GPIB** is to transfer information between two or more devices. A device can either be an instrument or a computer. Before any information transfer can take place, it is first necessary to specify which will do the talking (send data) and which devices will be allowed to listen (receive data). The decision of who will talk and who will listen usually falls on the **System Controller** which is, at power on, the **Active Controller**.

The **System Controller** is similar to a committee chairman. On a well run committee, only one person may speak at a time and the chairman is responsible for recognizing members and allowing them to have their say. On the bus, the device which is recognized to speak is the **Active Talker**. There can only be one Talker at a time if the information transferred is to be clearly understood by all. The act of "giving the floor" to that device is called **Addressing to Talk**. If the committee chairman can not attend the meeting, or if other matters require his attention, he can appoint an acting chairman to take control of the proceedings. For the **GPIB**, this device becomes the **Active Controller**.

At a committee meeting, everyone present usually listens. This is not the case with the **GPIB**. The **Active Controller** selects which devices will listen and commands all other devices to ignore what is being transmitted. A device is instructed to listen by being **Addressed to Listen**. This device is then referred to as an **Active Listener**. Devices which are to ignore the data message are instructed to **Unlisten**.

The reason some devices are instructed to **Unlisten** is quite simple. Suppose a college instructor is presenting the day's lesson. Each student is told to raise their hand if the instructor has exceeded their

ability to keep up while taking notes. If a hand is raised, the instructor stops his discussion to allow the slower students the time to catch up. In this way, the instructor is certain that each and every student receives all the information he is trying to present. Since there are a lot of students in the classroom, this exchange of information can be very slow. In fact, the rate of information transfer is no faster than the rate at which the slowest note-taker can keep up. The instructor, though, may have a message for one particular student. The instructor tells the rest of the class to ignore this message (**Unlisten**) and tells it to that one student at a rate which he can understand. This information transfer can then happen much quicker, because it need not wait for the slowest student.

The **GPIB** transfers information in a similar way. This method of data transfer is called **handshaking**. More on this later.

For data transfer on the **IEEE 488**, the **Active Controller** must

- a) **Unlisten** all devices to protect against eavesdroppers.
- b) Designate who will **talk** by **addressing** a device to **talk**.
- c) Designate all the devices who are to **listen** by **addressing** those devices to **listen**.
- d) Indicate to all devices that the data transfer can take place.

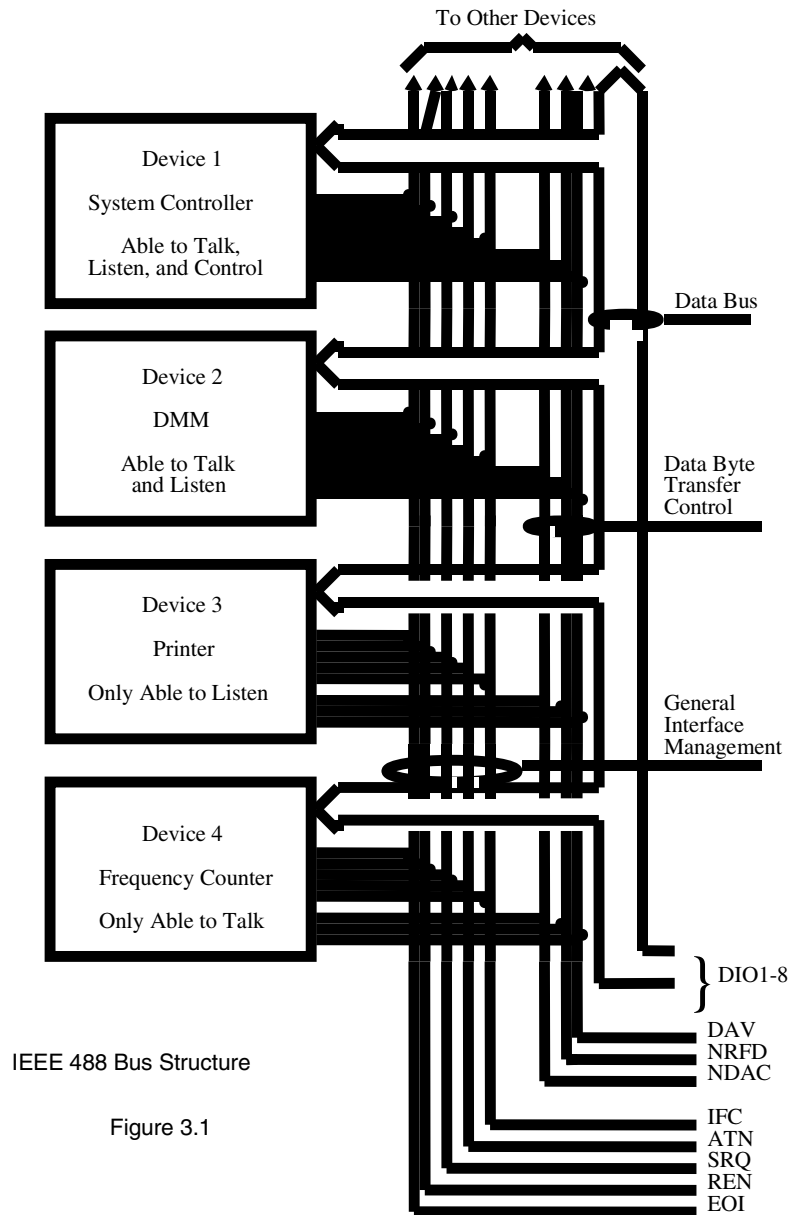

Figure 3.1

3.3 SEND IT TO MY ADDRESS

In the previous discussion, the terms **Addressed to Talk** and **Addressed to Listen** were used. These terms require some clarification.

The **IEEE 488** standard permits up to 15 devices to be configured within one system. Each of these devices must have a unique address to avoid confusion. In a similar fashion, every building in town has a unique address to prevent one home from receiving another home's mail. Exactly how each device's address is set is specific to the product's manufacturer. Some are set by DIP switches in hardware, others by software. Consult the manufacturer's instructions to determine how to set the address.

Addresses are sent with **universal (multiline)** commands from the **Active Controller**. These commands include **My Listen Address (MLA)**, **My Talk Address (MTA)**, **Talk Address Group (TAG)**, and **Listen Address Group (LAG)**.

3.4 BUS MANAGEMENT LINES

Five hardware lines on the **GPIB** are used for bus management. Signals on these lines are often referred to as **uniline** (single line) commands. The signals are active low, i.e. a low voltage represents a logic "1" (asserted), and a high voltage represents a logic "0" (unasserted).

3.4.1 Attention (ATN)

ATN is one of the most important lines for bus management. If Attention is asserted, then the information contained on the data lines is to be interpreted as a multiline command. If it is not, then that information is to be interpreted as data for the **Active Listeners**. The **Active Controller** is the only bus device that has control of this line.

3.4.2 Interface Clear (IFC)

The **IFC** line is used only by the **System Controller**. It is used to place all bus devices in a known state. Although device configurations vary, the **IFC** command usually places the devices in the Talk and Listen Idle states (neither **Active Talker** nor **Active Listener**).

3.4.3 Remote Enable (REN)

When the **System Controller** sends the **REN** command, bus devices will respond to remote operation. Generally, the **REN** command should be issued before any bus programming is attempted. Only the **System Controller** has control of the **Remote Enable** line.

3.4.4 End or Identify (EOI)

The **EOI** line is used to signal the last byte of a multibyte data transfer. The device that is sending the data asserts **EOI** during the transfer of the last data byte. The **EOI** signal is not always necessary as the end of the data may be indicated by some special character such as carriage return.

The **Active Controller** also uses **EOI** to perform a **Parallel Poll** by simultaneously asserting **EOI** and **ATN**.

3.4.5 Service Request (SRQ)

When a device desires the immediate attention of the **Active Controller** it asserts **SRQ**. It is then the Controller's responsibility to determine which device requested service. This is accomplished with a **Serial Poll** or a **Parallel Poll**.

3.5 HANDSHAKE LINES

The **GPIB** uses three handshake lines in an "I'm ready - Here's the data - I've got it" sequence. This handshake protocol assures reliable data transfer, at the rate determined by the slowest Listener. One line is controlled by the Talker, while the other two are shared by all Active Listeners. The handshake lines, like the other **IEEE 488** lines, are active low.

3.5.1 Data Valid (DAV)

The **DAV** line is controlled by the **Talker** . The **Talker** verifies that **NDAC** is asserted (active low) which indicates that all Listeners have accepted the previous data byte transferred. The **Talker** then outputs data on the bus and waits until **NRFD** is unasserted (high) which indicates that all Addressed Listeners are ready to accept the information. When **NRFD** and **NDAC** are in the proper state, the **Talker** asserts **DAV** (active low) to indicate that the data on the bus is valid.

3.5.2 Not Ready for Data (NRFD)

This line is used by the **Listeners** to inform the **Talker** when they are ready to accept new data. The **Talker** must wait for each **Listener** to unassert this line (high) which they will do at their own rate when they are ready for more data. This assures that all devices that are to accept the information are ready to receive it.

3.5.3 Not Data Accepted (NDAC)

The **NDAC** line is also controlled by the **Listeners** . This line indicates to the **Talker** that each device addressed to listen has accepted the information. Each device releases **NDAC** (high) at its own rate, but the **NDAC** will not go high until the slowest Listener has accepted the data byte.

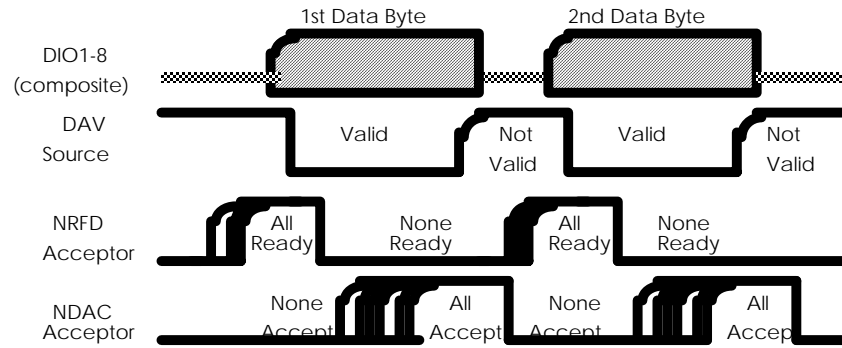

IEEE Bus Handshaking

3.6 DATA LINES

The **GPIB** provides eight data lines for a bit parallel/byte serial data transfer. These eight data lines use the convention of **DIO1** through **DIO8** instead of the binary designation of **D0** to **D7**. The data lines are bidirectional and are active low.

3.7 MULTILINE COMMANDS

Multiline (bus) commands are sent by the **Active Controller** over the data bus with **ATN** asserted. These commands include addressing commands for talk, listen, Untalk and Unlisten.

3.7.1 Go To Local (GTL)

This command allows the selected devices to be manually controlled. (\$01)

3.7.2 Listen Address Group (LAG)

There are 31 (0 to 30) listen addresses associated with this group. The 3 most significant bits of the data bus are set to 001 while the 5 least significant bits are the address of the device being told to listen.

3.7.3 Unlisten (UNL)

This command tells all bus devices to Unlisten. The same as Unaddressed to Listen. (\$3F)

3.7.4 Talk Address Group (TAG)

There are 31 (0 to 30) talk addresses associated with this group. The 3 most significant bits of the data bus are set to 010 while the 5 least significant bits are the address of the device being told to talk.

3.7.5 Untalk (UNT)

This command tells bus devices to Untalk. The same as Unaddressed to Talk. (\$5F)

3.7.6 Local Lockout (LLO)

Issuing the **LLO** command prevents manual control of the instrument's functions. (\$11)

3.7.7 Device Clear (DCL)

This command causes all bus devices to be initialized to a pre-defined or power up state. (\$14)

3.7.8 Selected Device Clear (SDC)

This causes a single device to be initialized to a pre-defined or power up state. (\$04)

3.7.9 Serial Poll Disable (SPD)

The **SPD** command disables all devices from sending their Serial Poll status byte. (\$19)

3.7.10 Serial Poll Enable (SPE)

A device which is Addressed to Talk will output its Serial Poll status byte after **SPE** is sent and **ATN** is unasserted. (\$18)

3.7.11 Group Execute Trigger (GET)

This command usually signals a group of devices to begin executing a triggered action. This allows actions of different devices to begin simultaneously. (\$08)

3.7.12 Take Control (TCT)

This command passes bus control responsibilities from the current **Controller** to another device which has the ability to control. (\$09)

3.7.13 Secondary Command Group (SCG)

These are any one of the 32 possible commands (0 to 31) in this group. They must immediately follow a talk or listen address. (\$60 to \$7F)

3.7.14 Parallel Poll Configure (PPC)

This configures devices capable of performing a **Parallel Poll** as to which data bit they are to assert in response to a **Parallel Poll**. (\$05)

3.7.15 Parallel Poll Unconfigure (PPU)

This disables all devices from responding to a **Parallel Poll**. (\$15)

3.8 MORE ON SERVICE REQUESTS

Most of the commands covered, both uniline and multiline, are the responsibility of the **Active Controller** to send and the bus devices to recognize. Most of these happen routinely by the interface and are totally transparent to the system programmer. Other commands are used directly by the user to provide optimum system control. Of the uniline commands, **SRQ** is very important to the test system and the software designer has easy access to this line by most devices. Service Request is the method by which a bus device can signal to the **Controller** that an event has occurred. It is similar to an interrupt in a microprocessor based system.

Most intelligent bus peripherals have the ability to assert **SRQ**. A DMM might assert it when its measurement is complete, if its input is overloaded or for any of an assortment of reasons. A power supply might **SRQ** if its output has current limited. This is a powerful bus feature that removes the burden from the **System Controller** to periodically inquire, "Are you done yet?". Instead, the **Controller** says, "Do what I told you to do and let me know when you're done" or "Tell me when something is wrong."

Since **SRQ** is a single line command, there is no way for the **Controller** to determine which device requested the service without additional information. This information is provided by the multiline commands for **Serial Poll** and **Parallel Poll**.

3.8.1 Serial Poll

Suppose the **Controller** receives a service request. For this example, let's assume there are several devices which could assert **SRQ**. The **Controller** issues an **SPE** (Serial Poll enable) command to each device sequentially. If any device responds with DIO7 asserted it indicates to the **Controller** that it was the device that asserted **SRQ**. Often times the other bits will indicate why the device wanted service. This **Serial Polling** sequence, and any resulting action, is under control of the software designer.

3.8.2 Parallel Poll

The **Parallel Poll** is another way the **Controller** can determine which device requested service. It provides the who but not necessarily the why. When bus devices are configured for Parallel Poll, they are assigned one bit on the data bus for their response. By using the Status bit, the logic level of the response can be programmed to allow logical OR/AND conditions on one data line by more than one device. When **SRQ** is asserted, the **Controller** (under user's software) conducts a **Parallel Poll**. The **Controller** must then analyze the eight bits of data received to determine the source of the request. Once the source is determined, a **Serial Poll** might be used to determine the why.

Of the two polling types, the **Serial Poll** is the most popular due to its ability to determine the who and why. In addition, most devices support **Serial Poll** only.

SERVICE INFORMATION

4.1 Factory Service

Measurement Computing maintains a factory service center in Norton, Massachusetts. If problems are encountered in using the **Extender488**, you should first telephone the factory. Many problems can be resolved by discussing the problem with our applications department. If the problem cannot be solved by this method, you will be instructed as to the proper return procedure.

4.2 Theory of Operation

At the heart of the **Extender488** is a 6809 microprocessor [U101] supported by 8K bytes of firmware EPROM [U102 (2764)] and 8K bytes of static RAM [U103 (6264)]. A counter [U105 (65C22)] contained in the VIA is used to generate real time interrupts for the firmware operating system. The front panel annunciators are driven by the VIA through an inverter/driver [U113 (74LS04)].

Serial communication to the mating **Extender488** is accomplished by a UART [U105] thru the RS-422 receiver [U112] and driver [U111]. For the **Extender488/F** it is accomplished by the UART and fiber optic transmitter [U202] and receiver [U203].

The IEEE 488 bus is monitored by a 9914A IEEE bus device [U106]. Circuitry surrounding the 9914A (U115 and U116) enables the device to monitor all bus activity, and to initiate bus activity when required.

Decoding of the microprocessor address space is accomplished with a programmed PAL [U110 (16L8)]. Below is the memory space allocation.

<u>Address</u>	<u>Device</u>	<u>Part Number</u>	<u>Function</u>
\$6000-\$7FFF	U103	6264	Static RAM
\$A000-\$A007	U106	9914A	IEEE Controller
\$A800-\$A803	U105	6551	UART
\$B000-\$B00F	U104	65C22	VIA
\$E000-\$FFFF	U102	2764	Programmed EPROM

4.3 Extender488 COMPONENT LAYOUT

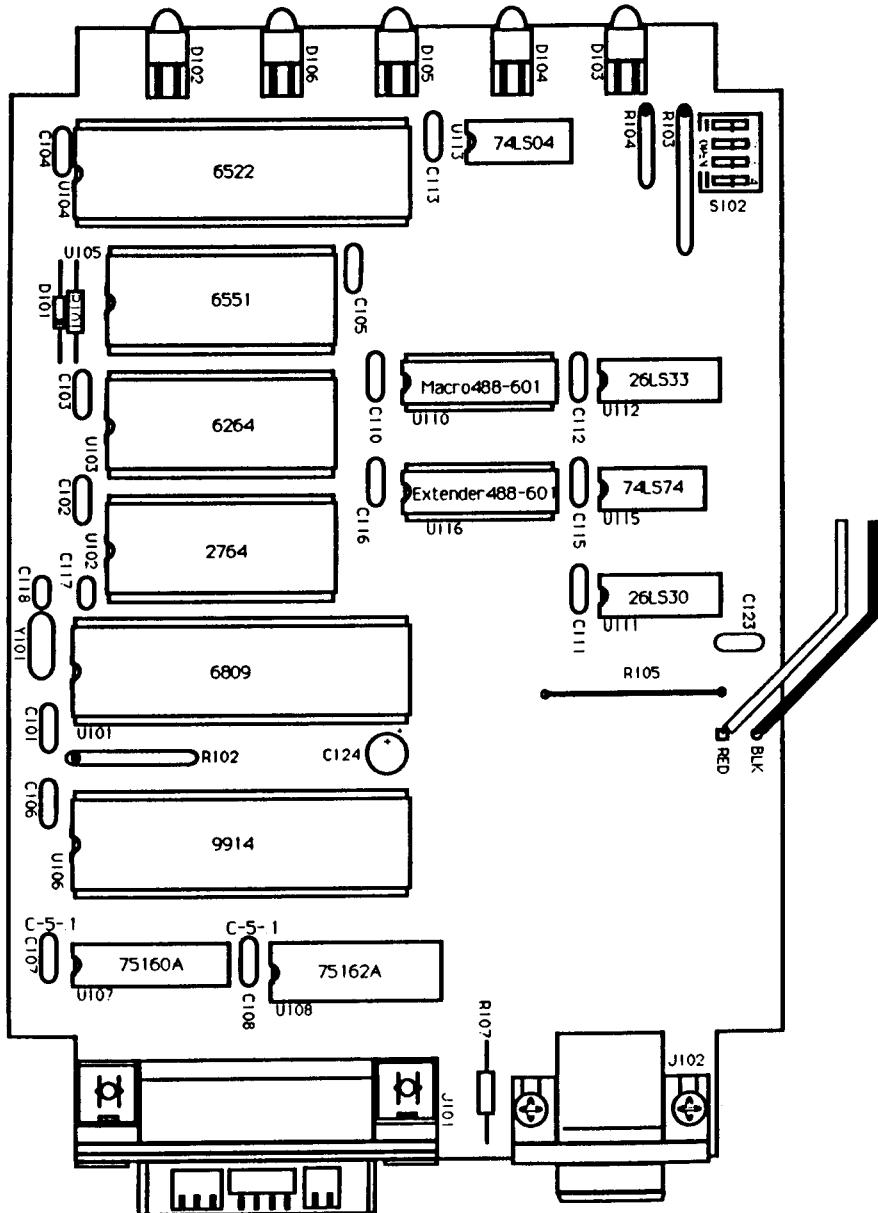

4.4 Extender488/F FIBER OPTIC I/O BOARD COMPONENT LAYOUT

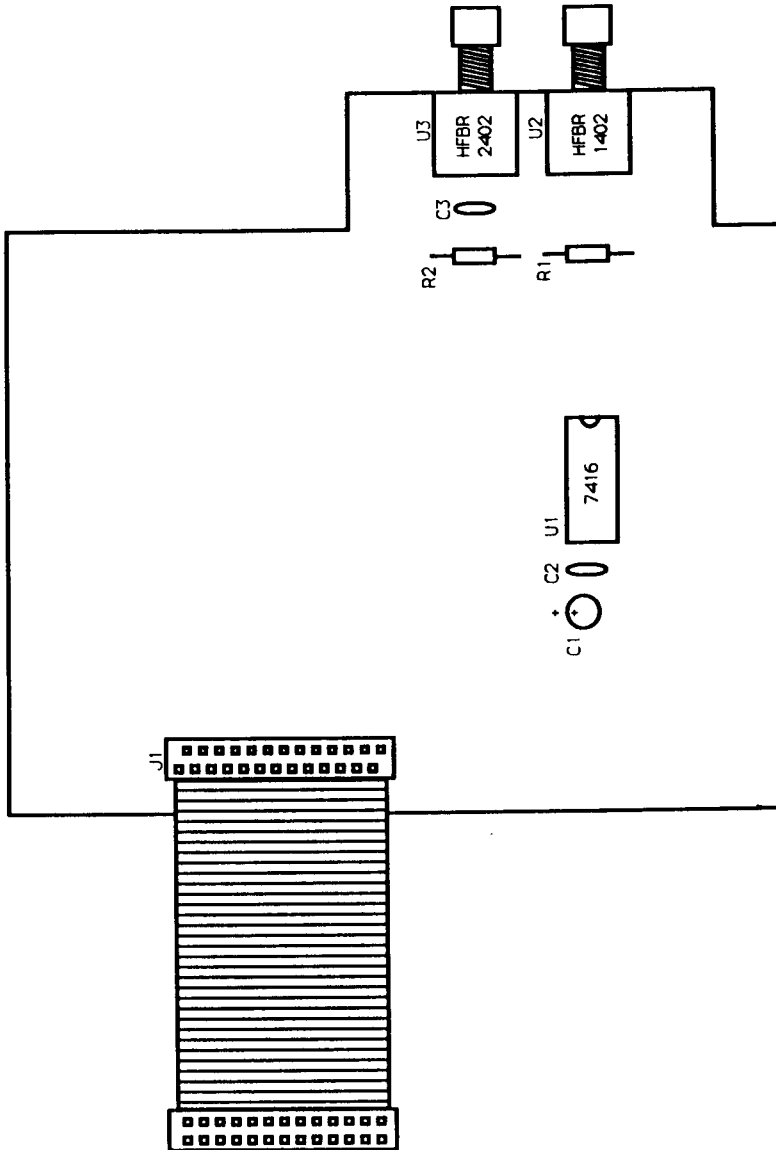

4.5 Extender488 and Extender488/F PARTS LIST

Designation	Part Numbers	Description
C101	C-5-.1	0.1µF Ceramic, 25v
C102	C-5-.1	0.1µF Ceramic, 25v
C103	C-5-.1	0.1µF Ceramic, 25v
C104	C-5-.1	0.1µF Ceramic, 25v
C105	C-5-.1	0.1µF Ceramic, 25v
C106	C-5-.1	0.1µF Ceramic, 25v
C107	C-5-.1	0.1µF Ceramic, 25v
C108	C-5-.1	0.1µF Ceramic, 25v
C110	C-5-.1	0.1µF Ceramic, 25v
C111*	C-5-.1	0.1µF Ceramic, 25v
C112*	C-5-.1	0.1µF Ceramic, 25v
C113	C-5-.1	0.1µF Ceramic, 25v
C115	C-5-.1	0.1µF Ceramic, 25v
C116	C-5-.1	0.1µF Ceramic, 25v
C117	C-5-15p	15pF Ceramic, 25v
C118	C-5-15p	15pF Ceramic, 25v
C123	C-5-1	1µF Ceramic, 25v
C124	C-2-10	10µF Electrolytic, 25v
C201**	C-2-10	10µF Electrolytic, 25v
C202**	C-5-.1	0.1µF Ceramic, 25v
C203**	C-5-.1	0.1µF Ceramic, 25v
D101	RF-1	Small Signal Diode
D102	DD-2	Red PC Mount
D103	DD-2	Red PC Mount
D104	DD-2	Red PC Mount
D105	DD-2	Red PC Mount
D106	DD-2	Red PC Mount
J101	CN-2	IEEE 488 Connector
J102*	CN-7-9	PC Mount Male DB-9
J103	CN-11	9 Volt Power Jack
J104**	CN-5-13	13 x 2 0.1" Header
J201**	CA-6	Cable Assembly

Designation	Part Numbers	Description
U101	IC-1	MC68B09P Microprocessor
U102*	Extender488-600	Programmed EPROM - 2764
U102**	Extender488/F-600	Programmed EPROM - 2764
U103	IC-41	8k x 8 CMOS SRAM
U104	IC-23	65B22 Versatile Interface Adapter
U105	IC-16	R6551AP UART
U106	IC-3	TMS9914ANL IEEE Controller
U107	IC-4	SN75160BN IEEE Driver
U108	IC-5	SN75162BN IEEE Driver
U110	Macro488-601	Programmed 16L8A PAL
U111*	IC-38	26LS30 RS-423 Driver
U112*	IC-36	26LS33 RS-422 Receiver
U113	IC-33	74LS04 Hex Inverter
U115	IC-51	74LS74 Dual D Flip Flop
U116	Extender488-601	Programmed 16L8A PAL
R101	R-1-68K	68K $\frac{1}{2}$, 1/4w carbon
R102	RN-4-4.7K	4.7K $\frac{1}{2}$ x 7 SIP
R103*	RN-1-10K	10K $\frac{1}{2}$ x 9 SIP
R104	RN-2-470	470 $\frac{1}{2}$ x 5 SIP
R107*	R-1-100	100 $\frac{1}{2}$, 1/4w carbon
R201**	R-1-47	47 $\frac{1}{2}$, 1/4w carbon
R202**	R-1-1K	1K $\frac{1}{2}$, 1/4w carbon
S101	SW-8	DPST Rocker - power switch
S102*	SW-6-4	4 Pole DIP
Y101	CR-4	7.3728 MHz Crystal

* Used on Extender488 only

** Used on Extender488/F only

BITS		CONTROL		NUMBERS SYMBOLS		UPPER CASE		LOWER CASE	
B7	B6 B5	0 0 0	0 0 1	0 1 0	0 1 1	1 0 0	1 0 1	1 1 0	1 1 1
B4	B3 B2 B1	0 0 0 0	0 0 0 1	0 0 1 0	0 0 1 1	0 1 0 0	0 1 0 1	0 1 1 0	0 1 1 1
		NUL	DLE	SP	0	@	P	\	p
		SOH	DC1	!	1	A	Q	a	q
		STX	DC2	"	2	B	R	b	r
		ETX	DC3	#	3	C	S	c	s
		EOT	DC4	\$	4	D	T	d	t
		ENQ	NAK	%	5	E	U	e	u
		ACK	SYN	&	6	F	V	f	v
		BEL	ETB	'	7	G	W	g	w
		BS	CAN	(8	H	X	h	x
		HT	EM)	9	I	Y	i	y
		LF	SUB	*	:	J	Z	j	z
		VT	ESC	+	;	K	[k	{
		FF	FS	,	<	L	\	l	!
		CR	GS	-	=	M]	m	}
		SO	RS	.	>	N	^	n	~
		SI	US	/	?	O	_	o	~
		ADDRESSED COMMANDS	UNIVERSAL COMMANDS	LISTEN ADDRESSES	TALK ADDRESSES	SECONDARY ADDRESSES OR COMMANDS			

KEY: octal 25 PPU Message Mnemonic
 NAK ASCII/ISO character
 hex 15 21 decimal

ASCII 7-bit Code Chart