

Overview 1
Hardware Setup 3
Software Setup 3
DBK46 – Specifications4

For use with: **DaqBook/2000A**
DaqBook/2000E
DaqBook/2000X
WBK41



Reference Notes:

- Chapter 2 includes pinouts for P1, P2, P3, and P4. Refer to pinouts applicable to your system, as needed.
- The P3 connector's DAC related pins [31, 32, 33, and 34] apply to the DaqBook/2000 Series Device only when a DBK46 is installed. For WBK41, DAC related connections are made via a front panel screw terminal block.

Overview

The DBK46 is a factory-installed option currently available for DaqBook/2000A, DaqBook/2000E, DaqBook/2000X, and WBK41. JP1 plugs into a 40-pin header on the primary acquisition device. Analog DAC Output is then available, as follows:

- For DaqBook/2000 Series devices, from the device's P3 connector.
- For WBK41, from a front panel terminal block.

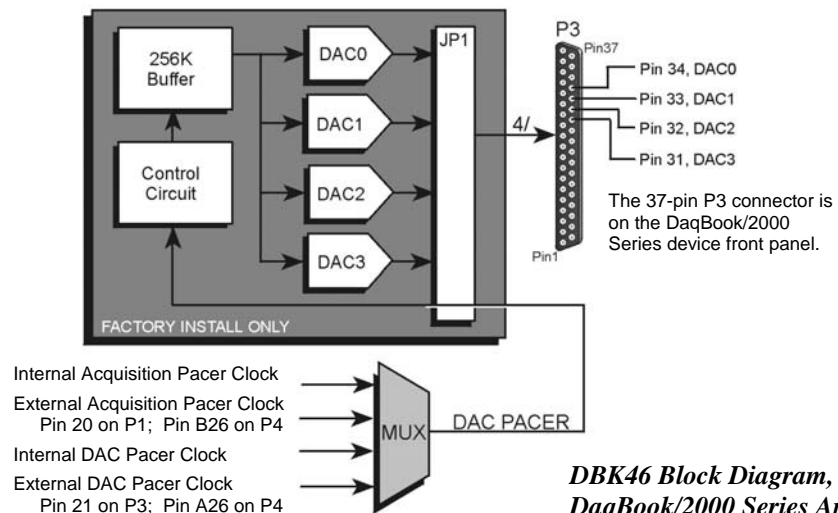

**DBK46 Block Diagram,
DaqBook/2000 Series Applications**

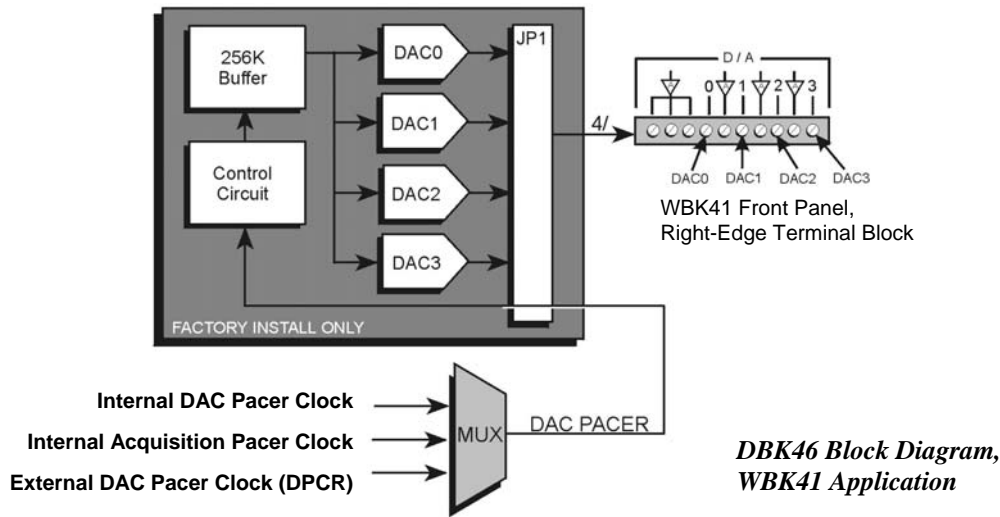

The DBK46 has a 256K sample buffer that can be used for one to four DACs. If only one DAC is enabled for waveform output, then the entire 256K sample memory can be used to store a waveform for that DAC. If two DACs are enabled for waveform output, then 128K of sample memory is available for each of the two DACs. Use of all four DACs drops the available memory down to 64K per DAC.

Software loads the waveform(s) into all, or a portion of, the 256K sample buffer. The waveform data drives the DACs at the rate of the specified DAC Pacer Clock. The waveforms will repeat until the DACs are disabled by software.

The DBK46 provides an output range of -10V to +10V. The card's 256 Kbyte of sample buffer memory can store waveforms from the PC.

When used to generate waveforms for a DaqBook/2000 Series device, each DAC can be independently clocked in one of four modes. These are:

- **Internal DAC Pacer Clock** - The on-board programmable clock can generate updates ranging from 1.5 Hz to 100 kHz, independent of any acquisition rate.
- **Internal Acquisition Pacer Clock** - Using the on-board programmable clock, the analog output *rate of update* can be synchronized to the acquisition rate derived from 100 kHz to once every 5.96 hours.
- **External DAC Pacer Clock** - A user-supplied external input clock can be used to pace the DAC, entirely independent of other analog inputs.
- **External Acquisition Pacer Clock** - A user-supplied external input clock can simultaneously pace the DAC and the analog input.

When used to generate waveforms in a WBK41, the DACs can be clocked in one of three modes. These are:

- **Internal DAC Pacer Clock** - The WBK41 programmable clock can generate updates ranging from 1.5 Hz to 100 kHz, independent of any acquisition rate.
- **Internal Acquisition Pacer Clock** - By using the WBK41 programmable clock, the analog output *rate of update* can be synchronized to the acquisition rate derived from 100 kHz to once every 5.96 hours.
- **External DAC Pacer Clock (DPCR)** - A user-supplied external input clock can be used to pace the DAC, entirely independent of other analog inputs. This external clock input connects to the DPCR connector, located on the Counter/Timer Terminal Block.

Hardware Setup

DBK46 is installed at the factory. To verify that a DBK46 is installed, simply check the acquisition software's Analog Output Window for the presence of DAC0, DAC1, DAC2, and DAC3.

Software Setup

DBK46 does not require setup in software.

Reference Notes:



- **DaqView Users:** In regard to the *out-of-the-box* software and analog output channels, refer to the *DaqView and DaqViewXL* Document Module, especially the following two sections: *Analog Output Window*, and *Waveform and Digital Pattern Output Window*.
- **WaveView Users:** In regard to the *out-of-the-box* software, refer to the *WaveView* Document Module.
- PDF versions of the documents are included on the data acquisition CD and can be accessed via the <View PDFs> button, which is located on the CD's intro-screen.

DBK46 – Specifications

The four analog output channels are updated synchronously relative to scanned inputs, and are clocked from either an internal clock on the primary acquisition device, such as a DaqBook/2000A; or from a user-supplied external clock source. Analog outputs can also be updated asynchronously, independent of any other scanning in the system.

Channels: 4

Resolution: 16 bits

Data Buffer: 256 K sample FIFO

Output Voltage Range: $\pm 10\text{V}$

Output Current: $\pm 10\text{ mA}$

Offset Error: $\pm 0.0045\text{V}$ max

Gain Error: $\pm 0.01\%$

Update Rate: 100 kHz max, 1.5 Hz min (no minimum with external clock)

Settling Time: 10 μsec max to 1 LSB for full-scale step

Digital Feed-thru: a spike of up to 50 mV may occur on the DAC output each time the DAC output is updated

Clock Sources: 4 programmable clock sources:

- The primary acquisition device's *onboard D/A input clock*, independent of the scanning input clock
- The primary acquisition device's *onboard scanning input clock*
- An *external D/A input clock*, independent of an external scanning input clock
- An *external scanning input clock*

Note: Specifications are subject to change without notice.