

Overview 1
Hardware Setup 2
 Card Configuration 2
 Card Connection 2
Software Setup 3
Use of CA-115 Cables and DIN5 Power Connectors 3
DBK2 – Specifications 4



This product is not used for LogBook applications.



Reference Notes:

- Chapter 2 includes pinouts for P1, P2, P3, and P4. Refer to pinouts applicable to your system, as needed.
- In regard to calculating system power requirements, refer to *DBK Basics* located near the front of this manual.

Overview

The DBK2 provides the ability to generate precise, bipolar output voltages. The DBK2 connects to the Daq device P1 port. Like other P1-compatible DBK cards, the DBK2 is addressed using one of 16 base channels. Up to 4 DBK2s can share a single base channel for a maximum of 256 channels. The DBK2 can control an array of external devices including programmable power supplies, proportional actuators, analog indicators, and process controllers.

The DBK2 generates output voltages using a 4-channel 14-bit digital-to-analog converter (DAC). A precision bipolar reference is used onboard to provide accurate and stable output voltages. Each output channel is independently jumper configurable for either ± 5 V or ± 10 V operation. A 14-bit DAC can have values from 0 to 16,383 (a value of 8192 should produce a voltage of 0). Thus in the ± 5 V mode, the voltage out $V_{OUT} = [10 \text{ V} \times (\text{DAC}/16383)] - 5 \text{ V}$.

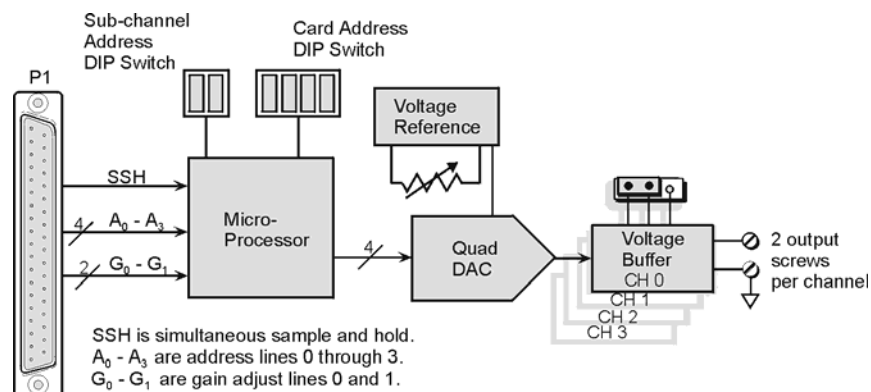

DBK2 Block Diagram

Hardware Setup

Card Configuration

Factory Default: Voltage Range $\pm 5V$

The Daq Device channel and the output level must be configured.

A 6-position DIP switch provides for address selection. The card address refers to the Daq device base channel. Any card address in the range of 0 to 15 is valid. The sub-address allows up to 4 DBK2s to share a single base channel. Any sub-address in the range of 0 to 3 is valid. (With 4 local channels on a card and 4 cards on each of 16 base channels, a maximum of 256 channels are possible.)

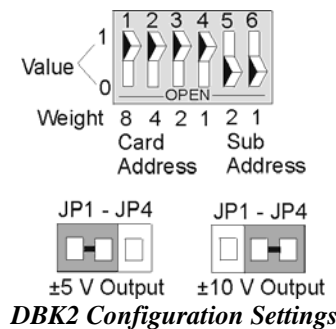

The DIP switch uses binary weighted values. To select the desired address, set the corresponding switch values to one. For example, if the desired card address is 11, switches 1, 3, & 4 should be set to one. To set a switch to a value, depress the corresponding side of the rocker-arm switch.

Each local channel can be set for either $\pm 5V$ or $\pm 10V$ output. Four 3-pin headers (JP1 through JP4) correspond to output channels 0 through 3. To configure a channel for $\pm 5V$ output, place the shunt jumper across positions 1 & 2 (default setting) of the corresponding header (see figure). To configure a channel for $\pm 10V$ output, place the shunt jumper across positions 2 and 3 of the channel header.

Card Connection

Output voltage connections are provided via convenient screw terminals or J1. Each terminal has an adjacent analog common terminal for convenience. After all connections are in place, secure the wires to the card for strain relief. Small nylon tie wraps (not included) work well for this purpose. For convenience, there are also footprints on the board to accommodate BNC connectors.

DaqBook/100 Series & /200 Series and DaqBoard [ISA type] Configuration

Use of the DBK2 requires setting jumpers in DaqBooks/100 Series & /200 Series and DaqBoards [ISA type].

1. If not using auxiliary power, place the DaqBook/100 Series & /200 Series or DaqBoard [ISA-type] JP1 jumper in the expanded analog mode, as indicated for JP1 in the following figure.

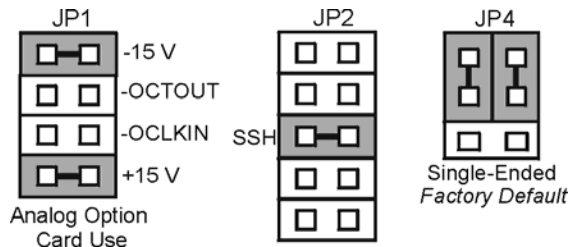

Jumper Configurations On DaqBoard [ISA] and DaqBook/100 Series & /200 Series

Note: JP1, in the previous figure, is indicated in its default position. The default position is necessary to power the interface circuitry of the DBK2 via the internal ± 15 VDC power supply.

CAUTION



If using auxiliary power cards, DBK32A or DBK33, you must remove both JP1 jumpers entirely from JP1.



Reference Notes:

- In regard to calculating system power requirements refer to *DBK Basics* located near the front of this manual.
- Refer to the DBK32A or DBK33 Document Modules if applicable to your application.

CAUTION



When using the SSH output, do not use an external voltage reference for DAC1. Applying an external voltage reference for DAC1, when using the SSH output, will result in equipment damage due to a conflict on P1, pin #26.

2. Place the JP2 jumper in the SSH position.
3. **For DaqBook/100, DaqBook/112 and DaqBook/120 only**, place the JP4 jumper in *single-ended mode*.

DaqBook/2000 Series & DaqBoard/2000 Series

No jumper configurations are required for these 2000 series devices.

Software Setup



Reference Notes:

- **DaqView users** - Refer to Chapter 3, *DBK Setup in DaqView*.
- **LogView users** - Not Applicable.

Use of CA-115 Cables and DIN5 Power Connectors

CA-115 is a 6-inch cable with a male DIN5 connector on both ends. CA-115 is used to connect DBK32As or DBK33s in parallel (when powered by a common power supply).

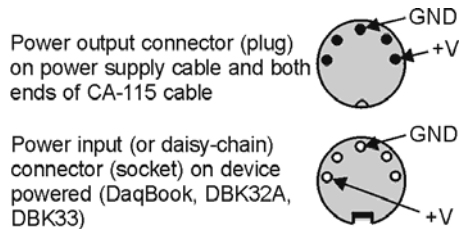

DIN5 Power Connector

DBK2 – Specifications

Name/Function: 4-Channel Voltage Output Card

Connectors: DB37 male, mates with P1. Screw terminals for signal output

Resolution: 14-bits (monotonic)

Output Ranges: ± 5 V or ± 10 V (jumper selectable per channel)

Accuracy: 0.05% of FS

Linearity: 0.02% of FS

Hysteresis: 0.01% of FS