

WEB-TEMP

Web-Enabled Sensor Measurement

User's Guide

Trademark and Copyright Information

Measurement Computing Corporation, InstaCal, Universal Library, and the Measurement Computing logo are either trademarks or registered trademarks of Measurement Computing Corporation. Refer to the Copyrights & Trademarks section on mccdaq.com/legal for more information about Measurement Computing trademarks. Other product and company names mentioned herein are trademarks or trade names of their respective companies.

© 2013 Measurement Computing Corporation. All rights reserved. No part of this publication may be reproduced, stored in a retrieval system, or transmitted, in any form by any means, electronic, mechanical, by photocopying, recording, or otherwise without the prior written permission of Measurement Computing Corporation.

Notice

Measurement Computing Corporation does not authorize any Measurement Computing Corporation product for use in life support systems and/or devices without prior written consent from Measurement Computing Corporation. Life support devices/systems are devices or systems that, a) are intended for surgical implantation into the body, or b) support or sustain life and whose failure to perform can be reasonably expected to result in injury. Measurement Computing Corporation products are not designed with the components required, and are not subject to the testing required to ensure a level of reliability suitable for the treatment and diagnosis of people.

Table of Contents

Preface

About this User's Guide	6
What you will learn from this user's guide	6
Conventions in this user's guide	6
Where to find more information	6

Chapter 1

Introducing the WEB-TEMP	7
Web interface.....	7
TCP/IP connection.....	7
Browser requirement.....	7
WEB-TEMP features.....	7
Temperature channels	7
Alarms	8
Digital I/O channels	8
WEB-TEMP block diagram	8

Chapter 2

Installing the WEB-TEMP	9
What comes with your shipment?.....	9
Hardware	9
Documentation.....	9
Unpacking.....	9
Installing the software	9
Connecting the AC power adapter.....	9
Connecting the WEB-TEMP	10
Connecting to a LAN for communication within a network	10
Connecting to a LAN for communication across networks	10
Connecting the WEB-TEMP directly to a computer.....	11
Using the web interface	12
Logging in to a device.....	13
Configuring the WEB-TEMP using InstaCal	13
Setting network parameters.....	13
Calibrating the Hardware.....	14
Warm-up period.....	14

Chapter 3

Signal Connections.....	15
Screw terminal pinout.....	15
Sensor inputs.....	15
Current excitation outputs.....	16
Four-wire, two sensor common	16
Four-wire, two sensor common	16
CJC sensors.....	16
Digital I/O.....	16
Pull-up/down configuration	16
Analog and digital ground	16
Power output.....	16
Thermocouple connections	17
Wiring configuration.....	17
RTD and thermistor connections	17
Two-wire configuration	18
Three-wire configuration	19
Four-wire configuration.....	19

Semiconductor sensor measurements	20
Wiring configuration.....	20
Digital I/O connections.....	21
Configuring the DIO channels to generate alarms	21
Chapter 4	
Functional Details	22
Thermocouple measurements	22
Cold junction compensation (CJC)	22
Data linearization.....	22
Open-thermocouple detection (OTD)	22
RTD and thermistor measurements	22
Data linearization.....	23
External components	23
Screw terminals.....	23
Ethernet port	23
External power connector	23
POWER/COMM LED	24
LINK/ACTIVITY LED	24
Digital logic voltage switch	24
Factory default reset button.....	24
Chapter 5	
Ethernet Troubleshooting	25
Check the WEB-TEMP status LEDs	25
Check the network settings on the computer	26
Check whether DHCP is enabled on the network server.....	26
Verify that the computer is connected to the network	26
Verify the network path to the WEB-TEMP	27
Verify the network path to a remote WEB-TEMP	28
Check cached information	28
Deleting a NetBIOS table entry	28
Deleting an ARP table	28
Getting help	28
Chapter 6	
Specifications	29
Analog input	29
Channel configurations.....	30
Compatible sensors.....	30
Accuracy.....	31
Thermocouple measurement accuracy	31
Semiconductor sensor measurement accuracy	31
RTD measurement accuracy	32
Thermistor measurement accuracy	32
Throughput rate	33
Digital input/output.....	34
Temperature alarms	34
Memory	34
Microcontroller	35
Power.....	35
Network	35
Ethernet compliance	35
Ethernet connection	35
Network factory default settings	36
Network protocols.....	36

Network security	36
LED displays and the factory reset button	37
Current excitation outputs (Ix+)	37
Environmental	37
Mechanical	37
Screw terminal connector	38
Declaration of Conformity	39

About this User's Guide

What you will learn from this user's guide

This user's guide describes the Measurement Computing WEB-TEMP data acquisition device and lists device specifications.

Conventions in this user's guide

For more information

Text presented in a box signifies additional information related to the subject matter.

Caution! Shaded caution statements present information to help you avoid injuring yourself and others, damaging your hardware, or losing your data.

bold text **Bold** text is used for the names of objects on a screen, such as buttons, text boxes, and check boxes.

italic text *Italic* text is used for the names of manuals and help topic titles, and to emphasize a word or phrase.

Where to find more information

Additional information about WEB-TEMP hardware is available on our website at www.mccdaq.com. You can also contact Measurement Computing Corporation with specific questions.

- Knowledgebase: kb.mccdaq.com
- Phone: 508-946-5100 and follow the instructions for reaching Tech Support
- Fax: 508-946-9500 to the attention of Tech Support
- Email: techsupport@mccdaq.com

Introducing the WEB-TEMP

The WEB-TEMP is a temperature measurement device with a built-in web server. You can connect the device to an Ethernet port or hub, start up your browser, and view current data.

The WEB-TEMP is fully supported by the Universal Library and TracerDAQ. These software programs are included on the *Measurement Computing Data Acquisition Software CD*.

Web interface

The WEB-TEMP embedded web interface provides access to current data and configuration settings using a standard web browser.

Browse to the device home page by entering the URL that is printed on the device into the browser. View current sensor measurements, channel data, and configure hardware options from the device's web pages. Only one user can change configuration options on the device at a time.

The web interface is built into the device's firmware, and does not need to be installed on a computer. No external software is required other than a web browser and a TCP/IP connection.

TCP/IP connection

A TCP/IP connection is required to access the web interface. Connect the device's 10Base-T Ethernet port to a local or wide area network using the supplied Ethernet cable, to a single computer through a hub using the supplied Ethernet cable, or directly to a computer using a standard CAT-5 crossover cable.

Browser requirement

The web browser used to access the WEB-TEMP web interface must support JavaScript. The web interface was tested with the following browsers for compatibility:

- Mozilla Firefox™ 2.x
- Microsoft Internet Explorer® 6.x
- Microsoft Internet Explorer® 7.x

WEB-TEMP features

The WEB-TEMP provides eight temperature channels and eight digital I/O channels. An external supply shipped with the device provides power. On-board LEDs display the status of communication and external power.

All hardware configurable options are selectable with the web browser or InstaCal. Network configurable options are settable with InstaCal. When using InstaCal, if the login settings have been changed from the default, a login name and password are required to change configuration settings.

Temperature channels

The WEB-TEMP provides eight differential input channels that accept temperature sensor type inputs. A 24-bit analog-to-digital (A/D) converter is provided for each pair of analog inputs. Each pair of inputs constitutes a channel pair. Measurements are available from four sensor categories:

- Thermocouple – types J, K, R, S, T, N, E, and B
- Resistance temperature detectors (RTDs) – 2, 3, or 4-wire measurements of 100 Ω platinum RTDs
- Thermistors – 2, 3, or 4-wire measurements
- Semiconductor temperature sensors – LM35, TMP35 or equivalent

The sensor category is software programmable for each channel pair. Each channel pair can connect to a different category of sensor. The sensor category between the channels that constitute a channel pair cannot be mixed. However, thermocouple types within a channel pair can be mixed.

The WEB-TEMP provides four integrated cold junction compensation (CJC) sensors for thermocouple measurements, and built-in current excitation sources for resistive sensor measurements. Each CJC sensor is dedicated to one of the four channel pairs. An open thermocouple detection feature lets you detect a broken thermocouple. An on-board microprocessor automatically linearizes the measurement data according to the sensor category.

Alarms

The WEB-TEMP features eight independent temperature alarms. Each alarm controls an associated digital I/O channel as an alarm output. The input to each alarm is one of the temperature input channels. The output of each alarm is software configurable as active high or low. The user-configurable threshold conditions activate each alarm. When an alarm is activated, the associated DIO channel is driven to the active output state selected.

Digital I/O channels

Eight digital I/O channels are provided to communicate with external devices and to generate alarms. The digital bits are software programmable for input or output. The digital output voltage is switch-selectable for 3.3 V or 5 V logic. A screw terminal is provided for pull-up or pull-down configuration.

The digital I/O channels power up in input mode unless the bit is configured for an alarm. When a digital bit is configured as an alarm, that bit is configured as an output and assumes the state defined by the alarm configuration.

If you need to log data or display data graphically
 The WEB-TEMP displays current data read from the device, and does not log or store historical data. For logging or trending needs, use the TracerDAQ software included on the *Measurement Computing Data Acquisition Software CD*.

WEB-TEMP block diagram

WEB-TEMP functions are illustrated in the block diagram shown here.

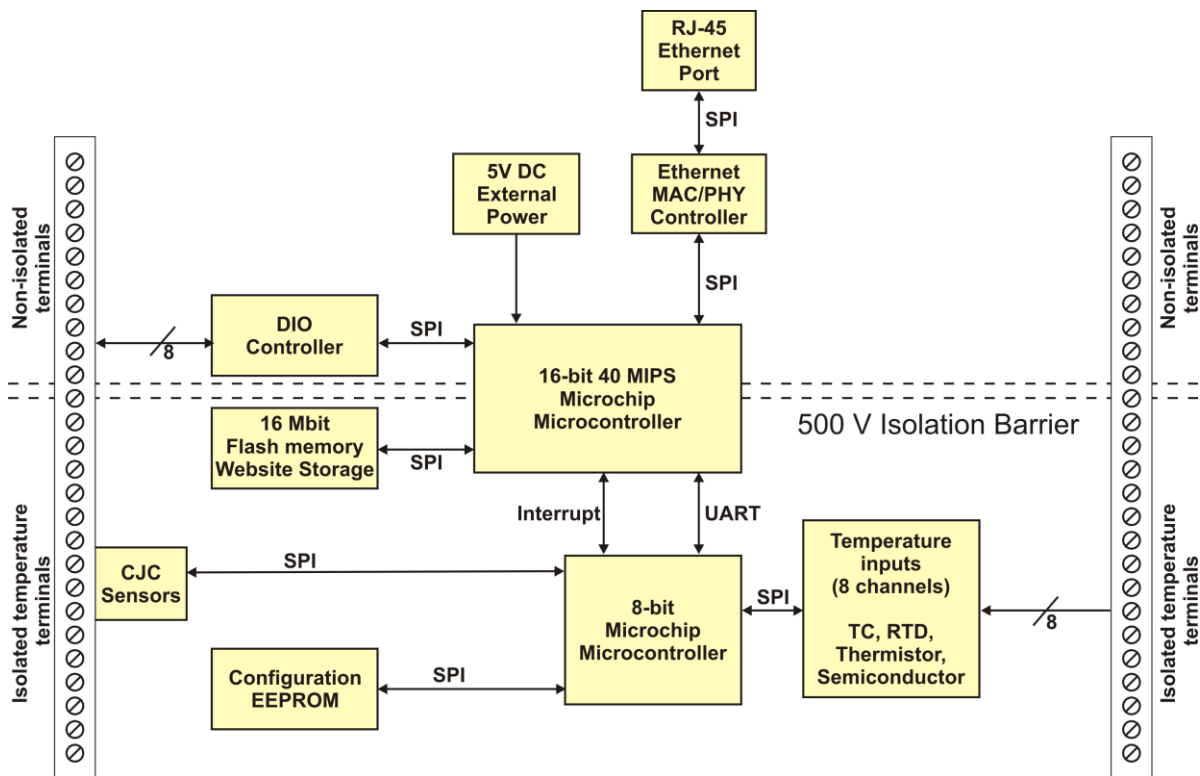

Figure 1. Functional block diagram

Installing the WEB-TEMP

What comes with your shipment?

The following items are shipped with the WEB-TEMP.

Hardware

- WEB-TEMP
- Ethernet cable (standard)
You can optionally purchase a crossover cable (CAT-5 or higher) to connect the WEB-TEMP to an Ethernet card installed in a computer.
- External power supply and cord – 10 watt AC power adapter. MCC part number PS-5V2AEPS.

Software

- MCC DAQ Software CD

Documentation

- Quick Start Guide
This booklet provides an overview of the MCC DAQ software you received with the device, and includes information about installing the software. Please read this booklet completely before installing any software or hardware.
- Setup Options
An overview of installation options is provided in the *WEB-TEMP setup options* that ships with the device.

Unpacking

As with any electronic device, you should take care while handling to avoid damage from static electricity. Before removing the WEB-TEMP from its packaging, ground yourself using a wrist strap or by simply touching the computer chassis or other grounded object to eliminate any stored static charge.

If any components are missing or damaged, contact us immediately using one of the following methods:

- Knowledgebase: kb.mccdaq.com
- Phone: 508-946-5100 and follow the instructions for reaching Tech Support
- Fax: 508-946-9500 to the attention of Tech Support
- Email: techsupport@mccdaq.com

For international customers, contact your local distributor. Refer to the International Distributors section on our website at www.mccdaq.com/International.

Installing the software

Refer to the *Quick Start Guide* for instructions on installing the software on the MCC DAQ CD. This booklet is available in PDF at www.mccdaq.com/PDFmanuals/DAQ-Software-Quick-Start.pdf.

Connecting the AC power adapter

Power to the WEB-TEMP is provided with the 10 watt AC power adapter (PS-5V2AEPS). Connect the adapter cord to the power connector on the WEB-TEMP device, and plug the AC adapter into an electrical outlet.

The **POWER/COMM** LED illuminates when +5 V power is supplied to the WEB-TEMP. If the voltage supply is less than +4.75 V or more than +5.25 V, the **POWER/COMM** LED will not light.

Refer to Figure 11 on page 23 for the location of the **POWER/COMM** LED.

Connecting the WEB-TEMP

A TCP/IP connection between the WEB-TEMP and the network or computer is required to access the web interface. A 10Base-T compatible Ethernet port, hub, or switch is required.

You can connect the WEB-TEMP using the following configurations:

- Connect to your Local Area Network (LAN) for communication within a private network/intranet; refer to the procedure below.
- Connect to your LAN for communication across networks (communicate over the internet, for example); refer to the procedure below.
- Connect directly to a computer's Ethernet port for local access (requires a crossover cable (not provided) or network hub); refer to the procedure on page 11.

Use the standard Ethernet cable provided to connect the WEB-TEMP to a TCP/IP-based local or wide area network or to connect to a single PC through a hub or switch. Use a CAT-5 or higher crossover cable (not provided) to connect the WEB-TEMP to an Ethernet card installed in a computer.

How you access the web interface once a TCP/IP connection is established depends on your configuration:

- When the WEB-TEMP is connected to the same network as the computer browser, enter the URL that is printed on the device to open the device's home page.
- When the WEB-TEMP is connected to a different network as the computer browser, enter the public IP address set for the device to open the device's home page. Refer to "Connecting to a LAN for communication across networks" below for more information.

Connecting to a LAN for communication within a network

Use this procedure to connect the WEB-TEMP to a local area network (LAN). When connected, all computers installed on the same network can access the WEB-TEMP web interface.

Note: This procedure assumes the network server is equipped with DHCP (dynamic host configuration protocol), and will automatically assign an IP address to the WEB-TEMP when it is connected to the network.

1. Connect the WEB-TEMP to the network using the Ethernet cable provided.

The **Link/Activity** LED will illuminate steady green to indicate that you have established a valid Ethernet connection.

2. Open your web browser, and enter the URL that is printed on the device label.

The WEB-TEMP **Measurements** page opens. You can view current measurement data from this page. A log in name (default is "webtemp") and password (default is "mccdaq") are required to change configuration settings.

If the WEB-TEMP is not recognized by the network

If the WEB-TEMP Measurements page does not open, the server may not have DHCP, or DHCP may be disabled on the server. In either situation, assign a static IP address to the WEB-TEMP before connecting to the network. Refer to "Connecting the WEB-TEMP directly to a computer" on page 11 for instructions. After you assign the static IP address, connect to the network using the standard Ethernet cable shipped with the device, open the browser, and enter the static IP address.

Configuring the WEB-TEMP

All hardware options are configurable with InstaCal or the web interface. InstaCal must be used if any of the network parameters need to be changed, such as the IP address of your device. Configuration settings are stored in non-volatile memory in EEPROM, and are loaded on power up.

Refer to the sections "Using the web interface" on page 12 and "Configuring the WEB-TEMP using InstaCal " on page 13 for detailed information.

Connecting to a LAN for communication across networks

In order to communicate with the WEB-TEMP from a computer connected to a different network, such as over the internet, you must change the network configuration of the network router.

In the following procedure, the WEB-TEMP is installed at the "host" LAN, and the computer is installed at the "client" LAN.

Caution! This procedure should only be performed by a network administrator or computer professional. Incorrect settings can significantly disrupt a network.

1. Connect the WEB-TEMP to a LAN (host) that has access to the Internet using the cable provided. The **Link/Activity** LED will illuminate steady green to indicate that you have established a valid Ethernet connection.
2. Configure the WEB-TEMP at the host LAN to access the web page:
 - Assign a fixed "private" static IP address to the WEB-TEMP.
 - Configure the firewall/router to map a static "public" IP address to the "private" IP address assigned above. Record this address for use in step 3.
 - Configure the firewall/router to forward incoming traffic from the public IP address to the HTTP port ("port 80") of the private static IP address.

Note: If your network has an HTTP server already running, network address translation (NAT) allows different ports to redirect to the WEB-TEMP on port 80. Contact your network administrator or computer professional for more information.

Note: To access the WEB-TEMP using InstaCal and the Universal Library, configure the firewall to allow incoming traffic to the UDP port ("port 54211" by default).

3. At the client LAN, open your web browser, and enter the "public" IP address recorded in step 2 above.

Note: To access the WEB-TEMP by name, a DNS entry must be assigned.

The WEB-TEMP **Measurements** page opens. You can view current measurement data from this page. A log in name and password are required to change configuration settings.

Accessing the WEB-TEMP using InstaCal and the Universal Library

InstaCal cannot automatically detect a WEB-TEMP that is installed on a different subnet. To change configuration settings with InstaCal or communicate with a WEB-TEMP using programs written with the Universal Library, manually add the public IP address to InstaCal. InstaCal can then search the public address provided for the WEB-TEMP. We recommend that the port number be set to *54211* for use with InstaCal and the Universal Library. Port 80 is used for the web interface. For information on port configuration, contact your network administrator or computer professional.

Configuring the WEB-TEMP

All hardware options are configurable with InstaCal or the web interface. InstaCal must be used if any of the network parameters need to be changed, such as the IP address of your device. Configuration settings are stored in non-volatile memory in EEPROM, and are loaded on power up.

Refer to the sections "Using the web interface" on page 12 and "Configuring the WEB-TEMP using InstaCal" on page 13 for detailed information.

Connecting the WEB-TEMP directly to a computer

Use this procedure to connect the WEB-TEMP directly to a computer. This scenario provides local access only, and requires that you set up your computer to use a **static IP address** for communication with the WEB-TEMP. If you are not using a network hub, a CAT-5 (or higher) crossover cable is required to connect to the computer's Ethernet port. If you are connecting to your computer through a network hub or switch, the Ethernet cable provided with your device can be used.

Knowledge of network configuration is required

If you are not familiar with network configurations and have questions regarding your network settings, consult your network administrator or a computer professional.

1. Select Start » Control Panel > **Network Connections**.
2. Double-click on **Local Area Connection**.

3. Select **Internet Protocol (TCP/IP)** and click **Properties**.

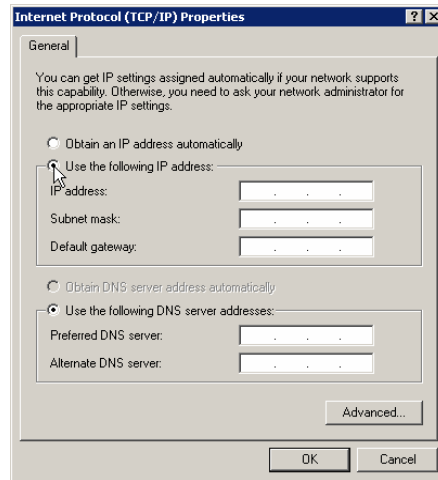

4. Select **Use the following IP address** option and enter the following:
 - o *IP address*: Enter 192.168.0.102. Note that the last three digits of this number can be any number between 11 and 254, inclusive, but must be different from the IP address assigned to the device. The default IP address set for the WEB-TEMP is 192.168.0.101.
 - o *Subnet mask*: Enter 255.255.255.0.
 - o *Default gateway*: Enter 192.168.0.1.

Caution! Assigning an arbitrary IP address could result in duplicate IP addresses on the network. This condition can cause a communication failure that affects both devices. Make sure when configuring static IP addresses that you set different addresses for each device.

5. Click **OK**.
6. Connect the WEB-TEMP Ethernet port to your Ethernet hub using the supplied cable, or to your computer's Ethernet port using a CAT-5 or higher crossover cable.

Note: If you connect to an Ethernet hub, you can use the Ethernet cable shipped with the device. If you have multiple WEB-TEMP devices, configure each device separately and assign a unique IP address to each device. You'll need to run InstaCal to change the IP address from the default 192.168.0.101.

When connected, the **Link/Activity** LED illuminates steady green to indicate that you have established a valid Ethernet connection, and blinks indicating network traffic. Refer to Figure 11 on page 23 for the location of the **Link/Activity** LED.

7. Open your browser and enter the URL address that is printed on the device label.

The WEB-TEMP **Measurements** page opens. You can view current measurement data from this page.

Configuring the WEB-TEMP

All hardware options are configurable with InstaCal or the web interface. InstaCal must be used if any of the network parameters need to be changed, such as the IP address of your device. Configuration settings are stored in non-volatile memory in EEPROM, and are loaded on power up.

Refer to the sections "Using the web interface" below and "Configuring the WEB-TEMP using InstaCal " on page 13 for detailed information.

Using the web interface

You can view current measurements and configure hardware options from the device's web interface. The web interface provides four tabs. Each tab represents an HTML page that is stored on the device.

- **Measurements** tab (home page) – lists the temperature measurements, digital values, and alarm status read from each channel on the WEB-TEMP.

- **System Info** tab – summarizes the current network settings set for the WEB-TEMP, and provides a button that when pressed flashes the **POWER/COMM** LED on the device. Settings on this tab are not configurable via the web interface; use InstaCal to configure network settings.
 - **Configuration** tab – provides separate menu options for configuring your temperature, digital, and alarm options. To change configuration settings, enter the user name (default is "webtemp") and password (default is "mccdaq") set for the device and click the **Log In** button. The user name and password cannot be changed from the web interface – you must use InstaCal to change them.
 - *Temperature* menu option– Use the options on this page to set the sensor category and connection type for each temperature channel pair.

The factory default configuration is *Disabled*. The Disabled mode disconnects the analog inputs from the terminal blocks and internally grounds all of the A/D inputs. This mode also disables each of the current excitation sources. Any channel you don't intend to use should be left disabled.
 - *DIO* menu option – Use the options on this page to set the direction of each digital I/O channel and value of each digital I/O channel configured for Output.
 - *Alarm* menu option – Use the options on this page to set up the temperature conditions to activate an alarm, and the output state of the channel (active high or low) when activated. You can configure up to eight independent alarms.
- The configuration options are enabled on these pages when you are logged in. The device is calibrated to the selected settings each time the "**Submit**" or "**Calibrate**" button is pressed.
- **Help** – summarizes the options on each web page, and includes step-by-step procedures for setting up your temperature channels, digital channels, and alarms.

Logging in to a device

Configurable options are disabled until you log in with the user name and password set for the device. Only one user can be logged in at a time. By default, the user name is set to *webtemp*, and the password is set to *mccdaq*. You can change these values with InstaCal.

Base64 encryption is used to encrypt the login name and password. JavaScript must be enabled on the browser to encrypt login information. If JavaScript is disabled on your browser when you log in, the user name and password values are transmitted as plain text with no encryption applied.

Configuring the WEB-TEMP using InstaCal

All hardware and network options are configurable with InstaCal. When the device is using its default configuration, InstaCal has access to all functions on the device. Login is done in the background if the default user name and password are assigned to the device.

By default, the user name is set to *webtemp*, and the password is set to *mccdaq*. You can change these values with InstaCal. If the user name and password have been changed, configurable options are disabled until you log in with the user name and password set for the device. Only one user can be logged in at a time.

It is recommended that you change the user name and password from the default

To prevent unauthorized changes to your device configuration, make sure you change the user name and password values from the default. In the event that you forget your settings, they can be reset to the default values using the reset button on the device. Pressing and holding the reset button for three seconds sets all network settings back to default including the user name and password.

Note: For security purposes, do not change the log in information to the name and password used to access secure accounts, such as a credit card or bank account.

Setting network parameters

Use InstaCal to change configurable network settings set on the WEB-TEMP. The network parameters are not accessible via the web interface. The device is shipped configured with the following default settings.

Default network settings

Network setting	Default value
Identifier	not set, optional
DHCP setting	Enabled
IP address	192.168.0.101
Subnet mask	255.255.255.000
Gateway	192.168.0.1
Server	Enabled
User name	webtemp
Password	mccdaq
MAC address	00:12:71:Cx:xx:xx, where xxxxx is the device's serial number (read-only)

The following default network parameters are programmable with InstaCal.

- **Identifier:** Text that identifies the WEB Series device. This value is optional, and is not set by default. Up to 48 alpha-numeric characters can be entered.
- **DHCP:** Enables configuration by a DHCP (Dynamic Host Configuration Protocol) Server. DHCP is a service that automatically assigns IP addresses to clients supporting the protocol. If the connected network has a DHCP server, the WEB-TEMP should be assigned an IP address shortly after it is powered up and attached to the network. InstaCal will display the IP address assigned to the WEB-TEMP.
The default DHCP setting for the WEB-TEMP is *Enabled*. Disable this setting when the server is not DHCP-enabled, or when entering a "static" IP address. Unless there is a reason to disable DHCP (such as the network server is not DHCP-enabled), we recommend that you leave DHCP enabled.
- **IP:** The Internet Protocol (IP) address that is stored on the device. Use this address when a DHCP server is not available or when DHCP is disabled.
- **Subnet:** The Subnet Mask that is stored on the device. The Subnet Mask is the part of the IP address that denotes the local Subnet. Use this address when a DHCP server is not available or when DHCP is disabled.
- **Gateway:** The Gateway IP address that is stored on the device. Use this address when a DHCP server is not available or when DHCP is disabled. A gateway is the IP address of the device that bridges subnets within a network.
- **Server:** Enables or disables the device's web page server. Enable this value to view the device's web page with a browser. Disable access to the web page when you want to restrict access to the device to InstaCal or the Universal Library API.
- **User Name and Password:** The user name and password used to log in to a device session. Log in is required only when changing configurable options on the device. Default values can be changed with InstaCal.

A unique 64-bit physical (MAC) address is also assigned to the device. This address is set at the factory and is not user-configurable.

Restoring factory default network settings

To restore network settings to factory default values, press and hold the device's **reset button** for three seconds. If InstaCal is open when default settings are restored, click the **Refresh Boards** button on InstaCal's tool bar to reflect the changes.

Calibrating the Hardware

The WEB-TEMP is calibrated to the selected device settings each time a *Submit* or *Calibrate* button is pressed on a web interface configuration page, or the *OK* button is pressed on an InstaCal board configuration page.

Warm-up period

After you configure the hardware options, allow the WEB-TEMP to warm up for 30 minutes before taking measurements. This warm up time minimizes thermal drift and achieves the specified rated accuracy of measurements. For analog, RTD or thermistor measurements, this warm-up time is also required to stabilize the internal current reference.

Signal Connections

Screw terminal pinout

The WEB-TEMP has four rows of screw terminals. There are 26 connections on each side. Signals are identified in Figure 2.

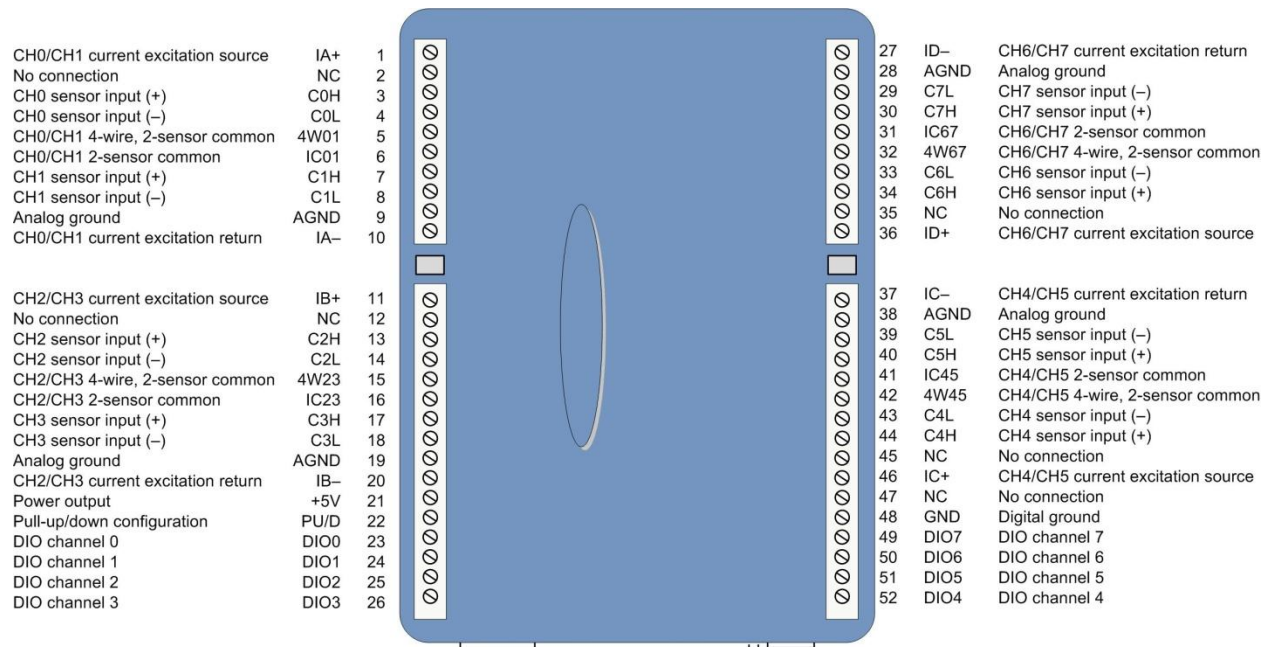

Figure 2. Screw terminal pinout

Do not make connections to the terminals labeled **NC**. Use 16 AWG to 30 AWG wire for your signal connections.

Tighten screw terminal connections

When making connections to the screw terminals, be sure to tighten the screw until tight. Simply touching the top of the screw terminal is not sufficient to make a proper connection.

Sensor inputs

The WEB-TEMP supports the following temperature sensor types:

- Thermocouple – types J, K, R, S, T, N, E, and B
- Resistance temperature detectors (RTDs) – 2, 3, or 4-wire measurement modes of 100 Ω platinum RTDs.
- Thermistors – 2, 3, or 4-wire measurement modes.
- Semiconductor temperature sensors – LM35, TMP35 or equivalent

Sensor selection

The type of sensor you select will depend on your application needs. Review the temperature ranges and accuracies of each sensor type to determine which is best suited for your application.

You can connect up to eight temperature sensors to the differential sensor inputs (**C0H/C0L** to **C7H/C7L**). Supported sensor categories include thermocouples, RTDs, thermistors, or semiconductor sensors.

Do not mix sensor categories within channel pairs. You can, however, mix thermocouple types (J, K, R, S, T, N, E, and B) within channel pairs.

Do not connect two different sensor categories to the same channel pair

The WEB-TEMP provides a 24-bit A/D converter for each channel pair. Each channel pair can monitor one sensor category. To monitor a sensor from a different category, connect the sensor to a different channel pair.

Current excitation outputs

The WEB-TEMP has four dedicated pairs of current excitation output terminals ($\pm IA$ to $\pm ID$). These terminals have a built-in precision current source to provide excitation for the resistive sensors used for RTD and thermistor measurements.

Each current excitation terminal is dedicated to one pair of sensor input channels:

- IA+ is the current excitation source for channel 0 and channel 1
- IB+ is the current excitation source for channel 2 and channel 3
- IC+ is the current excitation source for channel 4 and channel 5
- ID+ is the current excitation source for channel 6 and channel 7

Four-wire, two sensor common

Terminals **4W01**, **4W23**, **4W45**, and **4W67** are the common connection for four-wire configurations with two RTD or thermistor sensors.

Four-wire, two sensor common

Terminals **IC01**, **IC23**, **IC45**, and **IC67** are used as the common connection for four-wire configurations with two RTD or thermistor sensors.

CJC sensors

The WEB-TEMP has four built in high-resolution temperature sensors for thermocouple measurements. Each CJC sensor is dedicated to one of the four channel pairs, and is located behind the associated channel's screw terminal. These sensors measure the ambient temperature at the terminal block so that the cold junction voltage can be calculated.

Digital I/O

You can connect up to eight digital I/O lines to the screw terminals labeled **DIO0** to **DIO7**. Each terminal is software configurable for input or output. A **PU/D** terminal is provided for pull-up/down configuration.

If a digital bit is set up as an alarm, the bit is configured for output and assumes the state defined by the alarm configuration.

Pull-up/down configuration

All digital I/O lines are connected through 47 k Ω to the **PU/D** pin, which is floating by default. For a pull-up configuration, connect the **PU/D** pin to the +5V pin. For a pull-down configuration, connect the **PU/D** pin to the **GND** pin.

Analog and digital ground

The analog ground (**AGND**) terminals provide a common ground for the sensor input channels. AGND pins are isolated from the GND pin and from earth ground. Thermocouple sensors can connect to voltages that are referenced to earth ground, as long as the isolation between the AGND pins and earth ground is maintained.

The ground (**GND**) terminal provides a common ground for the digital I/O channels. The GND pin is isolated from the AGND pins and from earth ground.

Power output

The **+5V** output terminal is isolated (500 VDC) from the analog input terminals.

Caution! The +5V terminal is an output. Do not connect an external power supply to this terminal or you may damage the WEB-TEMP and possibly the computer.

Thermocouple connections

A thermocouple consists of two dissimilar metals that are joined together at one end. When the junction of the metals is heated or cooled, a voltage is produced that correlates to temperature.

The WEB-TEMP makes fully differential thermocouple measurements without requiring ground-referencing resistors. A 32-bit floating point value in either a voltage or temperature format is returned by software. Open thermocouple detection (OTD) is available for each thermocouple input. OTD automatically detects an open or broken thermocouple.

Use the web browser or InstaCal to select the thermocouple type (J, K, R, S, T, N, E, and B) and one or more input channels to connect the thermocouple.

Wiring configuration

Connect the thermocouple to the WEB-TEMP using a differential configuration, as shown in Figure 3.

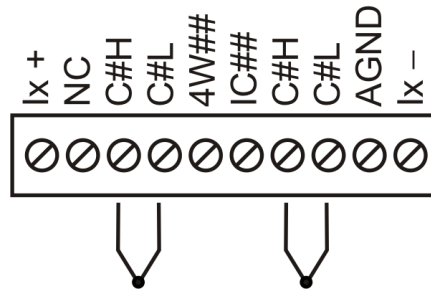

Figure 3. Typical thermocouple connection

Note: There are two high/low channel pairs on each terminal. The # indicates the channel number. Do not make connections to pin marked "NC".

Connect thermocouples to the WEB-TEMP such that they are floating with respect to AGND. The AGND pins are isolated from earth ground, so connecting thermocouple sensors to voltages referenced to earth ground is permissible as long as the isolation between the AGND pins and earth ground is maintained.

When thermocouples are attached to conductive surfaces, the voltage differential between multiple thermocouples must remain within ± 1.4 V. For best results, we recommend the use of insulated or ungrounded thermocouples when possible.

Maximum input voltage between analog input and ground

The absolute maximum input voltage between an analog input and the isolated AGND pins is ± 25 VDC when the WEB-TEMP is powered on, and ± 40 VDC when the WEB-TEMP is powered off.

If you need to increase the length of your thermocouple, use the same type of thermocouple wires to minimize the error introduced by thermal EMFs.

RTD and thermistor connections

A resistance temperature detector (RTD) measures temperature by correlating the resistance of the RTD element with temperature. A thermistor is a thermally-sensitive resistor that is similar to an RTD in that its resistance changes with temperature — thermistors show a large change in resistance that is proportional to a small change in temperature. The main difference between RTD and thermistor measurements is the method used to linearize the sensor data.

RTDs and thermistors are resistive devices that require an excitation current to produce a voltage drop that can be measured differentially across the sensor. The WEB-TEMP features four pairs of current excitation sources ($\pm IA$ to $\pm ID$) for measuring resistive type sensors. Each current excitation terminal is dedicated to one pair of sensor input channels:

- IA+ is the current excitation source for channel 0 and channel 1
- IB+ is the current excitation source for channel 2 and channel 3

- IC+ is the current excitation source for channel 4 and channel 5
- ID+ is the current excitation source for channel 6 and channel 7

The WEB-TEMP makes two, three, and four-wire measurements of RTDs (100 Ω platinum type) and thermistors.

Use InstaCal or the web interface to select the sensor type and the wiring configuration. Once the resistance value is calculated, the value is linearized in order to convert it to a temperature value. A 32-bit floating point value in either temperature or resistance is returned by software.

RTD maximum resistance

Resistance values greater than 660 Ω cannot be measured by the WEB-TEMP in the RTD mode. The 660 Ω resistance limit includes the total resistance across the current excitation ($\pm I_x$) pins, which is the sum of the RTD resistance and the lead resistances.

Thermistor maximum resistance

Resistance values greater than 180 k Ω cannot be measured by the WEB-TEMP in the thermistor mode. The 180 k Ω resistance limit includes the total resistance across the current excitation ($\pm I_x$) pins, which is the sum of the thermistor resistance and the lead resistance.

Two-wire configuration

The easiest way to connect an RTD sensor or thermistor to the WEB-TEMP is with a two-wire configuration, since it requires the fewest connections to the sensor. With this method, the two wires that provide the RTD sensor with its excitation current also measure the voltage across the sensor.

Since RTDs exhibit a low nominal resistance, measurement accuracy can be affected due to the lead wire resistance. For example, connecting lead wires that have a resistance of 1 Ω (0.5 Ω each lead) to a 100 Ω platinum RTD will result in a 1% measurement error.

With a two-wire configuration, you can connect either one sensor per channel pair, or two sensors per channel pair.

Two-wire, single-sensor

A two-wire single-sensor measurement configuration is shown in Figure 4. **Note:** There are two high/low channel pairs on each terminal. The # indicates the channel number. Do not make connections to pin marked "NC".

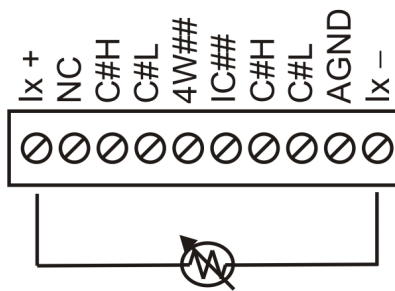

Figure 4. Two-wire, single RTD or thermistor sensor measurement configuration

When you select a two-wire single sensor configuration, connections to C#H and C#L are made internally.

Two-wire, two sensor

A two-wire, two-sensor measurement configuration is shown in Figure 5. **Note:** There are two high/low channel pairs on each terminal. The # indicates the channel number. Do not make connections to pin marked "NC".

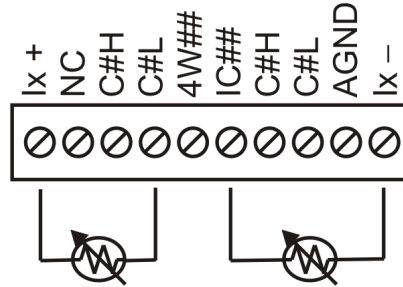

Figure 5. Two-wire, two RTD or thermistor sensors measurement configuration

When you select a two-wire, two sensor configuration, connections to C#H (first sensor) and C#H/C#L (second sensor) are made internally.

When configured for two-wire mode, both sensors must be connected to obtain proper measurements.

Three-wire configuration

A three-wire configuration compensates for lead-wire resistance by using a single voltage sense connection. With a three-wire configuration, you can connect only one sensor per channel pair.

A three-wire measurement configuration is shown in Figure 6. **Note:** There are two high/low channel pairs on each terminal. The # indicates the channel number. Do not make connections to pin marked "NC".

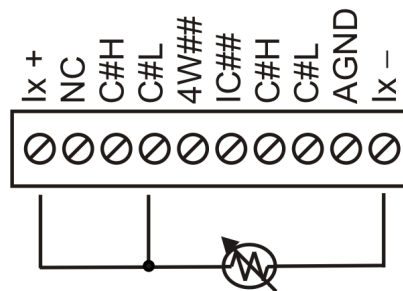

Figure 6. Three-wire RTD or thermistor sensor measurement configuration

When you select a three-wire sensor configuration, the WEB-TEMP measures the lead resistance on the first channel (between Ix+ and C#L) and measures the sensor itself using the second channel (between C#L and Ix-). This configuration compensates for any lead-wire resistance and temperature change in lead-wire resistance. Connections to C#H for the first channel and C#H/C#L of the second channel are made internally.

Three-wire compensation

For accurate three wire compensation, the individual lead resistances connected to the ±I# pins must be of equal resistance value.

Four-wire configuration

With a four-wire configuration, connect two sets of sense/excitation wires at each end of the RTD or thermistor sensor. This configuration completely compensates for any lead-wire resistance and temperature change in lead-wire resistance.

Connect your sensor with a four-wire configuration when your application requires very high accuracy measurements.

Examples of a four-wire single-sensor measurement configuration are shown in Figure 7 and Figure 8. You can configure the WEB-TEMP with either a single sensor per channel or two sensors per channel pair.

Four-wire, single-sensor

A four-wire measurement configuration is shown in Figure 7. The diagram on the left shows the sensor connected to the first channel in the channel pair. The diagram on the right shows the sensor connected to the second channel in the channel pair. The # indicates the channel number. Do not make connections to pin marked "NC".

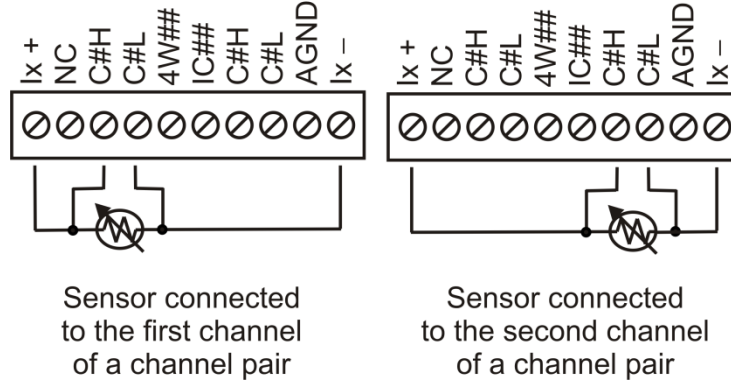

Figure 7. Four-wire, single RTD or thermistor sensor measurement configuration

Four-wire, two-sensor

A four-wire, two-sensor measurement configuration is shown in Figure 8. The # indicates the channel number. Do not make connections to pin marked "NC".

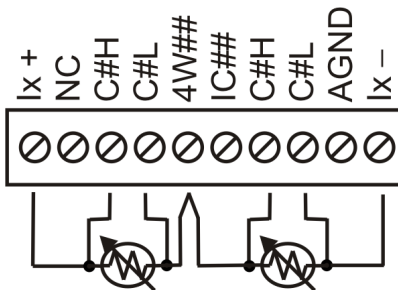

Figure 8. Four-wire, two RTD or thermistor sensors measurement configuration

When configured for four-wire, two sensor mode, both sensors must be connected to obtain proper measurements.

Semiconductor sensor measurements

Semiconductor sensors are suitable over a range of approximately -40 °C to 125 °C, where an accuracy of ±2 °C is adequate. The temperature measurement range of a semiconductor sensor is small when compared to thermocouples and RTDs. However, semiconductor sensors can be accurate, inexpensive and easy to interface with other electronics for display and control.

The WEB-TEMP makes high-resolution measurements of semiconductor sensors and returns a 32-bit floating point value in either a voltage or temperature.

Use InstaCal or the web interface to select the sensor type (LM35, TMP35 or equivalent) and the sensor input channel to connect the sensor.

Wiring configuration

Connect a semiconductor sensor using a single-ended configuration, as shown in Figure 9. The # indicates the channel number. Do not make connections to pins marked "NC". The WEB-TEMP also provides +5V and GND pins for powering the sensor, but use of this power source requires overriding the isolation between analog and power ground by connecting AGND to GND.

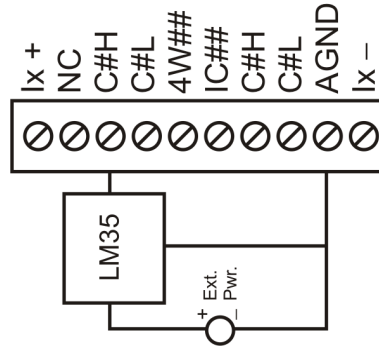

Figure 9. Semiconductor sensor measurement configuration

Digital I/O connections

Connect up to eight digital I/O lines to the screw terminals labeled **DIO0** to **DIO7**. Configure each digital bit for either input or output. All digital I/O lines are connected through 47k to the **PU/D** pin, which is floating by default. For a pull-up configuration, connect the **PU/D** terminal to the +5V terminal. For a pull-down configuration, connect the **PU/D** terminal to the **GND** terminal.

When configuring the digital bits for input, the digital I/O terminals can detect the state of a TTL-compatible device. The ground (**GND**) terminal (pin 48) provides a common ground for the digital I/O channels. Refer to the schematic shown in Figure 10. If the switch is set to the +5V input, DIO0 reads *TRUE* (1). If the switch is moved to GND, DIO0 reads *FALSE* (0).

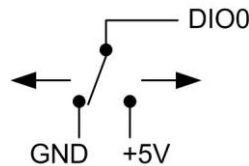

Figure 10. Schematic showing switch detection by digital channel DIO0

When configuring the digital bits, use the switch on the side of the device to set the voltage to either 5 V or 3.3 V (see page 24 for more information). Refer to the digital I/O specification on page 34 for the maximum and minimum threshold levels for each setting.

If a digital bit is set up as an alarm, that bit is configured for output and assumes the state defined by the alarm configuration.

Caution! The ground pin labeled **GND** (pin 48) is isolated from the **AGND** pins and from earth ground. If a connection is made to earth ground and **AGND**, the thermocouples are no longer isolated. In this case, thermocouples must not be connected to any conductive surfaces that may be referenced to earth ground.

For general information regarding digital signal connections and digital I/O techniques, refer to the *Guide to DAQ Signal Connections* (available on our web site at www.mccdaq.com/signals/signals.pdf).

Configuring the DIO channels to generate alarms

The WEB-TEMP features eight independent temperature alarms. All alarm options are configurable using the web browser or InstaCal.

When a digital bit is configured as an alarm, that bit will be configured as an output and assume the state defined by the alarm configuration.

Each alarm controls an associated digital I/O channel as an alarm output. The input to each alarm is one of the temperature input channels. You set up the temperature conditions to activate an alarm, and the output state of the channel (active high or low) when activated. When an alarm is enabled, its associated I/O line is set to output and driven to the appropriate state determined by the alarm options and input temperature. Alarm configuration settings are stored in non-volatile memory and are loaded on power up.

Functional Details

Thermocouple measurements

The WEB-TEMP hardware level-shifts the thermocouple's output voltage into the A/D's common mode input range by applying +2.5 V to the thermocouple's low side at the C#L input. Always connect thermocouple sensors to the WEB-TEMP in a floating fashion. Do not attempt to connect the thermocouple low side C#L to GND or to a ground referencing resistor.

Cold junction compensation (CJC)

When connecting the thermocouple sensor leads to the sensor input channel, the dissimilar metals at the WEB-TEMP terminal blocks produce two additional thermocouple junctions. This junction creates a small voltage error term which must be removed from the overall sensor measurement using a cold junction compensation technique. The measured voltage includes both the thermocouple voltage and the cold junction voltage. To compensate for the additional cold junction voltage, the WEB-TEMP subtracts the *cold junction* voltage from the thermocouple voltage.

The WEB-TEMP has four high-resolution CJC temperature sensors integrated into the design. The CJC sensors are configured as one sensor for each channel pair. CJC sensors measure the average temperature at the terminal block so that the cold junction voltage can be calculated. A software algorithm automatically corrects for the additional thermocouples created at the terminal blocks by subtracting the calculated cold junction voltage from the analog input's thermocouple voltage measurement.

Increasing the thermocouple length

If you need to increase the length of your thermocouple, use the same type of thermocouple wires to minimize the error introduced by thermal EMFs.

Data linearization

After the CJC correction is performed on the measurement data, an on-board microcontroller automatically linearizes the thermocouple measurement data using National Institute of Standards and Technology (NIST) linearization coefficients for the selected thermocouple type. The measurement data is then output as a 32-bit floating point value in the configured format (voltage or temperature).

Open-thermocouple detection (OTD)

The WEB-TEMP is equipped with open-thermocouple detection for each analog input channel. OTD is automatically enabled when the channel pair is configured for thermocouple sensors.

With OTD, any open-circuit or short-circuit condition at the thermocouple sensor is detected by the software. An open channel is detected by driving the input voltage to a negative value outside the range of any thermocouple output. The software recognizes this as an invalid reading and flags the appropriate channel. The firmware continues to sample all channels when OTD is detected.

RTD and thermistor measurements

RTDs and thermistors are resistive devices that require an excitation current to produce a voltage drop that can be measured differentially across the sensor. The WEB-TEMP measures the sensor resistance by forcing a known excitation current through the sensor and then measuring (differentially) the voltage across the sensor to determine its resistance.

After the voltage measurement is made, the resistance of the RTD is calculated using Ohms law – the sensor resistance is calculated by dividing the measured voltage by the current excitation level ($\pm I_x$) source. The value of the $\pm I_x$ source is stored in local memory.

Once the resistance value is calculated, the value is linearized in order to convert it to a temperature value. The measurement is returned by software as a 32-bit floating point value in a resistance or temperature format.

Data linearization

An on-board microcontroller automatically performs linearization on RTD and thermistor measurements.

- RTD measurements are linearized using a Callendar-Van Dusen coefficients algorithm (you select DIN, SAMA, or ITS-90).
- Thermistor measurements are linearized using a Steinhart-Hart linearization algorithm (coefficients provided by the sensor manufacturer's data sheet).

External components

The WEB-TEMP has the following external components, as shown in Figure 11.

- Screw terminals
- Ethernet port
- External power connector
- Status LEDs (POWER/COMM and LINK/ACTIVITY)
- Digital output voltage switch
- Factory default reset button

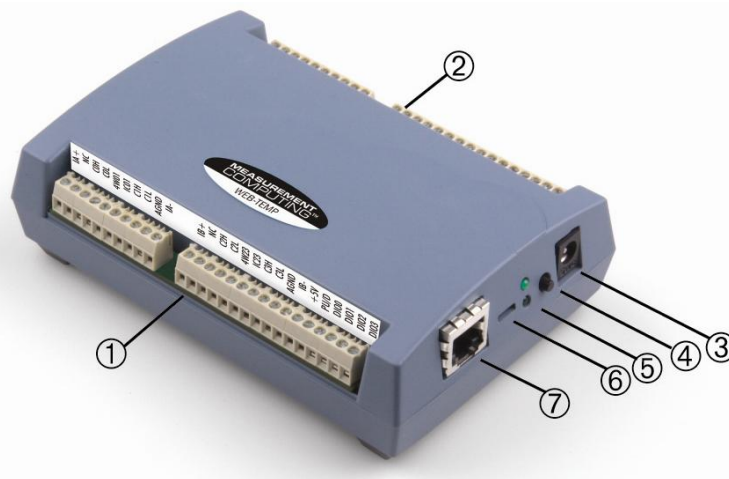

- | | | | |
|---|------------------------------|---|---|
| 1 | Screw terminal pins 1 to 26 | 5 | LEDs: POWER/COMM (top) and LINK/ACTIVITY (bottom) |
| 2 | Screw terminal pins 27 to 52 | 6 | Digital output voltage switch |
| 3 | Power connector | 7 | Ethernet port |
| 4 | Factory default reset button | | |

Figure 11. WEB-TEMP component locations

Screw terminals

The screw terminals provide connections for sensors, digital channels, power, and ground. Detailed information is provided in Chapter 3, [Signal Connections](#), beginning on page 15.

Ethernet port

The WEB-TEMP has one 10BASE-T communication port. The port connector is an eight-position RJ-45 connector. Use the Ethernet cable provided to connect the device to a local or wide area network or to a hub attached to a single computer. Use a CAT-5 (or higher) shielded or unshielded twisted pair crossover cable to connect directly to a computer. The maximum communication distance without using a repeater is 100 meters. Data can transmit up to 100 meters at speeds of up to 100 Mbps using only one crossover Ethernet cable connected to your computer.

External power connector

Use the supplied external power supply (MCC p/n PS-5V2AEPS) to power the WEB-TEMP.

POWER/COMM LED

The **POWER/COMM** LED (upper LED) is on when external power is supplied. The WEB-TEMP has an on-board voltage supervisory circuit that monitors the 5 V external power supply. The table below explains the function of the **POWER/COMM** LED.

LED	Indication
On	4.75 V to 5.25 V external power is supplied to the WEB-TEMP.
Off	Check the following: <ul style="list-style-type: none"> ▪ External power is not supplied; verify that the supply is connected to the external power connector. ▪ A power fault has occurred. A power fault occurs when the input power falls outside of the specified voltage range of the external supply (4.75 V to 5.25 V).

LINK/ACTIVITY LED

The **LINK/ACTIVITY** LED (lower LED) blinks green when a data packet is sent or received over the Ethernet connection. The table below explains the function of the **LINK/ACTIVITY** LED.

LED	Indication
Blinking	Data is being transmitted or received over the Ethernet connection.
On	<ul style="list-style-type: none"> ▪ The Ethernet is idle. ▪ Your network traffic has reached its maximum limit, and no communication is possible. Check with your Network Administrator.
Off	<ul style="list-style-type: none"> ▪ The Ethernet cable is not connected to the WEB-TEMP. ▪ The Ethernet cable is not connected to the network. ▪ The Ethernet cable is damaged. ▪ The Ethernet cable is not the correct type (a crossover cable is required for a direct connection.)

Digital logic voltage switch

The digital logic voltage switch lets you set the voltage to either 3.3 V or 5 V (default setting).

To interface with 3.3 V logic, use the 3.3 V setting. To interface with 5 V logic, use the 5 V setting. Refer to the digital I/O specification on page 34 for the maximum and minimum threshold levels for each setting.



Figure 12. Output voltage switch positions

To change the logic voltage, slide the switch left or right with a screwdriver.

Factory default reset button

Press and hold this button for three seconds to restore the factory default network settings on the WEB-TEMP. When held for 3 seconds, the **POWER** LED will turn off for a short time, indicating a reset is in process. When the **POWER** LED turns back on, reset is complete and the factory default network settings have been restored.

Ethernet Troubleshooting

There are typically only two reasons why you would be unable to communicate with the WEB-TEMP and access the web interface:

- The WEB-TEMP is configured incorrectly, or is operating incorrectly.
- The network is configured incorrectly. Though the WEB-TEMP is functioning normally, you are unable to communicate with it over the network.

Though a detailed treatment of debugging the network is beyond the scope of this manual, there are a few things to try to determine if the problem experienced is a problem with the WEB-TEMP or with the network configuration.

Perform the procedures below to verify the physical and network connections.

Contact your network administrator for issues with your network configuration

Measurement Computing provides technical support for WEB-TEMP connectivity and operation only. For networking issues, contact your network administrator or computer professional.

Check the WEB-TEMP status LEDs

1. Verify the external power connection. When external power is supplied to the WEB-TEMP, the **POWER/COMM** LED illuminates steady green.
 - If the **POWER/COMM** LED is off, check the power cable and the socket that the cable is plugged into. If the cable is good, plugged in, and the power to the socket is on, then the WEB-TEMP is not powering up correctly. Contact MCC technical support. Refer to [Getting help](#) on page 28 for contact information.
2. Verify the Ethernet connection. The **LINK/ACTIVITY** LED illuminates steady green when the WEB-TEMP is connected to an active Ethernet hub or switch.
 - If the **LINK/ACTIVITY** LED is off, verify that the Ethernet cable is the correct type, that it is not damaged, and that it is connected correctly between the WEB-TEMP and a known functional server/hub/switch (or connected to your computer if you are connected directly).
 - If the Ethernet cable is plugged into a wall socket, check with your Network Administrator or computer professional that the wall socket is active, and that it is connected to an active Ethernet hub or switch.

If you are properly connected to an active server/hub/switch and the LED is still off, there is a problem with the WEB-TEMP. Contact MCC technical support. Refer to [Getting help](#) on page 28 for contact information.

3. Verify the network connection:

When the WEB-TEMP is connected to a network, the **LINK/ACTIVITY** LED flashes when there is activity on the network.

- If the **LINK/ACTIVITY** LED is solid green, your network's traffic is at its maximum limit and no communication is possible, or the network traffic is idle. Check with your network administrator.
- If the **LINK/ACTIVITY** LED is not illuminated, there are two possibilities:

You are not connected to the network, even though the WEB-TEMP is connected to an active server/hub/switch. An average network has at least some traffic that causes the LED to blink. Perform the procedure listed in [Checking your TCP/IP settings](#) on page 26.

The WEB-TEMP is not receiving data, and the network connection is verified by a network administrator. Contact MCC technical support. Refer to [Getting help](#) on page 28 for contact information.

When the WEB-TEMP is directly connected to a computer via a crossover cable or a single hub/switch, the **LINK/ACTIVITY** LED flashes when data is transmitted or received over the Ethernet connection.

- If the **LINK/ACTIVITY** LED is not flashing, there are two possibilities:
 - Your computer is not transmitting — verify that your TCP/IP settings are correct, and that you are using a valid IP address for both your computer and WEB-TEMP. Perform the procedure listed in [Check the network settings on the computer TCP/IP settings](#) below.
 - The WEB-TEMP is not receiving — contact MCC technical support. Refer to [Getting help](#) on page 28 for contact information.

Check the network settings on the computer

If the **LINK/ACTIVITY** LED is not flashing, verify that your TCP/IP settings are correct, and that you are using a valid IP address for both your computer and the WEB-TEMP. Use the `ipconfig` utility to return the TCP/IP settings on your computer.

1. Open a DOS Command Prompt window from your computer.
2. Enter `ipconfig` and press the **Return** key. Your computer will display all TCP/IP network configuration values currently set on the computer. An example is shown here.

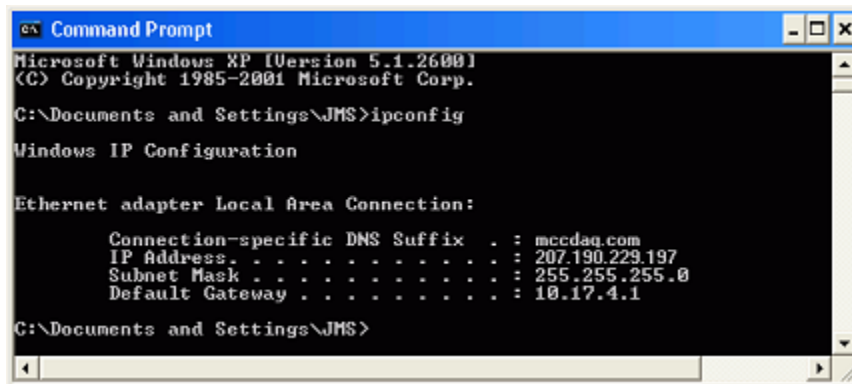

```
ex Command Prompt
Microsoft Windows XP [Version 5.1.2600]
(C) Copyright 1985-2001 Microsoft Corp.

C:\Documents and Settings\JMS>ipconfig

Windows IP Configuration

Ethernet adapter Local Area Connection:

    Connection-specific DNS Suffix  . : mccdaq.com
    IP Address. . . . .               : 207.190.229.197
    Subnet Mask . . . . .             : 255.255.255.0
    Default Gateway . . . . .         : 10.17.4.1

C:\Documents and Settings\JMS>
```

- If the IP Address or Subnet Mask information are all 0's, or if the first three sets (octets) of numbers in either the IP address or Subnet Mask do not match the device's network settings, then the computer will be unable to communicate with the WEB-TEMP. Contact your network administrator or computer professional.

Check whether DHCP is enabled on the network server

You can determine whether DHCP is enabled on the network server — open a DOS Command Prompt and enter `ipconfig /all`. Your computer will display additional TCP/IP information, including the status of DHCP on the network server.

Contact your network administrator regarding network settings

Changes to network configuration should only be performed by your network administrator or computer professional.

Verify that the computer is connected to the network

You can ping (Packet InterNet Groper) the computer to verify that it is connecting to your network. Ping is a diagnostic utility used to send a request to a device. The device then returns a response.

- Enter `ping` followed by the IP address of the computer. Using the address returned in the example above with `ipconfig`, enter `ping 127.0.0.01` and press the **Return** key.

This address tells the computer to test its network setup.

If your computer is connected to the network, a message similar to the one shown here is returned.

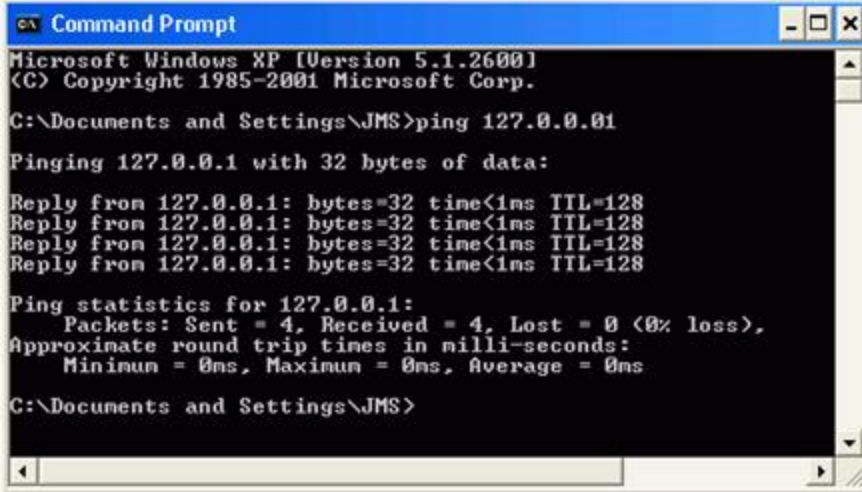

```
ca Command Prompt
Microsoft Windows XP [Version 5.1.2600]
(C) Copyright 1985-2001 Microsoft Corp.

C:\Documents and Settings\JMS>ping 127.0.0.01

Pinging 127.0.0.1 with 32 bytes of data:

Reply from 127.0.0.1: bytes=32 time<1ms TTL=128
Reply from 127.0.0.1: bytes=32 time<1ms TTL=128
Reply from 127.0.0.1: bytes=32 time<1ms TTL=128
Reply from 127.0.0.1: bytes=32 time<1ms TTL=128

Ping statistics for 127.0.0.1:
    Packets: Sent = 4, Received = 4, Lost = 0 (0% loss),
    Approximate round trip times in milli-seconds:
        Minimum = 0ms, Maximum = 0ms, Average = 0ms

C:\Documents and Settings\JMS>
```

If your computer is not connected to the network, a "Request timed out" error or a "Destination host unreachable" message is returned. Check with your network administrator.

Verify the network path to the WEB-TEMP

You can ping the WEB-TEMP to verify that the network path from the computer to the device is set up correctly.

- Enter ping followed by the IP address of the WEB-TEMP.

For example, enter `ping 192.168.0.10` and press the **Return** key. If you can successfully communicate with the WEB-TEMP, a message similar to the one below is returned.

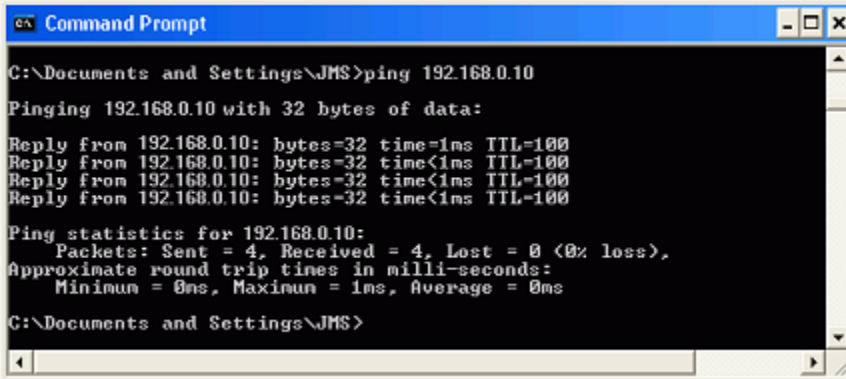

```
ca Command Prompt

C:\Documents and Settings\JMS>ping 192.168.0.10

Pinging 192.168.0.10 with 32 bytes of data:

Reply from 192.168.0.10: bytes=32 time=1ms TTL=100
Reply from 192.168.0.10: bytes=32 time<1ms TTL=100
Reply from 192.168.0.10: bytes=32 time<1ms TTL=100
Reply from 192.168.0.10: bytes=32 time<1ms TTL=100

Ping statistics for 192.168.0.10:
    Packets: Sent = 4, Received = 4, Lost = 0 (0% loss),
    Approximate round trip times in milli-seconds:
        Minimum = 0ms, Maximum = 1ms, Average = 0ms

C:\Documents and Settings\JMS>
```

If a "Request timed out" error or a "Destination host unreachable" message is returned, the network settings may not be set correctly. Press the **RESET** button on the WEB-TEMP to reset the network configuration settings to factory default values. If DHCP is enabled, an IP address is automatically assigned to the device. If DHCP is not enabled, assign the device a unique static IP address and re-establish communication with the WEB-TEMP. Refer to "Connecting the WEB-TEMP directly to a computer" on page 14 for information on how to assign a static IP address.

If the **RESET** button does not restore the network settings, the microcontroller on the WEB-TEMP may not be working. Contact MCC technical support. Refer to [Getting help](#) on page 28 for contact information.

Contact your network administrator regarding network settings

Changes to network configuration should only be performed by your network administrator or computer professional.

Verify the network path to a remote WEB-TEMP

You can ping the network where the WEB-TEMP is installed to verify that the network path from the computer to a device installed on a different network is set up correctly.

- Enter `ping` followed by the public IP address of the network where the WEB-TEMP is installed.
- If a "Request timed out" error or a "Destination host unreachable" message is returned, verify that you have the correct public address for the network where the WEB-TEMP is installed.

If you get a response from the ping of the public network but still cannot communicate with the WEB-TEMP, check the following:

- A unique, fixed "static" IP address has been assigned to the WEB-TEMP.
- The firewall is configured to allow incoming traffic to the HTTP port ("port 80") for access to the web page.
- The firewall is configured to allow incoming traffic to the UDP port ("port 54211" by default) for access through InstaCal and the Universal Library.
- The network at the public IP address is configured to access the fixed address assigned to the WEB-TEMP.

Contact your network administrator regarding firewall settings

Changes to network configuration should only be performed by your network administrator or computer professional.

Check cached information

When your network configuration changes - for example, when you change the static address on one of your devices - you may have obsolete information on PCs that have previously accessed your device. You may be able to update this information simply by disconnecting the network cable from the PC on which the problem exists and reconnecting it. After a short time, the cached information should update. If this doesn't work, the following procedures may help.

Deleting a NetBIOS table entry

If NetBIOS is enabled, "`nbtstat -c`" will provide a list of names and IP addresses. If the `webtc` name is listed, check the associated IP address. If it is different, try typing "`nbtstat -R`" to purge the NetBIOS cache.

Deleting an ARP table

If you suspect that two devices on a network are assigned the same IP address, you can delete the ARP table (Address Resolution Protocol). Do the following:

1. Open a Command Prompt (DOS) window.
2. Enter `arp -d` followed by the address found in step 2 (192.168.0.102 for example) and press **Enter**.

The ARP table will update with the current IP addresses assigned to devices on the network.

Getting help

If you are unable to communicate with the WEB-TEMP, first contact your network administrator or computer professional to verify that you are using the correct TCP/IP network settings, and that your network configuration is working.

If the network configuration and settings are properly set but you still cannot communicate with the WEB-TEMP, the problem may be with the WEB-TEMP. For hardware related issues, contact Measurement Computing Corporation technical support by phone, fax, or email.

- Phone: 508-946-5100 and follow the instructions for reaching Tech Support
- Fax: 508-946-9500 to the attention of Tech Support
- Email: techsupport@mccdaq.com

For international customers, contact your local distributor where you purchased the WEB-TEMP. Click on this link www.measurementcomputing.com/sales.asp to locate your distributor.

Specifications

All specifications are subject to change without notice.

Typical for 25 °C unless otherwise specified.

Specifications in *italic text* are guaranteed by design.

Analog input

Table 1. Generic analog input specifications

Parameter	Condition	Specification
A/D converters		Four dual 24-bit, Sigma-Delta type
Number of channels		8 differential
<i>Input isolation</i>		<i>500 VDC minimum between field wiring and power supply input.</i>
Channel configuration		Software programmable to match sensor type
Differential input voltage range	Thermocouple	±0.080 V
	RTD	0 V to 0.5 V
	Thermistor	0 V to 2 V
	Semiconductor sensor	0 V to 2.5 V
<i>Absolute maximum input voltage</i>	<i>±C0x through ±C7x relative to AGND</i>	<i>±25 V (power on) ±40 V (power off)</i>
<i>Input impedance</i>		<i>5 GΩ (power on) 1 MΩ (power off)</i>
<i>Input leakage current</i>	<i>Open thermocouple detect disabled</i>	<i>30 nA max</i>
	<i>Open thermocouple detect enabled</i>	<i>105 nA max</i>
<i>Common mode rejection ratio</i>	<i>f_{IN} = 60 Hz</i>	<i>100 dB min</i>
ADC resolution		24 bits
<i>ADC No missing codes</i>		<i>24 bits</i>
Input coupling		DC
Warm-up time		30 minutes min
Open thermocouple detect		Automatically enabled when the channel pair is configured for thermocouple sensor. The maximum open detection time is 3 seconds.
<i>CJC sensor accuracy</i>	<i>15 °C to 35 °C</i>	<i>−0.75 °C to 0.5 °C max</i>
	<i>0 °C to 55 °C</i>	<i>−1.5 °C to 1.25 °C max</i>

Channel configurations

Table 2. Channel configuration specifications

Sensor Category	Condition	Max number of sensors (all channels configured alike)
Disabled	All temperature input channels are disconnected from screw terminals and internally connected to AGND.	See Note 3
Thermocouple (Note 1)		8 differential channels
Semiconductor sensor (Note 1)		8 differential channels
RTD and Thermistor (Note 1)	2-wire input configuration with a single sensor per channel pair	4 differential channels
	2-wire input configuration with two sensors per channel pair	8 differential channels
	3-wire configuration with a single sensor per channel pair	4 differential channels
	4-wire input configuration with a single sensor per channel pair	4 differential channels
	4-wire input configuration with two sensors per channel pair	8 differential channels

Note 1: Internally, the WEB-TEMP has four, dual-channel, fully differential A/Ds providing a total of eight differential channels. The analog input channels are therefore configured in four channel pairs with CH0/CH1 sensor inputs, CH2/CH3 sensor inputs, CH4/CH5 sensor inputs, and CH6/CH7 sensor inputs paired together. This "channel-pairing" requires the analog input channel pairs be configured to monitor the same category of temperature sensor. Mixing different sensor types of the same category is permissible, such as a type J thermocouple on channel 0 and a type T thermocouple on channel 1.

Note 2: Channel configuration information is stored on a EEPROM external to the isolated microcontroller by the firmware whenever any item is modified. Modification is performed by commands issued over Ethernet from an external application, and the configuration is made non-volatile through the use of the EEPROM.

Note 3: The factory default configuration is *Disabled*. The Disabled mode disconnects the analog inputs from the terminal blocks and internally grounds (AGND) all of the A/D inputs. This mode also disables each of the current excitation sources.

Compatible sensors

Table 3. Compatible sensor type specifications

Parameter	Specification
Thermocouple	J: -210 °C to 1200 °C
	K: -270 °C to 1372 °C
	R: -50 °C to 1768 °C
	S: -50 °C to 1768 °C
	T: -270 °C to 400 °C
	N: -270 °C to 1300 °C
	E: -270 °C to 1000 °C
B: 0 °C to 1820 °C	
RTD	100 Ω PT (DIN 43760: 0.00385 ohms/ohm/°C)
	100 Ω PT (SAMA: 0.003911 ohms/ohm/°C)
	100 Ω PT (ITS-90/IEC751:0.0038505 ohms/ohm/°C)
Thermistor	Standard 2,252 Ω through 30,000 Ω
Semiconductor / IC	LM35, TMP35 or equivalent

Accuracy

Thermocouple measurement accuracy

Table 4. Thermocouple accuracy specifications, including CJC measurement error. All specifications are (\pm).

Sensor Type	Sensor temperature (°C)	Accuracy error maximum (°C)	Accuracy error typical (°C)	Tempco (°C/°C)
J	-210	3.098	1.762	0.040
	0	1.282	0.724	
	1200	1.178	0.684	
K	-210	3.318	1.843	0.045
	0	1.292	0.730	
	1372	1.495	0.799	
S	-50	1.892	1.058	0.027
	250	0.853	0.479	
	1768	0.734	0.416	
R	-50	2.010	1.124	0.025
	250	0.844	0.475	
	1768	0.612	0.347	
B	250	2.199	2.192	0.004
	700	0.824	0.821	
	1820	0.471	0.469	
E	-200	3.050	1.708	0.038
	0	1.465	0.826	
	1000	1.010	0.564	
T	-200	3.226	1.797	0.045
	0	1.334	0.754	
	400	0.856	0.496	
N	-200	3.406	1.897	0.035
	0	1.300	0.735	
	1300	0.978	0.571	

Note 4: Thermocouple measurement accuracy specifications include polynomial linearization, cold-junction compensation and system noise. These specs are for one year, or 3000 operating hours, whichever comes first, and for operation of the WEB-TEMP between 15 °C and 35 °C after 30 minute warm-up. The tempco should be applied to the accuracy specifications for operation at an ambient temperature outside of the 15 °C and 35 °C range. There are total of four CJC sensors, two per side of the module. Each CJC sensor is dedicated to one of the four channel pairs. The accuracy listed above assumes the screw terminals are at the same temperature as the CJC sensor. Errors shown do not include inherent thermocouple error. Contact your thermocouple supplier for details on the actual thermocouple accuracy error.

Note 5: Thermocouples must be connected to the WEB-TEMP such that they are floating with respect to AGND. The AGND pins are isolated from earth ground. You can connect thermocouple sensors to voltages referenced to earth ground as long as the isolation between the AGND pins and earth ground is maintained.

Note 6: When thermocouples are attached to conductive surfaces, the voltage differential between multiple thermocouples must remain within ± 1.4 V. For best results, we recommend using insulated or ungrounded thermocouples when possible.

Semiconductor sensor measurement accuracy

Table 5. Semiconductor sensor accuracy specifications

Sensor Type	Temperature Range (°C)	Maximum Accuracy Error (°C)
LM35, TMP35 or equivalent	-40 to 150	± 0.50

Note 7: Error shown does not include errors of the sensor itself. These specs are for one year while operation of the WEB-TEMP unit is between 15 °C and 35 °C. Contact your sensor supplier for details on the actual sensor error limitations.

RTD measurement accuracy

Table 6. RTD measurement accuracy specifications

RTD	Sensor temperature (°C)	Accuracy error (°C) maximum	Accuracy error (°C) typical	Tempco (°C/°C)
PT100, DIN, US or ITS-90	-200	2.913	2.784	0.001
	-150	1.201	1.070	0.001
	-100	0.482	0.349	0.001
	0	0.261	0.124	0.001
	100	0.269	0.127	0.001
	300	0.287	0.136	0.001
	600	0.318	0.150	0.001

Note 8: Error shown does not include errors of the sensor itself. The sensor linearization is performed using a Callendar-Van Dusen linearization algorithm. These specs are for one year while operation of the device is between 15 °C and 35 °C. The accuracy and tempco specifications *include* the accuracy of the Callendar-Van Dusen linearization algorithm. The specification does not include lead resistance errors for 2-wire RTD connections. Contact your sensor supplier for details on the actual sensor error limitations.

Note 9: Resistance values greater than 660 Ω cannot be measured by the WEB-TEMP in the RTD mode. The 660 Ω resistance limit includes the total resistance across the current excitation ($\pm I_x$) pins, which is the sum of the RTD resistance and the lead resistances.

Note 10: For accurate three wire compensation, the individual lead resistances connected to the $\pm I_x$ pins must be of equal ohmic value. To ensure this, use connection leads of equal lengths.

Thermistor measurement accuracy

Table 7. Thermistor measurement accuracy specifications

Thermistor	Sensor temperature (°C)	Accuracy error maximum (°C)	Accuracy error typical (°C)	Tempco (°C/°C)
2252 Ω	-40	0.001	0.0007	0.001
	0	0.021	0.008	0.001
	50	0.263	0.130	0.001
	120	3.473	1.750	0.001
5000 Ω	-35	0.001	0.0006	0.001
	0	0.009	0.004	0.001
	50	0.115	0.049	0.001
	120	1.535	0.658	0.001
10000 Ω	-25	0.001	0.0005	0.001
	0	0.005	0.002	0.001
	50	0.060	0.028	0.001
	120	0.771	0.328	0.001
30000 Ω	-10	0.001	0.0005	0.001
	0	0.002	0.001	0.001
	50	0.019	0.009	0.001
	120	0.267	0.128	0.001

Note 11: Error shown does not include errors of the sensor itself. The sensor linearization is performed using a Steinhart-Hart linearization algorithm. The accuracy and tempco specifications *include* the accuracy of the Callendar-Van Dusen linearization algorithm. These specifications are for one year while operation of the device is between 15 °C and 35 °C. The specification does not include lead resistance errors for 2-wire thermistor connections. Contact your sensor supplier for details on the actual sensor error limitations. Total thermistor resistance on any given channel pair must not exceed 180 kΩ. Typical resistance values at various temperatures for supported thermistors are shown in Table 8.

Table 8. Typical thermistor resistance specifications

Temp (°C)	2252 Ω thermistor	3000 Ω thermistor	5 kΩ thermistor	10 kΩ thermistor	30 kΩ thermistor
-40	76 kΩ	101 kΩ	168 kΩ	240 kΩ (Note 12)	885 kΩ (Note 12)
-35	55 kΩ	73 kΩ	121 kΩ	179 kΩ	649 kΩ (Note 12)
-30	40 kΩ	53 kΩ	88 kΩ	135 kΩ	481 kΩ (Note 12)
-25	29 kΩ	39 kΩ	65 kΩ	103 kΩ	360 kΩ (Note 12)
-20	22 kΩ	29 kΩ	49 kΩ	79 kΩ	271 kΩ (Note 12)
-15	16 kΩ	22 kΩ	36 kΩ	61 kΩ	206 kΩ (Note 12)
-10	12 kΩ	17 kΩ	28 kΩ	48 kΩ	158 kΩ
-5	9.5 kΩ	13 kΩ	21 kΩ	37 kΩ	122 kΩ
0	7.4 kΩ	9.8 kΩ	16 kΩ	29 kΩ	95 kΩ

Note 12: Resistance values greater than 180 kΩ cannot be measured by the WEB-TEMP in the thermistor mode. The 180 kΩ resistance limit includes the total resistance across the current excitation ($\pm I_x$) pins, which is the sum of the thermistor resistance and the lead resistances.

Note 13: For accurate three wire compensation, the individual lead resistances connected to the $\pm I_x$ pins must be of equal ohmic value. To ensure this, use connection leads of equal lengths.

Throughput rate

Table 9. Throughput rate specifications

Number of input channels	Maximum throughput
1	2 S/s
2	2 S/s on each channel, 4 S/s total
3	2 S/s on each channel, 6 S/s total
4	2 S/s on each channel, 8 S/s total
5	2 S/s on each channel, 10 S/s total
6	2 S/s on each channel, 12 S/s total
7	2 S/s on each channel, 14 S/s total
8	2 S/s on each channel, 16 S/s total

Note 14: The analog inputs are configured to run continuously. Each channel is sampled twice per second. The maximum latency between when a sample is acquired and the temperature data is provided by the Ethernet unit is approximately 0.5 seconds.

Digital input/output

Table 10. Digital input/output specifications

Parameter	Specification
Digital type	CMOS
Number of I/O	8 (DIO0 through DIO7)
Configuration	Independently configured for input or output. Switch selectable output voltages: +5 V and +3.3 V
Power on conditions	Power on reset is Input mode except when bits are configured to operate as alarms.
Pull-up/pull-down configuration	All pins are connected to 47 k Ω resistors that share a common point accessible at Pin 22 of the device (PU/D). This pin is floating by default and is user-configurable via external connection. For pull-up mode, connect this pin to pin 21 (+5V). For pull-down mode, connect this pin to Pin 48 (GND).
Digital I/O transfer rate (software paced)	<ul style="list-style-type: none"> ▪ Digital input: 50 port reads or single bit reads per second, typ. ▪ Digital output: 100 port writes or single bit writes per second, typ.
Input high voltage (+5 V mode)	4 V min, 5.5 V absolute max
Input high voltage (+3.3 V mode)	2.64 V min, 5.5 V absolute max
Input low voltage (+5 V mode)	1 V max, -0.3 V absolute min
Input low voltage (+3.3 V mode)	0.66 V max, -0.3 V absolute min
Output low voltage (IOL = 2.5 mA)	0.6 V max
Output high voltage (IOH = -2.5 mA)	4.3 V min (+5 V mode), 2.7 V (+3.3 V mode)

Note 15: Ground pins on the device labeled GND are isolated from AGND pins and from earth ground.

Temperature alarms

Table 11. Temperature alarm specifications

Parameter	Specification
Number of alarms	8 (one per digital I/O line)
Alarm functionality	Each alarm controls its associated digital I/O line as an alarm output. The input to each alarm may be any of the analog temperature input channels. When an alarm is enabled, its associated I/O line is set to output and driven to the appropriate state determined by the alarm options and input temperature. The alarm configurations are stored in non-volatile memory and are loaded at power on.
Alarm input modes	<ul style="list-style-type: none"> ▪ Alarm when input temperature > T1 ▪ Alarm when input temperature > T1, reset alarm when input temperature goes below T2 ▪ Alarm when input temperature < T1 ▪ Alarm when input temperature < T1, reset alarm when input temperature goes above T2 ▪ Alarm when input temperature is < T1 or > T2 T1 and T2 may be independently set for each alarm.
Alarm output modes	<ul style="list-style-type: none"> ▪ Disabled, digital I/O line may be used for normal operation ▪ Enabled, active high output. The DIO line goes high when an alarm condition is met. ▪ Enabled, active low output. The DIO line goes low when an alarm condition is met.
Alarm update rate	1 second

Memory

Table 12. Memory specifications

Parameter	Specification
EEPROM	512 bytes for sensor configuration
FLASH	2 MB for device configuration and website storage

Microcontroller

Table 13. Microcontroller specifications

Parameter	Specification
Type	One high-performance 8-bit RISC microcontroller (isolated) One high-performance 16-bit RISC microcontroller (non-isolated)

Power

Table 14. Power specifications

Parameter	Condition	Specification
Supply current (Note 17)	Continuous mode	440 mA max
External power input (Note 16)		+5 VDC \pm 5% (+5 VDC power supply provided)
External power supply (included)	MCC p/n PS-5V2AEPS	+5VDC, 10 W, 5% regulation
Voltage supervisor limits	$4.75 \text{ V} > V_{\text{ext}}$ or $V_{\text{ext}} > 5.25 \text{ V}$	PWR LED = Off (power fault)
	$4.75 \text{ V} < V_{\text{ext}} < 5.25 \text{ V}$	PWR LED = On
User output voltage range	Available at +5V screw terminal	4.65 V min, 5.25 V max
User output current available	Available at +5V screw terminal	10 mA max

Note 16: Voltage specification applies at barrel plug power input. The power supply provided with the board meets this specification at the rated total power supply current. If a different power supply is used, small line resistances could cause significant voltage drop between the power supply and the barrel plug input.

Note 17: This is the total current requirement for the WEB-TEMP which includes up to 20 mA for the LEDs and 10 mA for the user voltage output.

Network

Ethernet compliance

Table 15. Ethernet compliance specifications

Parameter	Specification
Device type	IEEE 802.3 Ethernet 10Base-T
Device compatibility	IEEE 802.3-2003 10 Mbps Media Access Control

Ethernet connection

Table 16. Ethernet connection specifications

Parameter	Specification
Ethernet type	10Base-T
Connector	RJ-45, 8 position
Cable	CAT-5 shielded, unshielded twisted pair
Length	100 meters max
MAC address	00:12:71:Cx:xx:xx, where xxxxx is the device serial number

Network factory default settings

Table 17. Factory default specifications

Parameter	Specification
Factory default IP address	192.168.0.101
Factory default subnet mask	255.255.255.0
Factory default Gateway	192.168.0.1
Factory default DHCP setting	Enabled
Factory default user name	"webtemp"
Factory default password	"mccdaq"
Web server	Enabled

Network protocols

Table 18. Factory default specifications

Parameter	Specification
Protocols implemented	IP, ARP, ICMP, DHCP, UDP, TCP, NBNS, HTTP Protocols using UDP or TCP for transport communicate on their IETF assigned ports, for example HTTP on TCP port 80.
UDP messaging protocol	UDP port 54211
TCP downloading protocol	TCP port 54267
HTTP 1.0 alternate port	TCP port 49152-65535 (not including 54267)
Network name	"webtemp_XXXX", where XXXX is the device serial number
Network name publication	Via NBNS (responds to b-node broadcasts, therefore only available on the local subnet)
Max number of simultaneous HTTP connections	3
Max number of non-HTTP TCP sockets	5

Network security

Table 19. Factory default specifications

Parameter	Specification
Security implementation	IP address based session manager with user-name/password login for configuration and control transactions (data is not secured.)
Session timeout	5 minutes with no activity
User-name/password encryption	Base64 The default web page does not support encryption if Javascript is disabled in the web browser.
Vulnerabilities	Denial of service attacks, user-name/password spoofing, script probing and simple decryption

LED displays and the factory reset button

Table 20. LED and button configurations

Parameter	Specification
POWER/COMM LED (top)	$4.75\text{ V} < V_{\text{ext}} < 5.25\text{ V}$ On $V_{\text{ext}} < 4.75\text{ V}, V_{\text{ext}} > 5.25\text{ V}$ Off (power fault) Blinks during microcontroller communications.
LINK/ACTIVITY LED (bottom)	On when a valid Ethernet connection is established. Blinks when an Ethernet packet is sent or received.
Factory reset button	Press for 3 seconds to restore the factory default network settings. When pressed for 3 seconds, the POWER LED turns off for a short time, indicating that a reset is in process. When the POWER LED turns back on, the reset is complete and the factory default network settings are restored.

Current excitation outputs (Ix+)

Table 21. Current excitation output specifications

Parameter	Specification
Configuration	4 dedicated pairs: $\pm\text{IA}$: CH0/CH1 $\pm\text{IB}$: CH2/CH3 $\pm\text{IC}$: CH4/CH5 $\pm\text{ID}$: CH6/CH7
Current excitation output ranges	Thermistor: 10 μA typ RTD: 210 μA typ
Tolerance	$\pm 5\%$ typ
Drift	200 ppm/ $^{\circ}\text{C}$
Line regulation	2.1 ppm/V max
Load regulation	0.3 ppm/V typ
Output compliance voltage (relative to AGND pins)	3.90 V max -0.03 V min

Note 18: The WEB-TEMP has four current excitation outputs, with $\pm\text{IA}$ dedicated to the CH0/CH1 analog inputs, $\pm\text{IB}$ dedicated to CH2/CH3, $\pm\text{IC}$ dedicated to CH4/CH5, and $\pm\text{ID}$ dedicated to CH6/CH7. The excitation output currents should always be used in this dedicated configuration.

Note 19: The current excitation outputs are automatically configured based on the sensor selected (thermistor or RTD).

Environmental

Table 22. Environmental specifications

Parameter	Specification
Operating temperature range	0 to 55 $^{\circ}\text{C}$
Storage temperature range	-40 to 85 $^{\circ}\text{C}$
Humidity	0 to 90% non-condensing

Mechanical

Table 23. Mechanical specifications

Parameter	Specification
Dimensions (L \times W \times H)	128.52 x 88.39 x 35.56 mm (5.06 x 3.48 x 1.43 ft)

Screw terminal connector

Table 24. Screw terminal connector specifications

Parameter	Specification
Connector type	Screw terminal
Wire gauge range	16 AWG to 30 AWG

Table 25. Screw terminal pinout

Pin	Signal Name	Pin Description	Pin	Signal Name	Pin Description
1	IA+	CH0/CH1 current excitation source	27	ID-	CH6/CH7 current excitation return
2	NC	No connection	28	AGND	Analog ground
3	C0H	CH0 sensor input (+)	29	C7L	CH7 sensor input (-)
4	C0L	CH0 sensor input (-)	30	C7H	CH7 sensor input (+)
5	4W01	CH0/CH1 4-wire, 2 sensor common	31	IC67	CH6/CH7 2 sensor common
6	IC01	CH0/CH1 2-sensor common	32	4W67	CH6/CH7 4-wire, 2 sensor common
7	C1H	CH1 sensor input (+)	33	C6L	CH6 sensor input (-)
8	C1L	CH1 sensor input (-)	34	C6H	CH6 sensor input (+)
9	AGND	Analog ground	35	NC	No connection
10	IA-	CH0/CH1 current excitation return	36	ID+	CH6/CH7 current excitation source
11	IB+	CH2/CH3 current excitation source	37	IC-	CH4/CH5 current excitation return
12	NC	No connection	38	AGND	Analog ground
13	C2H	CH2 sensor input (+)	39	C5L	CH5 sensor input (-)
14	C2L	CH2 sensor input (-)	40	C5H	CH5 sensor input (+)
15	4W23	CH2/CH3 4-wire, 2 sensor common	41	IC45	CH4/CH5 2 sensor common
16	IC23	CH2/CH3 2 sensor common	42	4W45	CH4/CH5 4-wire, 2 sensor common
17	C3H	CH3 sensor input (+)	43	C4L	CH4 sensor input (-)
18	C3L	CH3 sensor input (-)	44	C4H	CH4 sensor input (+)
19	AGND	Analog ground	45	NC	No connection
20	IB-	CH2/CH3 current excitation return	46	IC+	CH4/CH5 current excitation source
21	+5V	+5V output	47	NC	No connection
22	PU/D	Pull-up/down for digital outputs	48	GND	Digital ground
23	DIO0	DIO channel 0	49	DIO7	DIO channel 7
24	DIO1	DIO channel 1	50	DIO6	DIO channel 6
25	DIO2	DIO channel 2	51	DIO5	DIO channel 5
26	DIO3	DIO channel 3	52	DIO4	DIO channel 4

CE Declaration of Conformity

Manufacturer: Measurement Computing Corporation
Address: 10 Commerce Way
Suite 1008
Norton, MA 02766
USA
Category: Electrical equipment for measurement, control and laboratory use.

Measurement Computing Corporation declares under sole responsibility that the product

WEB-TEMP

EU EMC Directive 89/336/EEC: Electromagnetic Compatibility, EN 61326 (1997) Amendment 1 (1998)

Emissions: Group 1, Class A

- EN 55011 (1990)/CISPR 11: Radiated and Conducted emissions.

Immunity: EN61326, Annex A

- IEC 61000-4-2 (1995): Electrostatic Discharge immunity, Criteria B.
- IEC 61000-4-3 (1995): Radiated Electromagnetic Field immunity Criteria B.
- IEC 61000-4-4 (1995): Electric fast transient burst immunity Criteria B.
- IEC 61000-4-5 (1995): Surge immunity Criteria A.
- IEC 61000-4-6 (1996): Radio frequency common mode immunity Criteria B.
- IEC 61000-4-8 (1994): Power frequency magnetic field immunity Criteria A.
- IEC 61000-4-11 (1994): Interrupt immunity Criteria A.

Declaration of Conformity based on tests conducted by Chomerics Test Services, Woburn, MA 01801, USA in August, 2007. Test records are outlined in Chomerics Test Report #EMI4891A.07.

We hereby declare that the equipment specified conforms to the above Directives and Standards.



Carl Haapaoja, Director of Quality Assurance

Measurement Computing Corporation
10 Commerce Way
Suite 1008
Norton, Massachusetts 02766
(508) 946-5100
Fax: (508) 946-9500
E-mail: info@mccdaq.com
www.mccdaq.com