

USB-PDISO8/40

USB-based Isolated Input and Relay Output

User's Guide

Trademark and Copyright Information

Measurement Computing Corporation, InstaCal, Universal Library, and the Measurement Computing logo are either trademarks or registered trademarks of Measurement Computing Corporation. Refer to the Copyrights & Trademarks section on mccdaq.com/legal for more information about Measurement Computing trademarks. Other product and company names mentioned herein are trademarks or trade names of their respective companies.

© 2021 Measurement Computing Corporation. All rights reserved. No part of this publication may be reproduced, stored in a retrieval system, or transmitted, in any form by any means, electronic, mechanical, by photocopying, recording, or otherwise without the prior written permission of Measurement Computing Corporation.

Notice

Measurement Computing Corporation does not authorize any Measurement Computing Corporation product for use in life support systems and/or devices without prior written consent from Measurement Computing Corporation. Life support devices/systems are devices or systems that, a) are intended for surgical implantation into the body, or b) support or sustain life and whose failure to perform can be reasonably expected to result in injury. Measurement Computing Corporation products are not designed with the components required, and are not subject to the testing required to ensure a level of reliability suitable for the treatment and diagnosis of people.

Table of Contents

| | |
|--|-----------|
| Preface | |
| About this User's Guide | 4 |
| What you will learn from this user's guide | 4 |
| Conventions in this user's guide..... | 4 |
| Where to find more information..... | 4 |
| Chapter 1 | |
| Introducing the USB-PDISO8/40 | 5 |
| Functional block diagram | 5 |
| Chapter 2 | |
| Installing the USB-PDISO8/40 | 6 |
| Unpacking | 6 |
| Installing the software..... | 6 |
| Connecting the external power supply | 6 |
| Installing the hardware | 6 |
| Chapter 3 | |
| Functional Details | 8 |
| Components | 8 |
| USB IN connector | 8 |
| USB OUT connector..... | 8 |
| POWER IN connector..... | 9 |
| POWER OUT connector..... | 9 |
| USB LED..... | 9 |
| PWR LED..... | 9 |
| Signal I/O connector..... | 9 |
| Relay contacts..... | 10 |
| Differential isolated digital inputs | 10 |
| Cabling..... | 12 |
| Field wiring and signal termination accessories | 12 |
| Daisy chaining additional devices to the USB-PDISO8/40..... | 13 |
| Power limitations using multiple USB-PDISO8/40 devices | 13 |
| Supply current | 13 |
| Voltage drop..... | 14 |
| Relay contact protection circuit for inductive loads | 14 |
| Chapter 4 | |
| Specifications..... | 15 |
| Relay specifications | 15 |
| Isolated inputs | 15 |
| Power | 16 |
| External power output..... | 16 |
| USB specifications | 16 |
| Mechanical | 17 |
| Environmental | 17 |
| Main connector..... | 17 |
| P14 | 18 |
| Declaration of Conformity..... | 19 |
| Declaration of Conformity, Legacy Hardware | 20 |

About this User's Guide

What you will learn from this user's guide

This user's guide describes the Measurement Computing USB-PDISO8/40 data acquisition device and lists device specifications.

Conventions in this user's guide

For more information

Text presented in a box signifies additional information related to the subject matter.

Caution! Shaded caution statements present information to help you avoid injuring yourself and others, damaging your hardware, or losing your data.

Bold text is used for the names of objects on a screen, such as buttons, text boxes, and checkboxes.

Italic text is used for the names of manuals and help topic titles, and to emphasize a word or phrase.

Where to find more information

Additional information about USB-PDISO8/40 hardware is available on our website at www.mccdaq.com. You can also contact Measurement Computing Corporation with specific questions.

- Knowledgebase: kb.mccdaq.com
- Tech support form: www.mccdaq.com/support/support_form.aspx
- Email: techsupport@mccdaq.com
- Phone: 508-946-5100 and follow the instructions for reaching Tech Support

For international customers, contact your local distributor. Refer to the International Distributors section on our website at www.mccdaq.com/International.

Introducing the USB-PDISO8/40

The USB-PDISO8/40 is a USB 2.0 full-speed device that provides the following features:

- Eight single pole double throw (SPDT) Form C relay outputs that provide 6 A outputs at 240 VAC or 28 VDC.
- Eight isolated high voltage digital inputs that can monitor up to 30 V AC or DC inputs
- An optional input filter available on each isolated input (input filters are enabled and disabled by software)
- A 40-pin connector for field wiring connections
- USB out and power out connections support powering and controlling multiple MCC USB devices from one external power source and one USB port in a daisy-chain configuration.*
- Rugged enclosure that you can mount on a DIN rail or on a bench

The USB-PDISO8/40 is powered by an external 9 V, 1.67 A regulated power supply that is shipped with the device.

Functional block diagram

USB-PDISO8/40 functions are illustrated in the block diagram shown here.

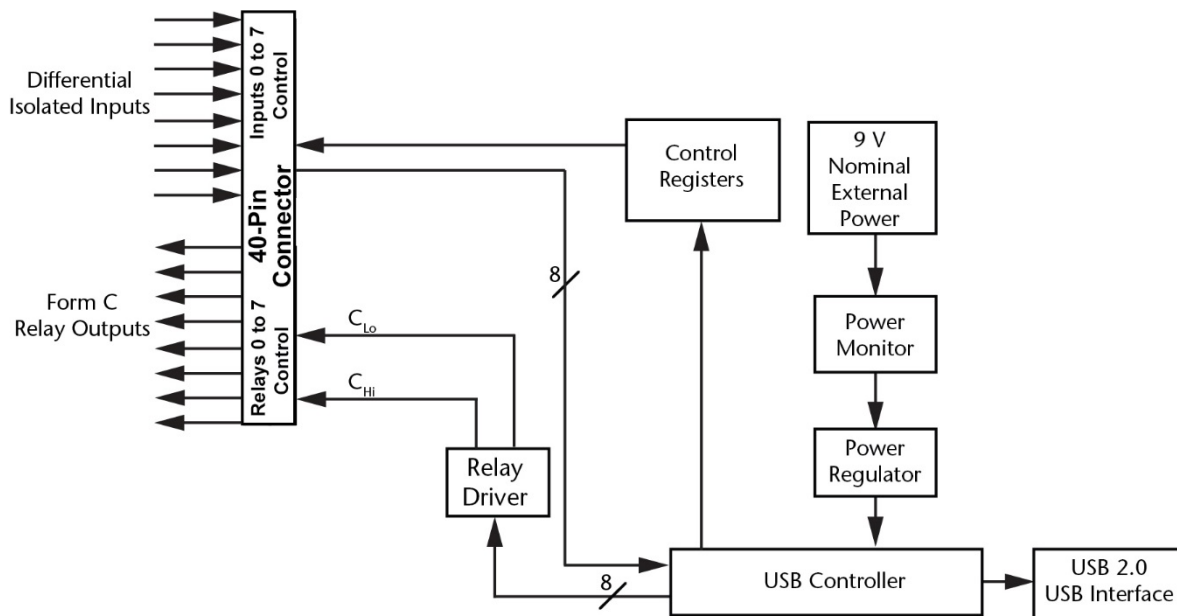

Figure 1. USB-PDISO8/40 functional block diagram

* Depending on your load requirements, daisy-chained devices may require a separate power supply.

Installing the USB-PDISO8/40

Unpacking

As with any electronic device, you should take care while handling to avoid damage from static electricity. Before removing the device from its packaging, ground yourself using a wrist strap or by simply touching the computer chassis or other grounded object to eliminate any stored static charge.

Contact us immediately if any components are missing or damaged.

Installing the software

Refer to the *MCC DAQ Quick Start* and the USB-PDISO8/40 product page on our website for information about the software supported by the USB-PDISO8/40.

Install the software before you install your device

The driver needed to run the USB-PDISO8/40 is installed with the software. Therefore, you need to install the software package you plan to use before you install the hardware.

Connecting the external power supply

Power to the USB-PDISO8/40 is provided with the +9 V external power supply (CB-PWR-9). You must connect the external power supply before connecting the USB cable to the USB-PDISO8/40 and your computer.

If you are connecting more than one MCC USB device, make sure that you provide adequate power to each device. Refer to Power limitations using multiple USB-PDISO8/40 devices on page 13.

To connect the power supply to your USB-PDISO8/40, connect the external power cord to the power connector labeled **POWER IN** on the USB-PDISO8/40 enclosure (**PWR IN** on the board). Refer to Figure 2 on page 8 for the location of this connector.

The green **PWR** LED lights when +9 V power is supplied to the USB-PDISO8/40. If the voltage supply is less than +6.5 V or more than +12.5 V, the **PWR** LED does not light.

Do not connect external power to the POWER OUT connector

The power connector labeled **POWER OUT** on the enclosure (**PWR OUT** on the board) is used to provide power to an additional MCC USB device. If you connect the external power supply to the **POWER OUT** connector, the USB-PDISO8/40 does not receive power, and the **PWR** LED does not light.

Installing the hardware

Connect the USB-PDISO8/40 using the cable provided to a USB port on a computer running Windows. Windows finds and installs the device driver automatically, and notifies you that the device is ready to use.

The **USB** LED turns on after the device is successfully installed.

You can connect up to four compatible MCC USB products in a daisy-chain configuration to a USB port on your computer.

If the USB LED turns off

If communication is lost between the device and the computer, the **USB** LED turns off. To restore communication, disconnect the USB cable from the computer and then reconnect it. This should restore communication, and the **USB** LED should turn on.

If your system does not detect the USB-PDISO8/40

If a USB device not recognized message displays when you connect the USB-PDISO8/40, complete the following steps:

1. Unplug the USB cable from the USB-PDISO8/40.
2. Unplug the external power cord from the **POWER IN** connector on the enclosure.
3. Plug the external power cord back into the **POWER IN** connector.
4. Plug the USB cable back into the USB-PDISO8/40.

Your system should now properly detect the USB-PDISO8/40.

Contact technical support if your system still does not detect the USB-PDISO8/40.

Functional Details

The USB-PDISO8/40 provides SPDT relay control and isolated inputs in a plug-and-play package. All I/O connections are made to a 40-pin connector (see Main connector and pin out on page 9).

Components

The USB-PDISO8/40 has the following internal components, as shown in Figure 2.

- Two USB connectors
- Two external power connectors
- USB LED
- PWR LED
- 40-pin I/O connector

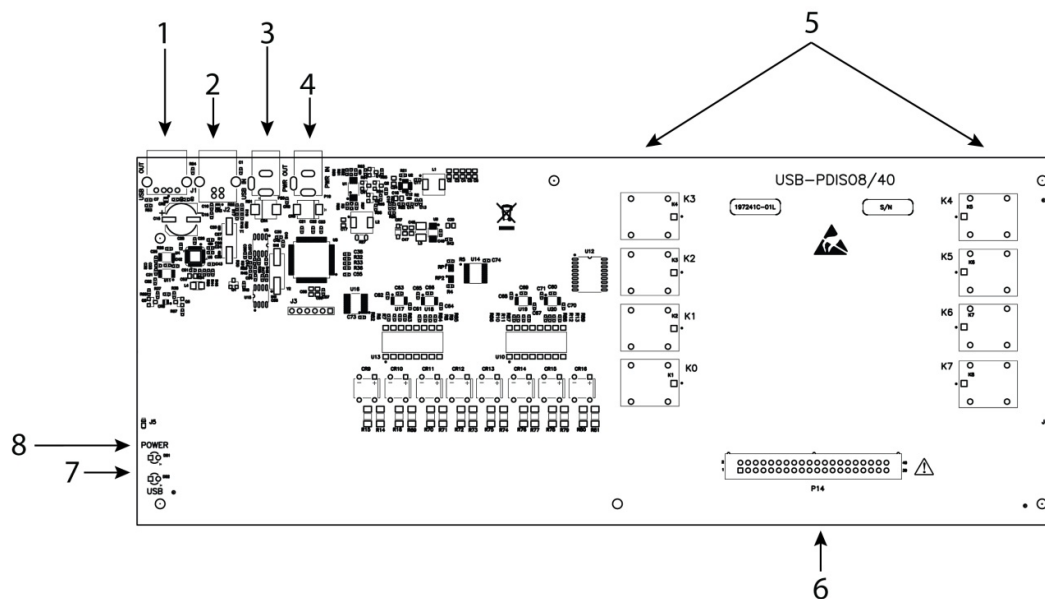

Figure 2. USB-PDISO8/40 components

- | | | | |
|---|---|---|------------------|
| 1 | USB output connector (USB OUT) | 5 | Relays |
| 2 | USB input connector (USB IN) | 6 | 40-pin connector |
| 3 | Power output connector (POWER OUT 9 VDC) | 7 | USB LED |
| 4 | Power input connector (POWER IN) | 8 | PWR LED |

USB IN connector

The USB in connector is labeled **USB IN** on the board and enclosure. This connector is a USB 2.0 full-speed input connector that you connect to the USB port on your computer (or USB hub connected to your computer). This connector supports USB 1.1 and USB 2.0 devices.

Hardware revision C and later are also compatible with USB 3.0. The board revision may be determined from the part number label on the enclosure that states "197242X-01," where X is the board revision.

USB OUT connector

The **USB OUT** connector is a downstream hub output port intended for use with other MCC USB products only. The USB hub is self-powered, and can provide 100 mA maximum current at 5 V.

For information on daisy chaining to other MCC USB devices, refer to *Daisy chaining additional devices to the USB-PDISO8/40* on page 13.

POWER IN connector

The USB-PDISO8/40 requires between 6.5 V and 12.5 V of external power. An external power connection is required to activate the relays and to run tests in InstaCal.

To supply external power, connect the **POWER IN** connector to the supplied +9 V external power supply (CB-PWR-9).

The USB specification allows high-power devices to draw up to 725 mA. When all eight relays are energized, the combined current draw exceeds the maximum allowed for high-power USB devices. Therefore, external power is required.

POWER OUT connector

Use the **POWER OUT** connector to provide power to additional daisy chained MCC USB devices from a single external power supply. A user-supplied custom cable is required to daisy chain multiple devices.

USB LED

The **USB** LED indicates the communication status of the USB-PDISO8/40. This LED uses up to 5 mA of current and cannot be disabled. The following table explains the function of the USB LED.

USB LED Indications

| USB LED | Indication |
|-------------|--|
| On steadily | The USB-PDISO8/40 is connected to a computer or external USB hub. |
| Blinking | Initial communication is established between the USB-PDISO8/40 and the computer, or data is being transferred. |

PWR LED

The USB-PDISO8/40 incorporates an onboard voltage supervisory circuit that monitors the USB VBUS (5 V) and the external 9 V power supply. If the input voltage falls outside of the specified ranges the **PWR** LED shuts off (see the following table).

PWR LED Indications

| PWR LED | Indication |
|---------|--|
| On | USB +5 V power or +9 V external power is supplied to the USB-PDISO8/40. |
| Off | Input power is not supplied, or a power fault has occurred. A power fault occurs when the input power falls outside of the specified voltage range: <ul style="list-style-type: none"> ■ USB VBUS (+5 V): 4.75 V to 5.25 V ■ External power: (+9 V): 6.5 V to 12.5 V |

Signal I/O connector

The table below lists the device connectors, applicable cables, and compatible accessory boards.

Board connectors, cables, accessory equipment

| | |
|---|--|
| Connector | P14: 40-pin ribbon connector |
| Compatible cables | C40FF-x: 40-conductor ribbon cable, female both ends, x = length in feet. C40-37F-x: 40-pin IDC to 37-pin female D connector, x = length in feet. |
| Compatible accessory products using the C40FF-x cable | CIO-MINI40 |
| Compatible accessory products using the C40-37F-x cable | CIO-MINI37 SCB-37 |

40-pin connector pin out (P14)

| Signal Name | Pin | | | Pin | Signal Name |
|---------------------------------|-----|---|---|-----|---------------------------------|
| Input 7 terminal A | 1 | • | • | 2 | Input 7 terminal B |
| Input 6 terminal A | 3 | • | • | 4 | Input 6 terminal B |
| Input 5 terminal A | 5 | • | • | 6 | Input 5 terminal B |
| Input 4 terminal A | 7 | • | • | 8 | Input 4 terminal B |
| Input 3 terminal A | 9 | • | • | 10 | Input 3 terminal B |
| Input 2 terminal A | 11 | • | • | 12 | Input 2 terminal B |
| Input 1 terminal A | 13 | • | • | 14 | Input 1 terminal B |
| Input 0 terminal A | 15 | • | • | 16 | Input 0 terminal B |
| Relay 7 Common contact | 17 | • | • | 18 | Relay 7 Normally Open contact |
| Relay 6 Common contact | 19 | • | • | 20 | Relay 6 Normally Open contact |
| Relay 5 Common contact | 21 | • | • | 22 | Relay 5 Normally Open contact |
| Relay 4 Normally Closed contact | 23 | • | • | 24 | Relay 4 Common contact |
| Relay 4 Normally Open contact | 25 | • | • | 26 | Relay 3 Normally Closed contact |
| Relay 3 Common contact | 27 | • | • | 28 | Relay 3 Normally Open contact |
| Relay 2 Normally Closed contact | 29 | • | • | 30 | Relay 2 Common contact |
| Relay 2 Normally Open contact | 31 | • | • | 32 | Relay 1 Normally Closed contact |
| Relay 1 Common contact | 33 | • | • | 34 | Relay 1 Normally Open contact |
| Relay 0 Normally Closed contact | 35 | • | • | 36 | Relay 0 Common contact |
| Relay 0 Normally Open contact | 37 | • | • | 38 | Relay 7 Normally Closed contact |
| Relay 5 Normally Closed contact | 39 | • | • | 40 | Relay 6 Normally Closed contact |

Relay contacts

Connect external devices to the relay contacts using the 40-pin connector on the USB-PDISO8/40. Each relay has a normally closed (NC), common (C), and normally open (NO) contact.

Form C relay output

A schematic for Form C relay contacts is shown in Figure 3. The Form C relay has a C, NO, and NC contact.

- When a (0) is written to the output bit, the C and NC are in contact.
- When a (1) is written to the output bit, the C and NO are in contact.

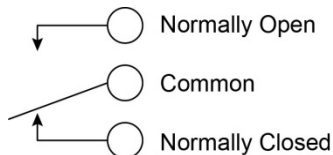

Figure 3. Form C SPDT relay

Differential isolated digital inputs

Connect up to eight isolated digital input signals using the 40-pin connector:

- Input 0 terminal A and input 0 terminal B
- Input 1 terminal A and input 1 terminal B
- Input 2 terminal A and input 2 terminal B
- Input 3 terminal A and input 3 terminal B
- Input 4 terminal A and input 4 terminal B
- Input 5 terminal A and input 5 terminal B
- Input 6 terminal A and input 6 terminal B
- Input 7 terminal A and input 7 terminal B

A schematic of a single channel is shown in Figure 6. Each signal is applied to a bridge rectifier so that the input is not polarity-sensitive. Each input channel can be driven by either AC (50 - 1000 Hz) or DC voltage.

The optically isolated (500 V) inputs can be read back as a single byte. Each input has a software-selectable filter with a time constant of 5 ms (200 Hz). The filter is required for AC inputs, and recommended for almost all DC inputs. Unless you have a good reason to turn off a filter, MCC recommends that you enable it.

You can enable and disable (default) each input filter by selecting the device and then selecting **Install»Configure** in InstaCal.

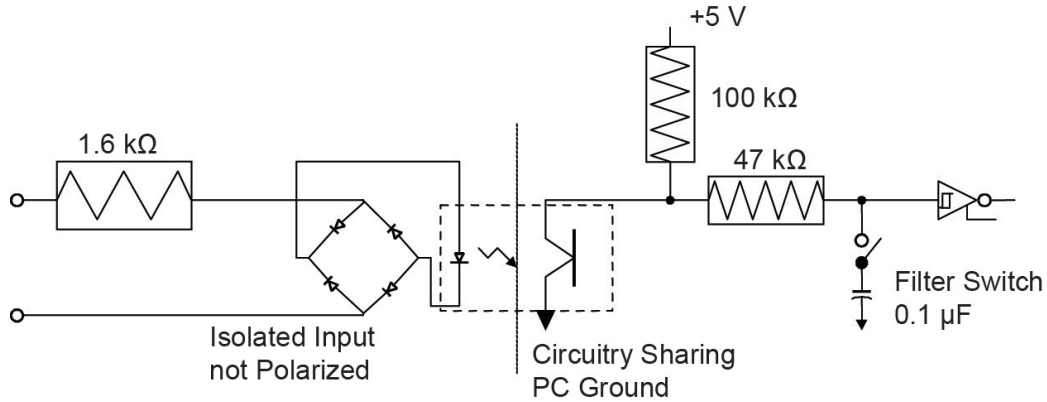

Figure 4. USB-PDISO8/40 single-channel configuration

Figure 5 shows a schematic of a simple connection from a +9 V battery to the relay 4 connector pins. When the relay is energized, relay 4 NO connects the battery voltage to input 4 terminal B.

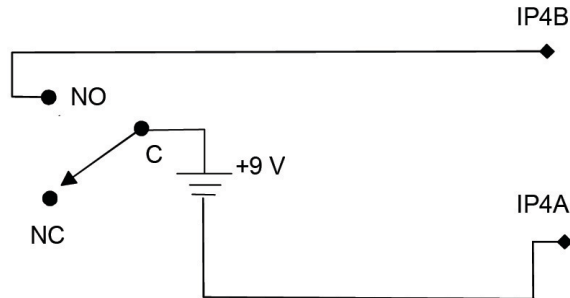

Figure 5. Schematic of battery-to-relay connection

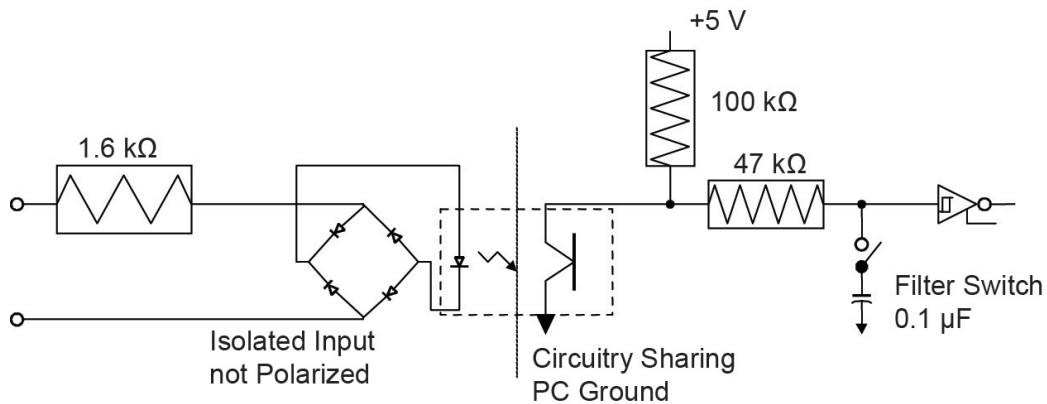

Figure 6. USB-PDISO8/40 single-channel configuration

Cabling

For signal connections and termination, you can use the CIO-MINI40 screw terminal board and C40FF-x cable.

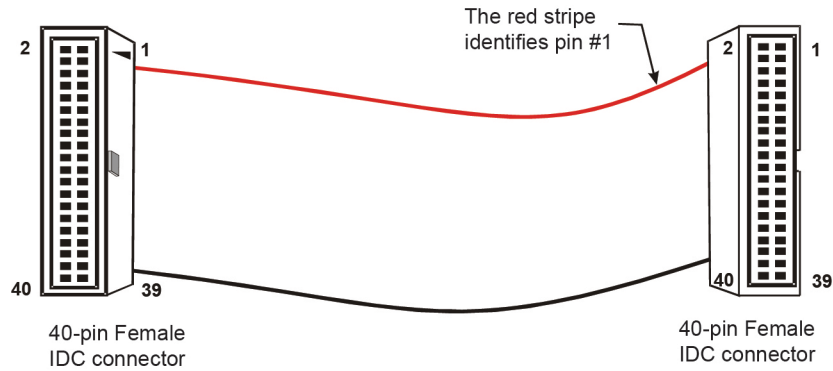

Figure 7. C40FF-x cable

For connections to 37-pin connectors or boards, you can use the C40-37F-x or C40F-37M-x cable.

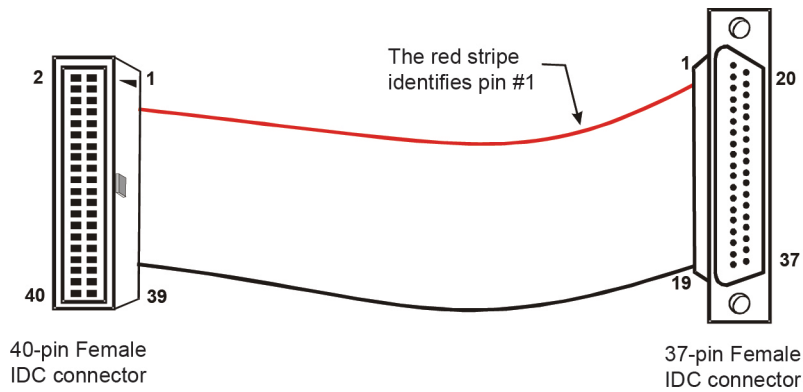

Figure 8. C40-37F-x cable

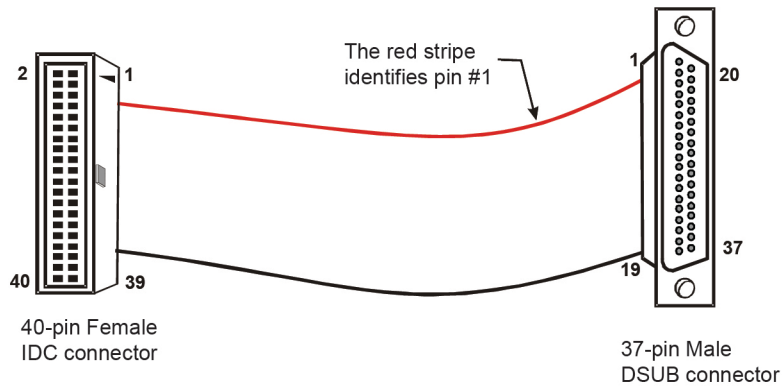

Figure 9. C40-37M-x cable

Field wiring and signal termination accessories

Use the following screw terminal boards to terminate field signals and route them into the USB-PDISO8/40 using the cables above.

- CIO-MINI40 – 40-pin screw terminal board.
- CIO-MINI37 – 37-pin screw terminal board.
- SCB-37 – 37-conductor, shielded signal connection box.

Daisy chaining additional devices to the USB-PDISO8/40

Daisy-chained USB-PDISO8/40 devices connect to the USB bus through the high-speed hub on the USB-PDISO8/40. You can daisy chain up to four MCC USB devices that support daisy-chain configurations to a single USB 2.0 port or USB 1.1 port on your computer.

Use the supplied cable or an equivalent full-speed cable when daisy chaining to other MCC USB devices.

- The device already connected to the computer is referred to as the host device.
- The additional device(s) that you want to daisy chain to the host USB-PDISO8/40 is referred to as the slave device.

This procedure assumes you already have a host device connected to a computer and to an external power source.

To daisy chain MCC USB devices, complete the following steps below.

1. Connect the **POWER OUT** connector on the host device to the **POWER IN** connector on the slave device.
This step is required only if you plan to daisy chain power to another device.
2. Connect the **USB OUT** connector on the host device to the **USB IN** connector on the slave device.
3. To add another device, repeat steps 1-2 by connecting the slave device to another slave device.

A daisy chain example is shown in Figure 10. Note that the last board in the chain is supplied with external power.

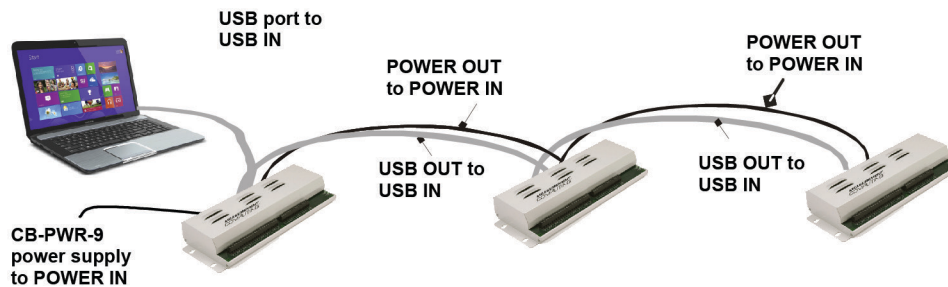

Figure 10. USB-PDISO8/40 daisy-chain connections (configuration not near full power load)

Power limitations using multiple USB-PDISO8/40 devices

When daisy chaining additional MCC USB products to the USB-PDISO8/40, make sure that you provide adequate power to each device that you connect. The USB-PDISO8/40 is powered with a 9 VDC nominal, 1.67 A external power supply.

When connecting multiple devices, power supplies with higher current capability – such as the CB PWR-9V3A – are available from MCC.

Supply current

Running one USB-PDISO8/40 with all relays on draws 820 mA from the 1.67 A supply. When using the USB-PDISO8/40 under full load conditions, you cannot daisy chain additional MCC USB products unless you supply external power to each device in the chain.

If you are not sure how much current your application requires, we recommend that you provide separate power to each MCC USB product that you connect.

Voltage drop

A drop in voltage occurs with each device connected in a daisy chain system. The voltage drop between the device power supply input and the daisy chain output is 0.5 V maximum. Factor in this voltage drop when you configure a daisy chain system to ensure that at least 6.5 VDC is provided to the last device in the chain. Always provide a separate power supply when the USB-PDISO8/40 is the last device in the chain.

Relay contact protection circuit for inductive loads

When you connect an inductive load to a relay, energy stored in the inductive load can induce a large voltage surge when you switch the relay. This voltage can severely damage the relay contacts. To limit the voltage surge across the inductive load in a DC circuit, install a kickback diode across the inductive load. Refer to the contact protection circuit in Figure 11. For AC loads, install a metal oxide varistor (MOV).

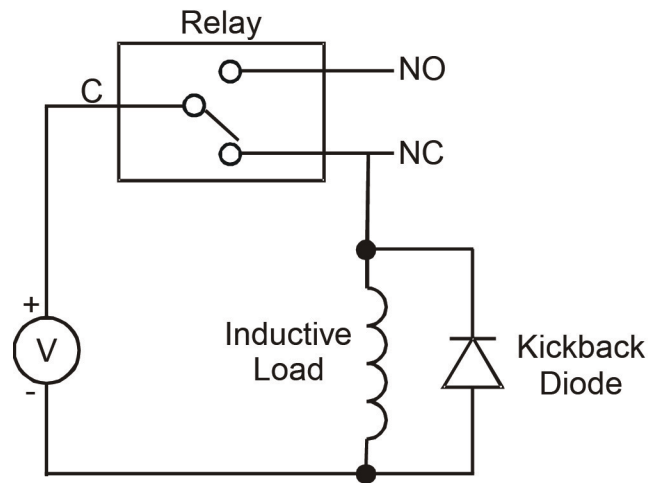

Figure 11. Relay contact protection circuit

Specifications

All specifications are subject to change without notice.

Typical for 25 °C unless otherwise specified.

Specifications in *italic text* are guaranteed by design.

Relay specifications

Table 1. Relay output specifications

| | |
|-----------------------------|--|
| Number | 8 |
| Contact configuration | 8 FORM C (SPDT) NO, NC and Common available at connector |
| <i>Contact rating</i> | <i>6 A @ 240 VAC or 28 VDC resistive (see Main connector on page 17)</i> |
| Contact resistance | 100 mΩ max |
| <i>Operate time</i> | <i>10 ms max</i> |
| <i>Release time</i> | <i>10 ms max</i> |
| <i>Vibration</i> | <i>10 Hz to 55 Hz (dual amplitude 1.5 mm)</i> |
| <i>Shock</i> | <i>10 G (11 ms)</i> |
| <i>Dielectric isolation</i> | <i>500 V (1 minute)</i> |
| <i>Life expectancy</i> | <i>10 million mechanical operations, min</i> |
| Power on RESET state | Not energized. NC in contact to Common. |

Isolated inputs

Table 2. Isolated input specifications

| | | |
|------------------|------------------|---|
| Number | 8 | |
| <i>Isolation</i> | <i>500 V</i> | |
| Resistance | 1.6 KΩ min | |
| Voltage range | DC | Input high: +5.0 VDC min or -5.0 VDC min |
| | | Input low: +1.5 VDC max or -1.5 VDC max |
| | | Input range: 30 VDC max |
| | AC (with filter) | Input high: 6.0 V _{rms} min (50 Hz to 1000 Hz) |
| | | Input low: 1.5 V _{rms} max (50 Hz to 1000 Hz) |
| Response | Filter disabled | 20 μs |
| | Filter enabled | 5 ms |
| Filters | Time constant | 5 ms (200 Hz) |
| | Filter control | Software-selectable for each input. |
| | Power-up /reset | Filters disabled |

Power

Table 3. Power specifications

| Parameter | Conditions | Specification |
|-------------------------------------|--|-----------------------------|
| USB +5 V input voltage range. | | 4.75 V to 5.25 V |
| USB +5 V supply current | All modes of operation | 10 mA max |
| External power input | | 9 V nominal |
| External power supply (required) | MCC p/n CB-PWR-9 | 9 V @ 1.67 A |
| Voltage supervisor limits - PWR LED | $6.5\text{ V} > V_{\text{ext}}$ or $V_{\text{ext}} > 12.5\text{ V}$ (Note 1) | PWR LED = Off (power fault) |
| | $6.5\text{ V} \leq V_{\text{ext}} < 12.5\text{ V}$ | PWR LED = On |
| External power consumption | All relays on, 100 mA downstream hub power | 820 mA typ, 900 mA max |
| | All relays off, 0 A downstream hub power | 200 mA typ, 230 mA max |

Note 1: The USB-PDISO8/40 monitors the external +9 V power supply voltage with a voltage supervisory circuit. If this power supply exceeds its specified limit, the **PWR** LED turns off, indicating a power fault condition.

External power output

Table 4. External power output specifications

| Parameter | Conditions | Specification |
|--|---|---------------|
| External power output - current range (Note 2) | | 4.0 A max |
| External power output | Voltage drop between power input and daisy chain power output | 0.5 V max |

Note 2: The daisy chain power output option allows multiple Measurement Computing USB products with a USB hub output port to be powered from a single external-power source in a daisy-chain fashion. The voltage drop between the device power supply input and the daisy-chain output is 0.5 V maximum. Users must plan for this drop to assure the last device in the chain receives at least 6.5 VDC. A user-supplied custom cable is required to daisy chain multiple devices.

USB specifications

Table 5. USB specifications

| | |
|--|---|
| USB "B" connector | Input |
| USB device type | USB 2.0 (full speed) |
| Device compatibility | USB 1.1, USB 2.0 (hardware revision C and later are also compatible with USB 3.0; see Note 3 for information on how to determine the hardware revision) |
| USB "A" connector | Downstream hub output port |
| USB hub type | Supports USB 2.0 high-speed, full-speed and low-speed operating points |
| | Self-powered, 100 mA max downstream VBUS capability |
| Compatible products | MCC USB products with a USB hub output port |
| USB cable type (upstream and downstream) | A-B cable, UL type AWM 2527 or equivalent. (min 24 AWG VBUS/GND, min 28 AWG D+/D-) |
| USB cable length | 3 meters max |

Note 3: The board revision may be determined from the part number label on the housing that states "197242X-01," where X is the board revision.

Mechanical

Table 6. Mechanical specifications

| | |
|----------------------------------|--|
| Board dimensions (L × W × H) | 304.3 × 121.9 × 17.8 mm (12.0 × 4.8 × 0.7 in.) |
| Enclosure dimensions (L × W × H) | 342.9 × 125.7 × 58.9 mm (13.5 × 4.95 × 2.32 in.) |

Environmental

Table 7. Environmental specifications

| | |
|-----------------------------|--------------------------|
| Operating temperature range | 0 °C to 70 °C |
| Storage temperature range | -40 °C to 85 °C |
| Humidity | 0% to 95% non-condensing |

Main connector

Table 8. Main connector specifications

| | |
|--|---|
| Connector type | P14: 40-pin header |
| Compatible cables | C40FF-x: 40-conductor ribbon cable, female both ends, x = length in feet. |
| | C40-37F-x: 40-pin IDC to 37-pin female D connector, x = length in feet. |
| Compatible accessory products (using the C40FF-x cable) | CIO-MINI40 |
| Compatible accessory products (using the C40-37F-x cable) | CIO-MINI37 SCB-37 |
| Max current | 1 A |

P14

| Pin | Signal Name | Pin | Signal Name |
|-----|---------------------------------|-----|---------------------------------|
| 1 | Input 7 terminal A | 2 | Input 7 terminal B |
| 3 | Input 6 terminal A | 4 | Input 6 terminal B |
| 5 | Input 5 terminal A | 6 | Input 5 terminal B |
| 7 | Input 4 terminal A | 8 | Input 4 terminal B |
| 9 | Input 3 terminal A | 10 | Input 3 terminal B |
| 11 | Input 2 terminal A | 12 | Input 2 terminal B |
| 13 | Input 1 terminal A | 14 | Input 1 terminal B |
| 15 | Input 0 terminal A | 16 | Input 0 terminal B |
| 17 | Relay 7 Common contact | 18 | Relay 7 Normally Open contact |
| 19 | Relay 6 Common contact | 20 | Relay 6 Normally Open contact |
| 21 | Relay 5 Common contact | 22 | Relay 5 Normally Open contact |
| 23 | Relay 4 Normally Closed contact | 24 | Relay 4 Common contact |
| 25 | Relay 4 Normally Open contact | 26 | Relay 3 Normally Closed contact |
| 27 | Relay 3 Common contact | 28 | Relay 3 Normally Open contact |
| 29 | Relay 2 Normally Closed contact | 30 | Relay 2 Common contact |
| 31 | Relay 2 Normally Open contact | 32 | Relay 1 Normally Closed contact |
| 33 | Relay 1 Common contact | 34 | Relay 1 Normally Open contact |
| 35 | Relay 0 Normally Closed contact | 36 | Relay 0 Common contact |
| 37 | Relay 0 Normally Open contact | 38 | Relay 7 Normally Closed contact |
| 39 | Relay 5 Normally Closed contact | 40 | Relay 6 Normally Closed contact |

CE Declaration of Conformity
According to ISO/IEC 17050-1:2010

Manufacturer: Measurement Computing Corporation
Address: 10 Commerce Way
Norton, MA 02766
USA
Product Category: Electrical equipment for measurement, control and laboratory use.
Date and Place of Issue: May 3, 2016, Norton, Massachusetts USA
Test Report Number: EMI4813.07

Measurement Computing Corporation declares under sole responsibility that the product
USB-PDISO8/40, Product Revision C* or later

Complies with the essential requirements of the following applicable European Directives:

Electromagnetic Compatibility (EMC) Directive 2014/30/EU
Low Voltage Directive 2014/35/EU
RoHS Directive 2011/65/EU

Conformity is assessed in accordance to the following standards:

EMC:

Emissions:

- EN 61326-1:2013 (IEC 61326-1:2012), Class A
- EN 55011: 2009 + A1:2010 (IEC CISPR 11:2009 + A1:2010), Group 1, Class A

Immunity:

- EN 61326-1:2013 (IEC 61326-1:2012), Controlled EM Environments
- EN 61000-4-2:2008 (IEC 61000-4-2:2008)
- EN 61000-4-3 :2010 (IEC61000-4-3:2010)
- EN 61000-4-4 :2012 (IEC61000-4-4:2012)
- EN 61000-4-5 :2014 (IEC61000-4-5:2014)
- EN 61000-4-6 :2013 (IEC61000-4-6:2013)
- EN 61000-4-11:2004 (IEC61000-4-11:2004)

Safety:

- EN 61010-1 (IEC 61010-1)

Environmental Affairs:

Articles manufactured on or after the Date of Issue of this Declaration of Conformity do not contain any of the restricted substances in concentrations/applications not permitted by the RoHS Directive.



Carl Haapaoja, Director of Quality Assurance

*The board revision may be determined from the part number label on the board that states "197241X-01L", where X is the board revision.

CE Declaration of Conformity, Legacy Hardware

Manufacturer: Measurement Computing Corporation
Address: 10 Commerce Way
Norton, MA 02766
USA

Category: Electrical equipment for measurement, control and laboratory use.

Measurement Computing Corporation declares under sole responsibility that the product

USB-PDISO8/40, Product Revisions up to B*

to which this declaration relates is in conformity with the relevant provisions of the following standards or other documents:

EU EMC Directive 89/336/EEC: Electromagnetic Compatibility, EN 61326 (1997) Amendment 1 (1998)

Emissions: Group 1, Class A

- EN 55011 (1990)/CISPR 11: Radiated and Conducted emissions.

Immunity: EN61326, Annex A

- IEC 61000-4-2 (1995): Electrostatic Discharge immunity, Criteria C.
- IEC 61000-4-3 (1995): Radiated Electromagnetic Field immunity Criteria A.
- IEC 61000-4-4 (1995): Electric Fast Transient Burst immunity Criteria B.
- IEC 61000-4-5 (1995): Surge immunity Criteria B.
- IEC 61000-4-6 (1996): Radio Frequency Common Mode immunity Criteria A.
- IEC 61000-4-8 (1994): Power Frequency Magnetic Field immunity Criteria A.
- IEC 61000-4-11 (1994): Voltage Dip and Interrupt immunity Criteria A.

Declaration of Conformity based on tests conducted by Chomerics Test Services, Woburn, MA 01801, USA in June, 2007. Test records are outlined in Chomerics Test Report # EMI4813.07.

We hereby declare that the equipment specified conforms to the above Directives and Standards.



Carl Haapaoja, Director of Quality Assurance

*The board revision may be determined from the part number label on the board that states "197241X-01L", where X is the board revision.

Measurement Computing Corporation
10 Commerce Way
Norton, Massachusetts 02766
(508) 946-5100
Fax: (508) 946-9500
E-mail: info@mccdaq.com
www.mccdaq.com

NI Hungary Kft
H-4031 Debrecen, Hátar út 1/A, Hungary
Phone: +36 (52) 515400
Fax: +36 (52) 515414
<http://hungary.ni.com/debrecen>