

**DT9850 Series
User's Manual**

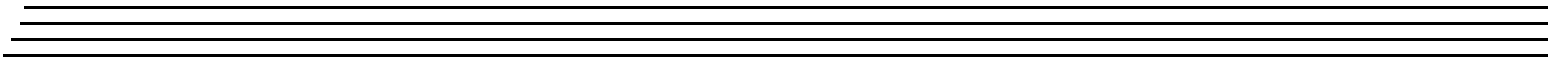
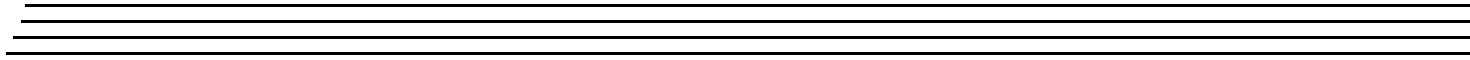
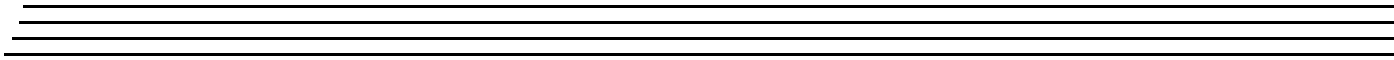

Trademark and Copyright Information

Measurement Computing Corporation, InstaCal, Universal Library, and the Measurement Computing logo are either trademarks or registered trademarks of Measurement Computing Corporation. Refer to the Copyrights & Trademarks section on mccdaq.com/legal for more information about Measurement Computing trademarks. Other product and company names mentioned herein are trademarks or trade names of their respective companies.

© 2015 Measurement Computing Corporation. All rights reserved. No part of this publication may be reproduced, stored in a retrieval system, or transmitted, in any form by any means, electronic, mechanical, by photocopying, recording, or otherwise without the prior written permission of Measurement Computing Corporation.

Notice

Measurement Computing Corporation does not authorize any Measurement Computing Corporation product for use in life support systems and/or devices without prior written consent from Measurement Computing Corporation. Life support devices/systems are devices or systems that, a) are intended for surgical implantation into the body, or b) support or sustain life and whose failure to perform can be reasonably expected to result in injury. Measurement Computing Corporation products are not designed with the components required, and are not subject to the testing required to ensure a level of reliability suitable for the treatment and diagnosis of people.

Radio and Television Interference

This equipment has been tested and found to comply with CISPR EN55022 Class A and EN61000-6-1 requirements and also with the limits for a Class A digital device, pursuant to Part 15 of the FCC Rules. These limits are designed to provide reasonable protection against harmful interference when the equipment is operated in a commercial environment. This equipment generates, uses, and can radiate radio frequency energy and, if not installed and used in accordance with the instruction manual, may cause harmful interference to radio communications. Operation of this equipment in a residential area is likely to cause harmful interference, in which case the user will be required to correct the interference at his own expense.

Changes or modifications to this equipment not expressly approved by Data Translation could void your authority to operate the equipment under Part 15 of the FCC Rules.

Note: This product was verified to meet FCC requirements under test conditions that included use of shielded cables and connectors between system components. It is important that you use shielded cables and connectors to reduce the possibility of causing interference to radio, television, and other electronic devices.

Canadian Department of Communications Statement

This digital apparatus does not exceed the Class A limits for radio noise emissions from digital apparatus set out in the Radio Interference Regulations of the Canadian Department of Communications.

Le présent appareil numérique n'émet pas de bruits radioélectriques dépassant les limites applicables aux appareils numériques de la class A prescrites dans le Règlement sur le brouillage radioélectrique édicté par le Ministère des Communications du Canada.

Table of Contents

| | |
|--|-----------|
| About this Manual | 9 |
| Intended Audience..... | 9 |
| How this Manual is Organized | 9 |
| Conventions Used in this Manual | 10 |
| Related Information..... | 10 |
| Where To Get Help..... | 10 |
| | |
| Chapter 1: Overview | 11 |
| DT9850 Series Hardware Features..... | 12 |
| Supported Software..... | 14 |
| Getting Started Procedure..... | 15 |
| | |
| Part 1: Getting Started | 17 |
| | |
| Chapter 2: Setting Up and Installing the Module | 19 |
| Unpacking..... | 21 |
| System Requirements | 22 |
| Attaching Modules to the Computer..... | 23 |
| Connecting Directly to the USB Port | 24 |
| Connecting to an Expansion Hub | 25 |
| Configuring the DT9850 Series Device Driver..... | 27 |
| | |
| Chapter 3: Wiring Signals | 29 |
| Preparing to Wire Signals | 31 |
| Wiring Recommendations | 31 |
| Wiring Signals to the DT9850 Series Module | 31 |
| Connecting an Analog Output Signal | 36 |
| Connecting Voltage Output Signals..... | 36 |
| Connecting Current Output Signals..... | 36 |
| Connecting Digital I/O Signals | 38 |
| Configuring the State of the Digital Input Signals..... | 38 |
| Connecting Digital Input Signals | 39 |
| Connecting Digital Output Signals..... | 39 |
| Connecting Event Counting Signals | 40 |
| | |
| Chapter 4: Verifying the Operation of a Module | 41 |
| Running the Quick DataAcq Application | 43 |
| Testing Single-Value Analog Output | 44 |
| Testing Continuous Analog Output | 45 |
| Testing Single-Value Digital Input..... | 46 |

| | |
|---|-----------|
| Testing Single-Value Digital Output | 47 |
| Part 2: Using Your Module..... | 49 |
| Chapter 5: Principles of Operation | 51 |
| Analog Output Features | 53 |
| Analog Output Channels | 53 |
| Output Ranges and Gains | 53 |
| Output Resolution..... | 54 |
| Output Clock (Continuous Mode Only) | 54 |
| Operation Modes..... | 55 |
| Updating a Single Analog Output Channel | 55 |
| Simultaneously Updating Analog Output Channels on One Module with a Single Value | 55 |
| Simultaneously Updating Analog Output Channels on Multiple Modules with a Single Value | 55 |
| Continuously Updating Analog Output Channels on One Module with a Waveform | 57 |
| Data Transfer | 58 |
| Data Format | 58 |
| Digital I/O Features..... | 60 |
| Digital I/O Lines..... | 60 |
| Resolution..... | 60 |
| Interrupts | 60 |
| Operation Modes..... | 61 |
| Counter/Timer Features | 62 |
| Chapter 6: Supported Device Driver Capabilities..... | 63 |
| Data Flow and Operation Options..... | 65 |
| Buffering | 66 |
| Triggered Scan Mode | 66 |
| Data Encoding..... | 66 |
| Channels | 67 |
| Gain | 67 |
| Ranges | 68 |
| Resolution | 68 |
| Current and Resistance Support | 69 |
| Thermocouple, RTD, and Thermistor Support | 70 |
| IEPE Support..... | 71 |
| Bridge and Strain Gage Support | 71 |
| Start Triggers..... | 72 |
| Reference Triggers | 73 |
| Clocks..... | 73 |

Counter/Timers 74

Tachometers..... 75

Chapter 7: Troubleshooting 77

General Checklist 78

Technical Support 80

If Your Module Needs Factory Service 81

Chapter 8: Calibration 83

Using the Calibration Utility 84

Calibrating the Analog Output Subsystem 85

Appendix A: Specifications 87

Analog Output Specifications..... 88

Digital I/O Specifications 90

Counter/Timer Specifications 91

DAC_Sync Trigger Specifications 92

Power, Physical, and Environmental Specifications 93

Regulatory Specifications 94

Appendix B: Screw Terminal Assignments 95

DT9853 Screw Terminal Assignments..... 96

DT9853-M Screw Terminal Assignments 97

DT9854 Screw Terminal Assignments..... 98

DT9854-M Screw Terminal Assignments 99

LED Status Indicators 100

Index 101

About this Manual

The first part of this manual describes how to install and set up your DT9850 Series module and device driver, and verify that your module is working properly.

The second part of this manual describes the features of the DT9850 Series modules, the capabilities of the DT9850 Series Device Driver, and how to program a DT9850 Series module using the DT-Open Layers for .NET Class Library™ software. Troubleshooting information is also provided.

Note: For more information on the class library, refer to the *DT-Open Layers for .NET Class Library User's Manual*. If you are using the DataAcq SDK or a software application to program your device, refer to the documentation for that software for more information.

Intended Audience

This document is intended for engineers, scientists, technicians, or others responsible for using and/or programming the DT9850 Series modules for data acquisition operations in the Microsoft® Vista®, Windows 7, or Windows 8 operating system. It is assumed that you have some familiarity with data acquisition principles and that you understand your application.

How this Manual is Organized

This manual is organized as follows:

- [Chapter 1, “Overview,”](#) describes the major features of the DT9850 Series module, as well as the supported software and accessories for the modules.
- [Chapter 2, “Setting Up and Installing the Module,”](#) describes how to install a DT9850 Series module and configure the device driver.
- [Chapter 3, “Wiring Signals,”](#) describes how to wire signals to a DT9850 Series module.
- [Chapter 4, “Verifying the Operation of a Module,”](#) describes how to verify the operation of the DT9850 Series module with the Quick DataAcq application.
- [Chapter 5, “Principles of Operation,”](#) describes all of the features of the DT9850 Series module and how to use them in your application.
- [Chapter 6, “Supported Device Driver Capabilities,”](#) lists the data acquisition subsystems and the associated features accessible using the DT9850 Series Device Driver.
- [Chapter 7, “Troubleshooting,”](#) provides information that you can use to resolve problems with the DT9850 Series module and device driver, should they occur.
- [Chapter 8, “Calibration,”](#) describes how to calibrate the analog output circuitry of the DT9850 Series modules.
- [Appendix A, “Specifications,”](#) lists the specifications of the DT9850 Series modules.

- [Appendix B, “Screw Terminal Assignments,”](#) lists the screw terminal assignments for the modules.
- An index completes this manual.

Conventions Used in this Manual

The following conventions are used in this manual:

- Notes provide useful information or information that requires special emphasis, cautions provide information to help you avoid losing data or damaging your equipment, and warnings provide information to help you avoid catastrophic damage to yourself or your equipment.
- Items that you select or type are shown in **bold**.

Related Information

Refer to the following documents for more information on using the DT9850 Series module:

- *Benefits of the Universal Serial Bus for Data Acquisition*. This white paper describes why USB is an attractive alternative for data acquisition. It is available on the Data Translation web site (www.mccdaq.com).
- *DT-Open Layers for .NET User’s Manual (UM-22161)*. For programmers who are developing their own application programs using Visual C# or Visual Basic .NET, this manual describes how to use the DT-Open Layers for .NET Class Library to access the capabilities of Data Translation data acquisition devices.
- *DataAcq SDK User’s Manual (UM-18326)*. For programmers who are developing their own application programs using the Microsoft C compiler, this manual describes how to use the DT-Open Layers DataAcq SDK™ to access the capabilities of Data Translation data acquisition devices.
- *LV-Link Online Help*. This help file describes how to use LV-Link™ with the LabVIEW™ graphical programming language to access the capabilities of Data Translation data acquisition devices.
- Microsoft Windows Vista, Windows 7, or Windows 8 documentation.
- USB web site (<http://www.usb.org>).

Where To Get Help

Should you run into problems installing or using a DT9850 Series module, the Data Translation Technical Support Department is available to provide technical assistance. Refer to [Chapter 7](#) for more information. If you are outside the United States or Canada, call your local distributor, whose number is listed on our web site (www.mccdaq.com).



Overview

| | |
|--------------------------------------|----|
| DT9850 Series Hardware Features..... | 12 |
| Supported Software..... | 14 |
| Getting Started Procedure..... | 15 |

DT9850 Series Hardware Features

The DT9850 Series is a family of low-cost analog output and digital I/O modules for the USB (Ver. 2.0 or Ver. 1.1) bus. The DT9850 Series includes the DT9853, DT9853-M, DT9854, and DT9854-M modules. [Figure 1](#) shows a DT9850 Series module.



Figure 1: DT9850 Series Module

Table 1 lists the key differences of each module in the series.

Table 1: Key Differences of the DT9850 Series Modules

| Module | # of Analog Outputs | ± 10 V and 0 to 10 V Outputs | 0 to 20 mA Current Output |
|----------|---------------------|----------------------------------|---------------------------|
| DT9853 | 4 | Yes | No |
| DT9853-M | 4 | Yes | Yes |
| DT9854 | 8 | Yes | No |
| DT9854-M | 8 | Yes | Yes |

All DT9850 Series modules share the following major features:

- Analog output resolution of 16 bits
- Analog output range of ± 10 V or 0 to 10 V
- Update analog output channels with a continuous waveform or with a single value
- Bidirectional DAC_Sync pin that you can use to update the analog output channels of multiple modules simultaneously
- One dedicated 8-bit digital input port with interrupt on change capability on seven lines for monitoring critical signals
- Digital input lines configurable for pull-up or pull-down
- One dedicated 8-bit digital output port
- 32-bit counter/timer for event counting applications
- ± 300 V galvanic isolation to the host computer

Supported Software

The following software is available for use with the DT9850 Series module and is on the Data Acquisition OMNI CD:

- **DT9850 Series Device Driver** – The device driver allows you to use a DT9850 Series module with any of the supported software packages or utilities.
- **Quick DataAcq application** – The Quick DataAcq application provides a quick way to get up and running using a DT9850 Series module. Using this application, you can verify key features of the modules, display data on the screen, and save data to disk.
- **DT-Open Layers for .NET Class Library** – Use this class library if you want to use Visual C# or Visual Basic for .NET to develop your own application software for a DT9850 Series module using Visual Studio 2003 - 2012; the class library complies with the DT-Open Layers standard.
- **DataAcq SDK** – Use the Data Acq SDK if you want to use Visual Studio 6.0 and Microsoft C or C++ to develop your own application software for a DT9850 Series module using Windows Vista, Windows 7, or Windows 8; the DataAcq SDK complies with the DT-Open Layers standard.
- **DAQ Adaptor for MATLAB** – Data Translation's DAQ Adaptor provides an interface between the MATLAB Data Acquisition (DAQ) subsystem from The MathWorks and Data Translation's DT-Open Layers architecture.
- **LV-Link** – An evaluation version of LV-Link is included on the Data Acquisition OMNI CD. Use LV-Link if you want to use the LabVIEW graphical programming language to access the capabilities of the DT9850 Series module.

Refer to the Data Translation web site (www.mccdaq.com) for information about selecting the right software package for your needs.

Getting Started Procedure

The flow diagram shown in [Figure 2](#) illustrates the steps needed to get started using the DT9850 Series module. This diagram is repeated in each Getting Started chapter; the shaded area in the diagram shows you where you are in the getting started procedure.

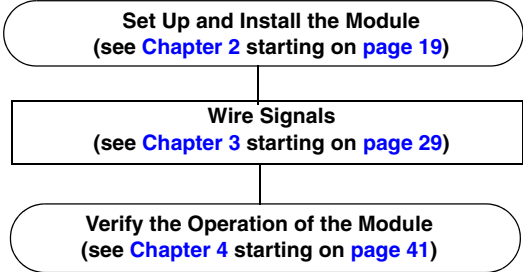

Figure 2: Getting Started Flow Diagram

Part 1: Getting Started



Setting Up and Installing the Module

| | |
|--|----|
| Unpacking..... | 21 |
| System Requirements | 22 |
| Attaching Modules to the Computer..... | 23 |
| Configuring the DT9850 Series Device Driver..... | 27 |

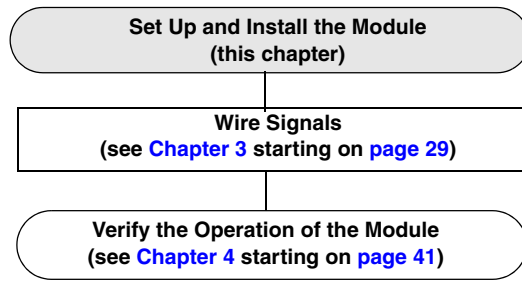

Unpacking

Open the shipping box and verify that the following items are present:

- DT9850 Series module
- USB cable
- Data Acquisition OMNI CD-ROM

If an item is missing or damaged, contact Data Translation. If you are in the United States, call the Customer Service Department at (508) 946-5100. An application engineer will guide you through the appropriate steps for replacing missing or damaged items. If you are located outside the United States, call your local distributor, listed on Data Translation's web site (www.mccdaq.com).

Note: The DT9850 Series module is factory-calibrated. If you decide that you want to recalibrate the analog output circuitry, refer to the instructions in [Chapter 8](#).

System Requirements

For reliable operation, ensure that your computer meets the following system requirements:

- Processor: Pentium 4/M or equivalent
- RAM: 1 GB
- Screen Resolution: 1024 x 768 pixels
- Operating System: Windows 8, Windows 7, Windows Vista (32- and 64-bit)
- Disk Space: 4 GB

Attaching Modules to the Computer

This section describes how to attach a DT9850 Series module to the host computer.

Notes: Most computers have several USB ports that allow direct connection to USB devices. If your application requires more DT9850 Series modules than you have USB ports for, you can expand the number of USB devices attached to a single USB port by using expansion hubs. For more information, refer to [page 25](#).

You can unplug a module, then plug it in again, if you wish, without causing damage. This process is called hot-swapping. Your application may take a few seconds to recognize a module once it is plugged back in.

The DT9850 Series module uses less than 500 mA; therefore, it does not require external power supply.

You must install the device driver before connecting your DT9850 Series module(s) to the host computer.

Connecting Directly to the USB Port

To connect a DT9850 Series module directly to a USB port on your computer, do the following:

1. Attach one end of the USB cable to the USB port on the module.
2. Attach the other end of the USB cable to one of the USB ports on the host computer, as shown in [Figure 3](#).

The operating system automatically detects the USB module and starts the Found New Hardware wizard.



Figure 3: Attaching the Module to the Host Computer

3. *For Windows Vista:*
 - a. Click **Locate and install driver software (recommended)**.
The popup message "Windows needs your permission to continue" appears.
 - b. Click **Continue**.
The Windows Security dialog box appears.
 - c. Click **Install this driver software anyway**.

Note: Windows 7 and Windows 8 find the device automatically.

4. Repeat these steps to attach another DT9850 Series module to the host computer, if desired.

Note: Once you have connected your module to the host computer, power is turned on to the DT9850 Series module when your application program opens the module. The LED on the module turns green to indicate that power is turned on.

Connecting to an Expansion Hub

Expansion hubs are powered by their own external power supply. The practical number of DT9850 Series modules that you can connect to a single USB port depends on the throughput you want to achieve.

To connect multiple DT9850 Series modules to an expansion hub, do the following:

1. Attach one end of the USB cable to the module and the other end of the USB cable to an expansion hub.
2. Connect the power supply for the expansion hub to an external power supply.
3. Connect the expansion hub to the USB port on the host computer using another USB cable.

The operating system automatically detects the USB module and starts the Found New Hardware wizard.

4. For Windows Vista:
 - a. Click **Locate and install driver software (recommended)**.
The popup message "Windows needs your permission to continue" appears.
 - b. Click **Continue**.
The Windows Security dialog box appears.
 - c. Click **Install this driver software anyway**.

Note: Windows 7 and Windows 8 find the device automatically.

5. Repeat these steps until you have attached the number of expansion hubs and modules that you require. Refer to [Figure 4](#).

The operating system automatically detects the USB devices as they are installed.

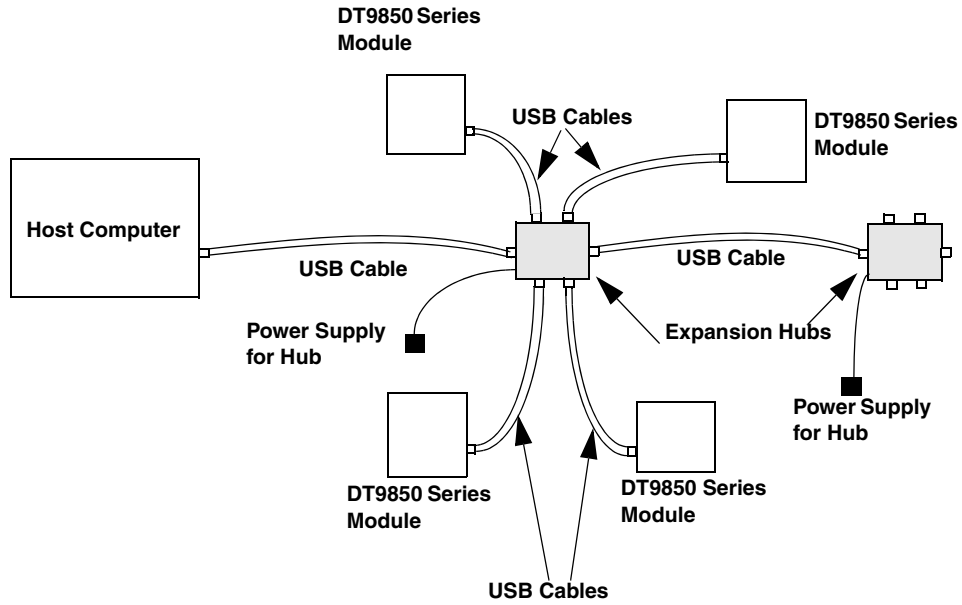

Figure 4: Attaching Multiple Modules Using Expansion Hubs

Note: Once you have connected your module to the host computer, power is turned on to the DT9850 Series module when your application program opens the module. The LED on the module turns green to indicate that power is turned on.

Configuring the DT9850 Series Device Driver

Note: In Windows 7, Windows 8, and Vista, you must have administrator privileges to run the Open Layers Control Panel. When you double-click the Open Layers Control Panel icon, you may see the Program Compatibility Assistant. If you do, select **Open the control panel using recommended settings**. You may also see a Windows message asking you if you want to run the Open Layers Control Panel as a "legacy CPL elevated." If you get this message, click **Yes**.

If you do not get this message and have trouble making changes in the Open Layers Control Panel, right click the DTOLCPL.CPL file and select **Run as administrator**. By default, this file is installed in the following location:

Windows 7, Windows 8, and Vista (32-bit)

C:\Windows\System32\Dtolcpl.cpl

Windows 7, Windows 8, and Vista (64-bit)

C:\Windows\SysWOW64\Dtolcpl.cpl

To configure the device driver for the DT9850 Series module, do the following:

1. If you have not already done so, power up the host computer and all peripherals.
2. From the Windows Start menu, select **Settings | Control Panel**.
3. From the Control Panel, double-click **Open Layers Control Panel**.
The Data Acquisition Control Panel dialog box appears.
4. Click the DT9850 Series module that you want to configure, and then click **Advanced**.
5. Click the **Digital Input Mask** tab to select the digital input lines that you want to enable for interrupt-on-change detection, where bit 0 corresponds to digital input line 0, bit 1 corresponds to digital input line 1, and so on. When any of the enabled digital lines changes state, the module reads the digital input value and generates an interrupt to alert your application about the change of state. Refer to [page 60](#) for more information on interrupt-on-change operations.
6. By default, power is continuously applied to the module even when applications that use the module are terminated; this ensures that all outputs remain constant. However, if you need to conserve power (especially when using a laptop), you may want to turn off power to the module when an application terminates its connection to it. Note, that in this case, the output values will float when the application terminates.

To turn power off to the module when an application terminates its connection to it, click the **High Power** tab, and click the **Power Off on termination** checkbox. High-power circuitry on the module will be powered down when you exit from applications that use the module. The module will remain off until you either run an application that uses the module or uncheck the **Power Off On Termination** checkbox.

7. Click **OK**.

8. If you want to rename the module, click **Edit Name**, enter a new name for the module, and then click **OK**. The name is used to identify the module in all subsequent applications.
9. Repeat steps 4 to 8 for the other DT9850 Series modules that you want to configure.
10. When you are finished configuring the modules, click **Close**.

Continue with the instructions on wiring in [Chapter 3 starting on page 29](#).



Wiring Signals

| | |
|--|----|
| Preparing to Wire Signals | 31 |
| Connecting an Analog Output Signal | 36 |
| Connecting Digital I/O Signals | 38 |
| Connecting Event Counting Signals | 40 |

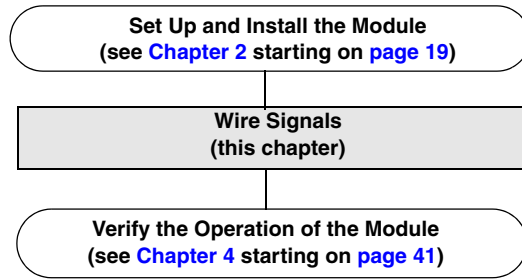

Preparing to Wire Signals

This section provides recommendations and information about wiring signals to the DT9850 Series module.

Wiring Recommendations

Keep the following recommendations in mind when wiring signals to a DT9850 Series module:

- Follow standard ESD procedures when wiring signals to the module.
- Separate power and signal lines by using physically different wiring paths or conduits.
- To avoid noise, do not locate the module and cabling next to sources that produce high electromagnetic fields, such as large electric motors, power lines, solenoids, and electric arcs, unless the signals are enclosed in a mumetal shield.
- Prevent electrostatic discharge to the I/O while the DT9850 Series module is operational.

Wiring Signals to the DT9850 Series Module

All DT9850 Series modules provide screw terminals for easy signal connections. The following tables list the screw terminal assignments for each DT9850 Series module:

- DT9853 module – [Table 2 on page 32](#)
- DT9853-M module – [Table 3 on page 33](#)
- DT9854 module – [Table 4 on page 34](#)
- DT9854-M module – [Table 5 on page 35](#)

Table 2: DT9853 Screw Terminal Assignments

| Screw Terminal | Signal | Screw Terminal | Signal |
|----------------|--------------------------------|----------------|-----------------------------------|
| 20 | +5 V Out | 40 | Digital Output, Line 7 |
| 19 | Digital I/O Termination Select | 39 | Digital Output, Line 6 |
| 18 | Analog Ground | 38 | Digital Output, Line 5 |
| 17 | Reserved | 37 | Digital Output, Line 4 |
| 16 | Reserved | 36 | Digital Output, Line 3 |
| 15 | Reserved | 35 | Digital Output, Line 2 |
| 14 | Reserved | 34 | Digital Output, Line 1 |
| 13 | Reserved | 33 | Digital Output, Line 0 |
| 12 | Reserved | 32 | Digital Ground |
| 11 | Reserved | 31 | Digital Input Line 7 |
| 10 | Reserved | 30 | Digital Input Line 6 ^a |
| 9 | Analog Ground | 29 | Digital Input Line 5 ^a |
| 8 | Reserved | 28 | Digital Input Line 4 ^a |
| 7 | Analog V_Output 3 | 27 | Digital Input Line 3 ^a |
| 6 | Reserved | 26 | Digital Input Line 2 ^a |
| 5 | Analog V_Output 2 | 25 | Digital Input Line 1 ^a |
| 4 | Reserved | 24 | Digital Input Line 0 ^a |
| 3 | Analog V_Output 1 | 23 | Digital Ground |
| 2 | Reserved | 22 | DAC_Sync |
| 1 | Analog V_Output 0 | 21 | Counter Input |

a. Supports interrupt-on-change.

Table 3: DT9853-M Screw Terminal Assignments

| Screw Terminal | Signal | Screw Terminal | Signal |
|----------------|--------------------------------|----------------|-----------------------------------|
| 20 | +5 V Out | 40 | Digital Output, Line 7 |
| 19 | Digital I/O Termination Select | 39 | Digital Output, Line 6 |
| 18 | Analog Ground | 38 | Digital Output, Line 5 |
| 17 | Reserved | 37 | Digital Output, Line 4 |
| 16 | Reserved | 36 | Digital Output, Line 3 |
| 15 | Reserved | 35 | Digital Output, Line 2 |
| 14 | Reserved | 34 | Digital Output, Line 1 |
| 13 | Reserved | 33 | Digital Output, Line 0 |
| 12 | Reserved | 32 | Digital Ground |
| 11 | Reserved | 31 | Digital Input Line 7 |
| 10 | Reserved | 30 | Digital Input Line 6 ^a |
| 9 | Analog Ground | 29 | Digital Input Line 5 ^a |
| 8 | Analog I_Output 3 | 28 | Digital Input Line 4 ^a |
| 7 | Analog V_Output 3 | 27 | Digital Input Line 3 ^a |
| 6 | Analog I_Output 2 | 26 | Digital Input Line 2 ^a |
| 5 | Analog V_Output 2 | 25 | Digital Input Line 1 ^a |
| 4 | Analog I_Output 1 | 24 | Digital Input Line 0 ^a |
| 3 | Analog V_Output 1 | 23 | Digital Ground |
| 2 | Analog I_Output 0 | 22 | DAC_Sync |
| 1 | Analog V_Output 0 | 21 | Counter Input |

a. Supports interrupt-on-change.

Table 4: DT9854 Screw Terminal Assignments

| Screw Terminal | Signal | Screw Terminal | Signal |
|----------------|--------------------------------|----------------|-----------------------------------|
| 20 | +5 V Out | 40 | Digital Output, Line 7 |
| 19 | Digital I/O Termination Select | 39 | Digital Output, Line 6 |
| 18 | Analog Ground | 38 | Digital Output, Line 5 |
| 17 | Reserved | 37 | Digital Output, Line 4 |
| 16 | Analog V_Output 7 | 36 | Digital Output, Line 3 |
| 15 | Reserved | 35 | Digital Output, Line 2 |
| 14 | Analog V_Output 6 | 34 | Digital Output, Line 1 |
| 13 | Reserved | 33 | Digital Output, Line 0 |
| 12 | Analog V_Output 5 | 32 | Digital Ground |
| 11 | Reserved | 31 | Digital Input Line 7 |
| 10 | Analog V_Output 4 | 30 | Digital Input Line 6 ^a |
| 9 | Analog Ground | 29 | Digital Input Line 5 ^a |
| 8 | Reserved | 28 | Digital Input Line 4 ^a |
| 7 | Analog V_Output 3 | 27 | Digital Input Line 3 ^a |
| 6 | Reserved | 26 | Digital Input Line 2 ^a |
| 5 | Analog V_Output 2 | 25 | Digital Input Line 1 ^a |
| 4 | Reserved | 24 | Digital Input Line 0 ^a |
| 3 | Analog V_Output 1 | 23 | Digital Ground |
| 2 | Reserved | 22 | DAC_Sync |
| 1 | Analog V_Output 0 | 21 | Counter Input |

a. Supports interrupt-on-change.

Table 5: DT9854-M Screw Terminal Assignments

| Screw Terminal | Signal | Screw Terminal | Signal |
|----------------|--------------------------------|----------------|-----------------------------------|
| 20 | +5 V Out | 40 | Digital Output, Line 7 |
| 19 | Digital I/O Termination Select | 39 | Digital Output, Line 6 |
| 18 | Analog Ground | 38 | Digital Output, Line 5 |
| 17 | Analog I_Output 7 | 37 | Digital Output, Line 4 |
| 16 | Analog V_Output 7 | 36 | Digital Output, Line 3 |
| 15 | Analog I_Output 6 | 35 | Digital Output, Line 2 |
| 14 | Analog V_Output 6 | 34 | Digital Output, Line 1 |
| 13 | Analog I_Output 5 | 33 | Digital Output, Line 0 |
| 12 | Analog V_Output 5 | 32 | Digital Ground |
| 11 | Analog I_Output 4 | 31 | Digital Input Line 7 |
| 10 | Analog V_Output 4 | 30 | Digital Input Line 6 ^a |
| 9 | Analog Ground | 29 | Digital Input Line 5 ^a |
| 8 | Analog I_Output 3 | 28 | Digital Input Line 4 ^a |
| 7 | Analog V_Output 3 | 27 | Digital Input Line 3 ^a |
| 6 | Analog I_Output 2 | 26 | Digital Input Line 2 ^a |
| 5 | Analog V_Output 2 | 25 | Digital Input Line 1 ^a |
| 4 | Analog I_Output 1 | 24 | Digital Input Line 0 ^a |
| 3 | Analog V_Output 1 | 23 | Digital Ground |
| 2 | Analog I_Output 0 | 22 | DAC_Sync |
| 1 | Analog V_Output 0 | 21 | Counter Input |

a. Supports interrupt-on-change.

Connecting an Analog Output Signal

This section describes how to connect a voltage or current output signal to a DT9850 Series module.

Connecting Voltage Output Signals

Figure 5 shows how to connect a voltage output signal, in this case Analog V_Output 0, to a DT9850 Series module.

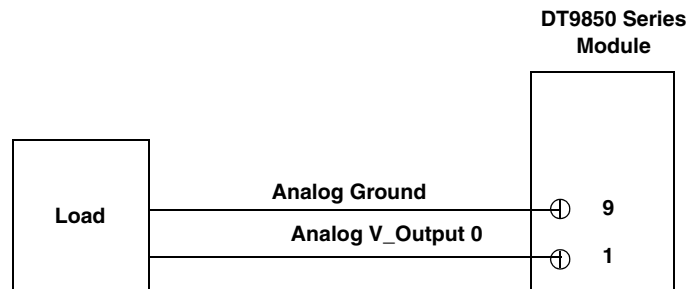

Figure 5: Connecting an Analog Voltage Output Signal to a DT9850 Series Module

Connecting Current Output Signals

To connect a current (I) output to the DT9853-M or DT9854-M module, note the following requirements:

- Use an excitation voltage supply between 8 VDC and 36 VDC to power the loop.
- Consider the drop across the load when selecting the excitation voltage supply. Typical applications use a 24 VDC excitation voltage supply.

To determine the maximum voltage at the load, use the following equation:

$$U_{load_max} = (\text{Compliance voltage} - 8 \text{ V}) / 0.02 \text{ A}$$

- The loop can use either a grounded external supply, where the load floats, or a grounded load, where the external supply floats.

Figure 6 shows an example of connecting a grounded excitation voltage supply (the load floats) to a current output channel of the DT9853-M or DT9854-M module. In this case, the output is connected to the Analog I_Output 0 signal.

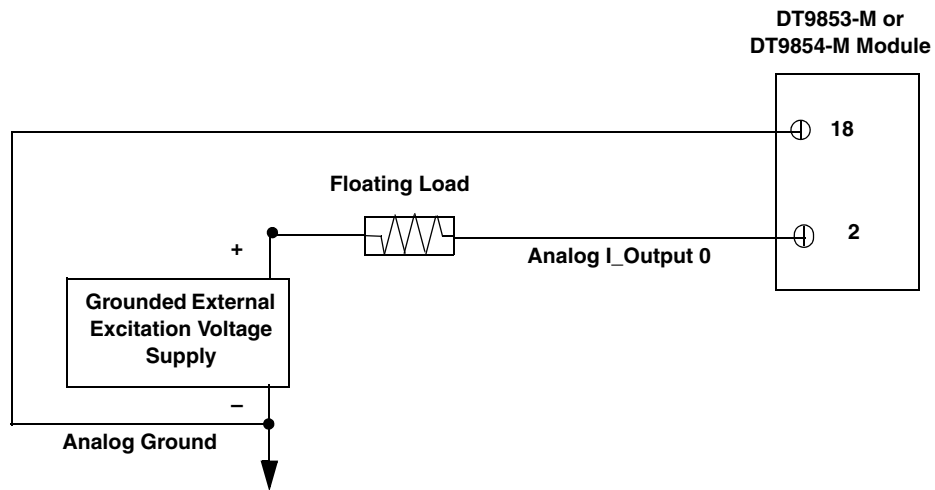

Figure 6: Connecting a Grounded External Excitation Voltage Supply (Floating Load) to a Current Output Signal of a DT9853-M or DT9854-M Module

Figure 7 shows an example of connecting a floating excitation voltage supply (the load is grounded) to a current output channel of the DT9853-M or DT9854-M module. In this case, the output is connected to the Analog I_Output 1 signal.

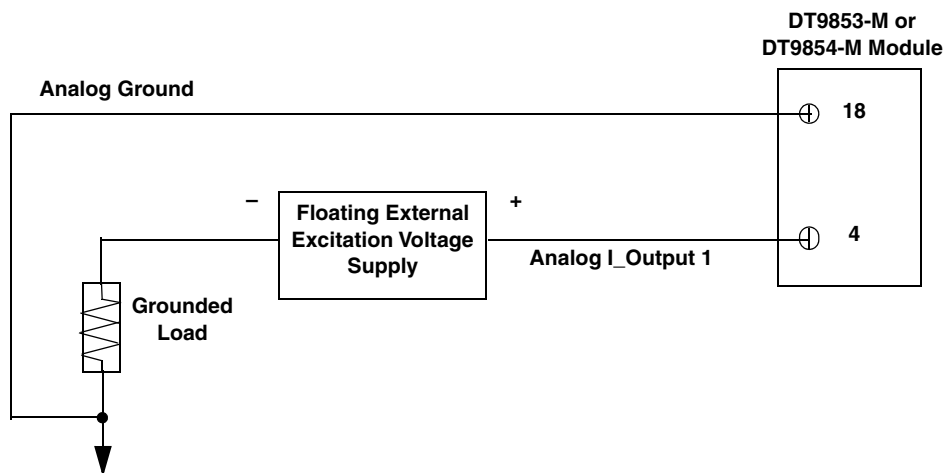

Figure 7: Connecting a Floating External Excitation Voltage Supply (Grounded Load) to a Current Output Signal of a DT9853-M or DT9854-M Module

Connecting Digital I/O Signals

This section describes how to configure the digital input signals for pull-up or pull-down, how to wire digital inputs, and how to wire digital outputs.

Configuring the State of the Digital Input Signals

By default, the digital input signals are floating when unwired. Using the Digital I/O Termination Select pin (TB1, pin 19), you can configure the digital input signals to be pulled up (high value) or to be pulled down (low value) when unwired. If you are using the interrupt-on-change feature, you must configure the state of the input lines or you will see unwanted transitions.

Figure 8 shows how to configure the digital I/O signals for pull-up; Figure 9 shows how to configure the digital I/O signals for pull-down.

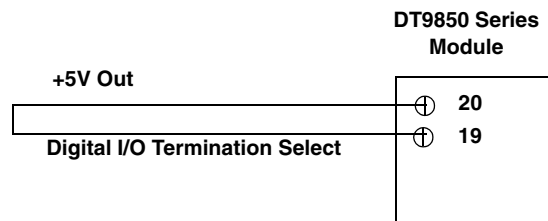
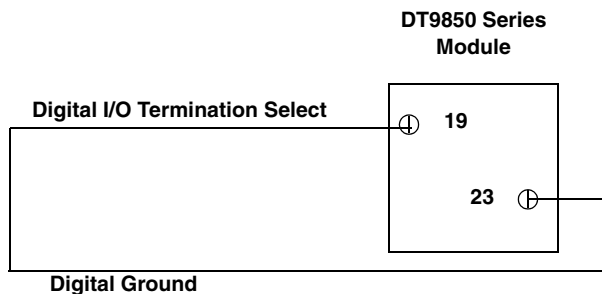

Figure 8: Configuring the Digital Input Signals for Pull-Up (High Value)



Note that you could connect pin 19 to any digital ground (pin 23 or 32) to pull down the Digital I/O Termination Select pin to 0 V.

Figure 9: Configuring the Digital Output Signals for Pull-Down (Low Value)

Connecting Digital Input Signals

Figure 10 shows how to connect a digital input signal (lines 1 and 3 of the digital input port, in this case) to a DT9850 Series module.

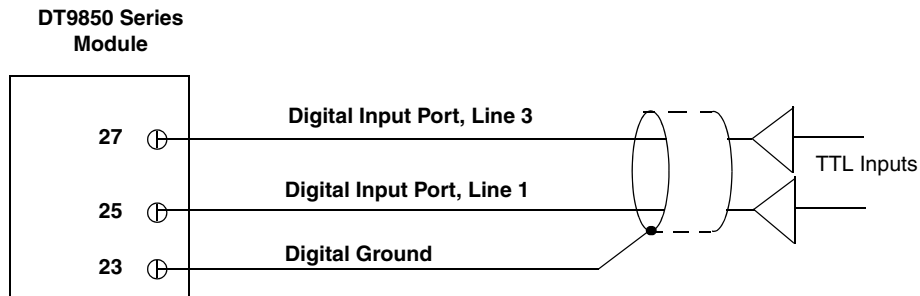

Figure 10: Connecting Digital Inputs to a DT9850 Series Module

Connecting Digital Output Signals

Figure 11 shows how to connect a digital output signal (line 0 of the digital output port, in this case) to a DT9850 Series module.

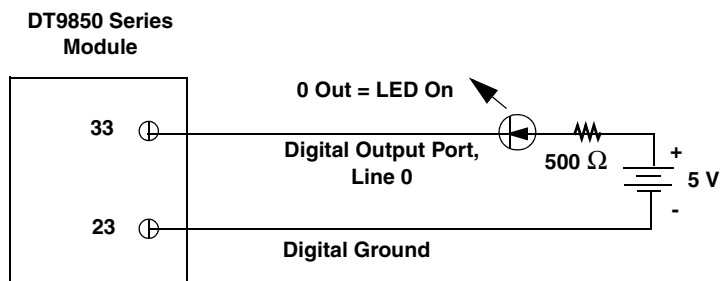

Figure 11: Connecting Digital Outputs to a DT9850 Series Module

Connecting Event Counting Signals

Figure 12 shows how to connect the Counter Input signal to the DT9850 Series module for an event counting application.

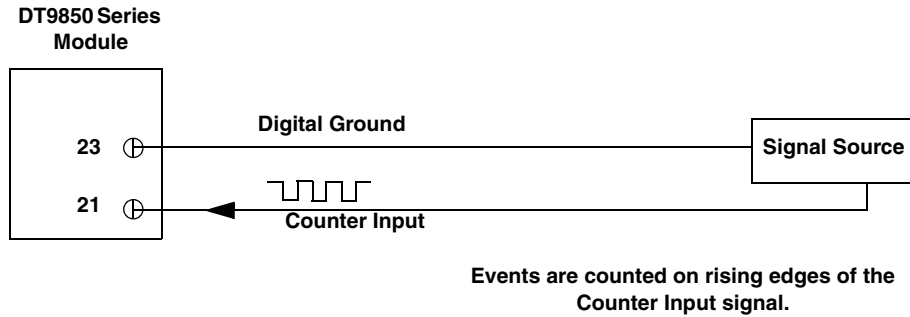
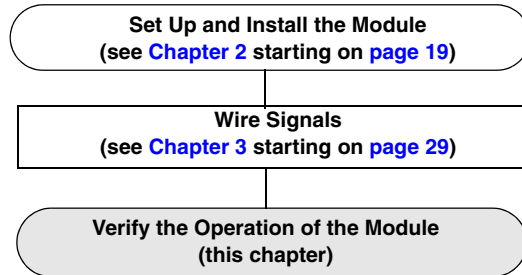

Figure 12: Connecting Signals for an Event Counting Application



Verifying the Operation of a Module

| | |
|--|----|
| Running the Quick DataAcq Application..... | 43 |
| Testing Single-Value Analog Output..... | 44 |
| Testing Continuous Analog Output | 44 |
| Testing Single-Value Digital Input..... | 46 |
| Testing Single-Value Digital Output | 47 |



You can verify the operation of a DT9850 Series module using the Quick DataAcq application. Quick DataAcq lets you do the following:

- Output a single value from the analog output channel
- Read a value from the digital input port
- Write a value to the digital output port

Running the Quick DataAcq Application

The Quick DataAcq application is installed automatically when you install the driver software.

To run the Quick DataAcq application, do the following:

1. If you have not already done so, power up your computer and any attached peripherals.
2. Click **Start** from the Task Bar.
3. Browse to **Programs | Data Translation, Inc | DT-Open Layers for Win32 | QuickDataAcq**.
The main menu appears.

Note: The Quick DataAcq application allows you to verify basic operations of the module; however, it may not support all of the module's features.

For information on each of the features provided, use the online help for the Quick DataAcq application by pressing F1 from any view or selecting the **Help** menu. If the system has trouble finding the help file, navigate to C:\Program Files\Data Translation\Win32\dtdataacq.hlp, where C: is the letter of your hard disk drive.

Testing Single-Value Analog Output

To verify that the module can output a single analog output value, do the following:

1. Connect an oscilloscope or voltmeter to analog output channel 0 on the module. Refer to [page 36](#) for an example of how to connect analog output signals.
2. In the QuickDataAcq application, choose **Single Analog Output** from the **Control** menu.
3. Select the appropriate DT9850 Series module from the **Board** list box.
4. In the **Channel** list box, select analog output channel 0.
5. In the **Range** list box, select the output range for analog output channel 0. The default is ± 10 V.
6. Enter an output value or use the slider to select a value to output from the analog output channel.
7. Click **Send** to output a single value from analog output channel 0.
The application displays the output value both on the slider and in the text box.

Testing Continuous Analog Output

To verify that the module can output a continuous analog signal, do the following:

1. Connect an oscilloscope or voltmeter to analog output channel 0 on the module. Refer to [page 36](#) for an example of how to connect analog output signals.
2. In the QuickDataAcq application, choose **Wave Generator** from the **Control** menu.
3. Select the appropriate DT9850 Series module from the **Board** list box.
4. In the **Waveform** area, select **Square** to output a square wave, **Sine** to output a sine wave, or **Triangle** to output a triangle waveform.
5. Change the **Peak Voltage** and **Wave Frequency** values, as desired, to construct the waveform to output.
6. Click **Start** to output the waveform from analog output channel 0.
The application displays the waveform in the Wave Generator window, and on the attached oscilloscope or voltmeter.

Testing Single-Value Digital Input

To verify that the board can read a single digital input value, do the following:

1. Connect a digital input to line 0 of the digital input port on the DT9850 Series module. Refer to [page 39](#) for an example of how to connect a digital input.
2. In the Quick DataAcq application, choose **Digital Input** from the **Acquisition** menu.
3. Select the appropriate DT9850 Series module from the **Board** list box.
4. Select the digital input port by clicking **Port B**.
5. Click **Get**.

The application displays the value of each digital input line in port B on the screen in both text and graphical form.

Testing Single-Value Digital Output

To verify that the module can output a single digital output value, do the following:

1. Connect a digital output to line 0 of the digital output port on the DT9850 Series module. Refer to [page 39](#) for an example of how to connect a digital output.
2. In the Quick DataAcq application, choose **Digital Output** from the **Control** menu.
3. Select the appropriate DT9850 Series module from the **Board** list box.
4. Select the digital output port by clicking **Port A**.
5. Click the appropriate bits to select the digital output lines to write to. Optionally, you can enter an output value in the Hex text box.
6. Click **Send**.

The application displays the value of each digital output line of digital port A on the screen in both text and graphical form.

Part 2: Using Your Module



Principles of Operation

| | |
|------------------------------|----|
| Analog Output Features | 53 |
| Digital I/O Features..... | 60 |
| Counter/Timer Features | 62 |

Figure 13 shows a block diagram of the DT9850 Series module.

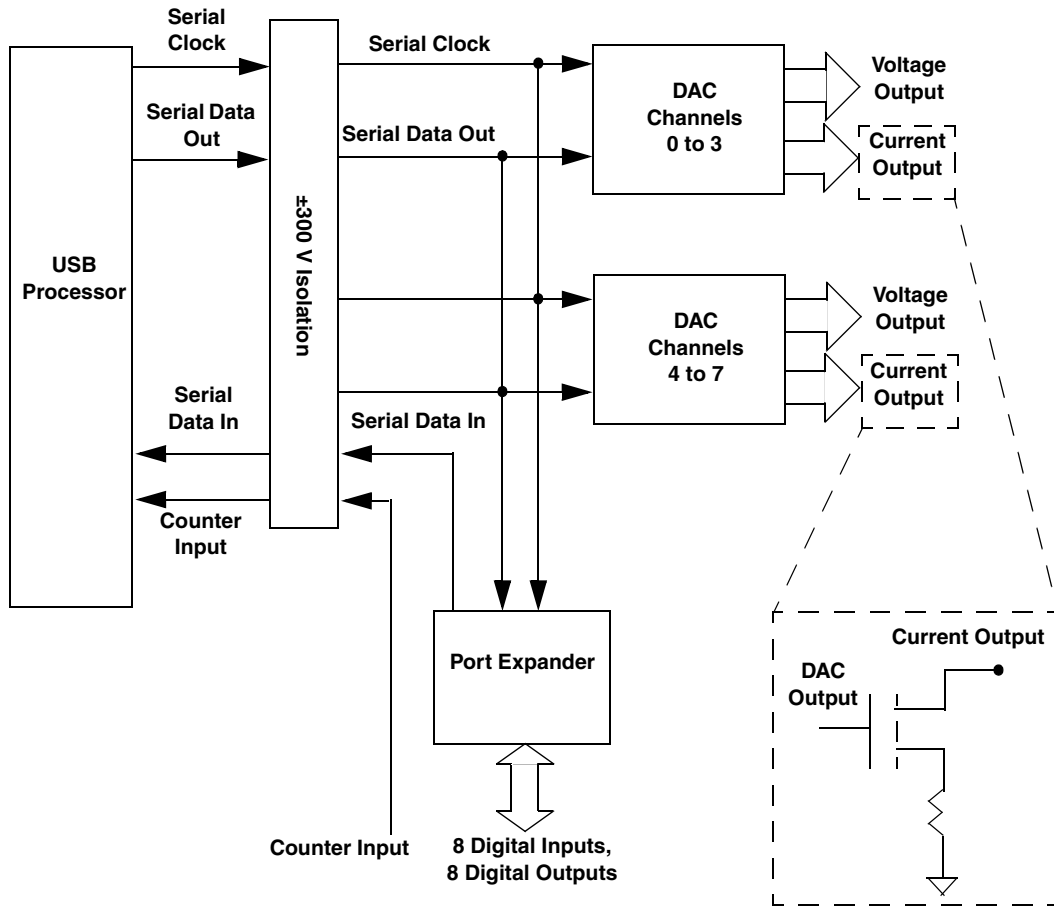

Figure 13: Block Diagram of the DT9850 Series Modules

Analog Output Features

This section describes the following features of analog output operations:

- Analog output channels, described below
- Ranges and gains, described below
- Resolution, described on [page 54](#)
- Operation mode, described on [page 55](#)
- Data format, described on [page 58](#)

Analog Output Channels

The DT9850 Series module supports either 4 or 8 analog output channels, depending on the module you purchased, through the analog output subsystem. The DT9853 and DT9853-M modules supports four analog output channels (numbered 0 to 3); the DT9854 and DT9854-M modules supports eight analog output channels (numbered 0 to 7). The DT9853 and DT9854 modules support voltage output only. The DT9853-M and DT9854-M modules support both voltage and current output. Use software to specify the channels to update.

Note: On the DT9853-M and DT9854-M modules, the D/A converter controls both a voltage and current output for each channel. Therefore, when you write to a value to a channel, both the current output signal and the voltage output signal of the associated channel are affected. How you wire the analog output channels determines how they are used. Refer to [page 39](#) for information on how to wire analog output signals to the module.

Within each analog output channel, the digital data is double-buffered to prevent spurious outputs, then output as an analog signal. All analog output channels power up to a value of 0 V \pm 10 mV. Resetting the module does not clear the values in the analog output channels.

Output Ranges and Gains

All DT9850 Series modules support an output range of \pm 10 V (default) or 0 to 10 V. Specify the range for the entire subsystem using software; you cannot specify unique ranges for individual channels. The gain for the D/A subsystem on the DT9850 Series modules is always 1 (the default value).

The voltage output value depends on the code that you write and the output range you selected. For example, if you specify a range of \pm 10 V, writing a code of 0000 to the output corresponds to -10 V; writing a code of FFFF to the output corresponds to +10 V. If, on the other hand, you specify a range of 0 to 10 V, writing a code of 0000 to the output corresponds to 0 V; writing a code of FFFF to the output corresponds to +10 V.

If you are using a DT9853-M or DT9854-M module and want to output current, ensure that you set the voltage range to 0 to 10 V.

The current output value then depends on the code that you write. For example, writing a code of 0000 to the output corresponds to 0 mA; writing a code of FFFF to the output corresponds to 20 mA.

Output Resolution

All DT9850 Series modules support an analog output resolution of 16 bits. The resolution cannot be programmed in software.

Output Clock (Continuous Mode Only)

When in continuous output mode, described on [page 57](#), you can update the analog output channels simultaneously with continuous values using the internal clock on the module.

Using software, specify the clock source for the analog output subsystem as internal and specify the frequency at which to update the analog output channels.

The output frequency of the module ranges between 61 Hz and 8 kHz.

The per channel output frequency is determined by dividing the frequency of the module by the number of enabled channels. For example, to update analog output channels at the maximum frequency of the module, divide 8 kHz by the number of enabled channels. [Table 6](#) lists the per channel output frequency that is supported at the maximum frequency of the module, based on the number of enabled channels.

Table 6: Per Channel Sampling Frequency at the Maximum Clock Frequency of the Module

| Number of Enabled Channels ^a | Maximum Sampling Frequency |
|---|----------------------------|
| 1 | 8000 Hz |
| 2 | 4000 Hz |
| 3 | 2666.666 Hz |
| 4 | 2000 Hz |
| 5 | 1600 Hz |
| 6 | 1333.333 Hz |
| 7 | 1142.857 Hz |
| 8 | 1000 Hz |

a. You enable an analog output channel by specifying it in the output channel list, described on [page 57](#).

Operation Modes

You can perform the following analog output operations on DT9850 Series modules:

- Update one analog output channel with a single value
- Simultaneously update analog output channels on one module with a single value
- Simultaneously update analog output channels on multiple modules with a single value
- Continuously update analog output channels on one module with a waveform

The following subsections describe how to configure the module for these operation types.

Updating a Single Analog Output Channel

To update the value of a single analog output channel, use software to perform a single value operation. You specify the analog output channel to update and the value to output.

When you start the operation, the analog output channel is updated immediately.

Single-value operations stop automatically when finished; you cannot stop a single-value operation.

Simultaneously Updating Analog Output Channels on One Module with a Single Value

To simultaneously update all the analog output channels of one module with a single value, use software to perform a single values operation. In a single values operation, you specify the analog output channels to update and the value to write to each analog output channel.

The module simultaneously updates the specified analog output channels with the values that you specified as soon as the single values command is issued.

Simultaneously Updating Analog Output Channels on Multiple Modules with a Single Value

You can simultaneously update the analog output channels of multiple modules by connecting the modules together through their DAC_Sync pins, as shown in [Figure 14](#).

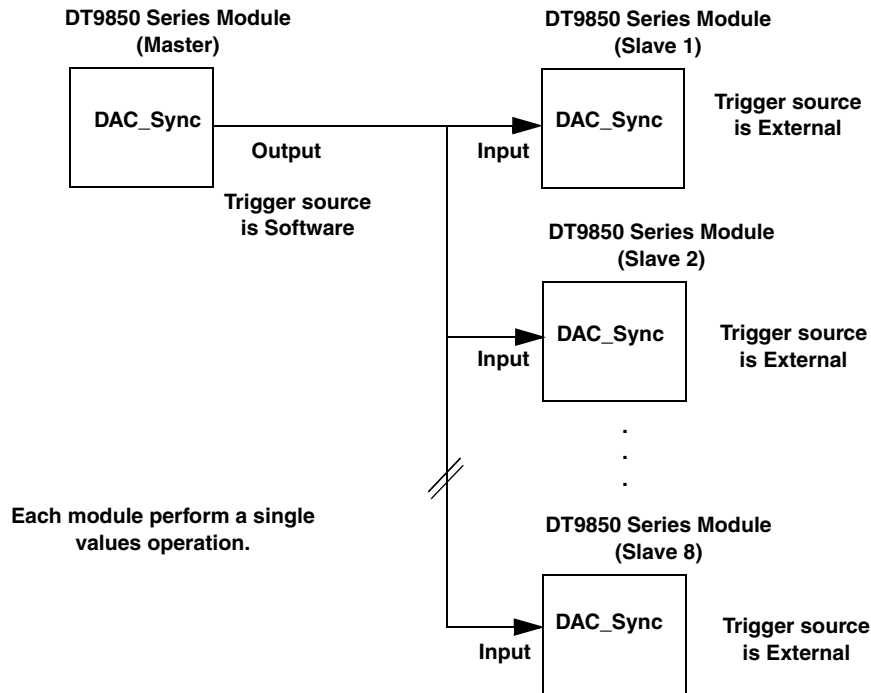

Figure 14: Simultaneously Updating the Analog Output Channels of Multiple Modules

In this scheme, you must configure the trigger source for one module (called the master module) as **Software**. Configure the trigger source for the other DT9850 Series modules (called slave modules) as an **External Positive TTL** trigger. In this configuration, the DAC_Sync signal is configured as an output on the master module and as an input on the slave modules.

To start the operation, issue a single values command on each of the slave modules. Then, issue a single values command on the master module. In a single values operation, you specify the output channels to update and the value to write to each analog output channel.

The master module automatically sends a signal from its DAC_Sync pin to the connected slave modules, allowing the analog output channels of all connected modules to be updated simultaneously with the values that you specified.

Note: If you are using continuous output mode, described on [page 57](#), the DAC_Sync pin cannot be used to synchronize multiple modules.

On power up and reset, the DAC_Sync pin is an input signal.

Continuously Updating Analog Output Channels on One Module with a Waveform

If you want to write a waveform to one or more analog output channels on one DT9850 Series module, use software to perform a continuously paced analog output operation. This is also known as streaming analog output data.

In a continuous analog output operation, you specify the analog output channels that you want to update in the output channel list. For example, if you want to update all eight analog output channels, specify the output channel list as follows: 0, 1, 2, 3, 4, 5, 6, 7.

You must also allocate one more buffers that contain the values to write to the selected analog output channels. For example, if your output channel list contains analog output channels 0 and 1, specify your buffer as follows: first value for analog output channel 0, first value for analog output channel 1, second value for analog output channel 0, second value for analog output channel 1, and so on.

The module updates the specified analog output channels with the waveform that you specified as soon as you start the continuous operation.

The values are output at the clock frequency that you specified (refer to [page 54](#) for more information on specifying the clock frequency). The operation repeats continuously until no more buffers are on the subsystem queue or you stop the operation.

Note: Make sure that the host computer transfers data to the analog output channels fast enough so that they do not empty completely; otherwise, an underrun error results.

To select continuously-paced analog output mode, use software to specify the following parameters:

- Set the dataflow mode to Continuous.
- Set WrapSingleBuffer to True to use a single buffer or to False to use multiple buffers. Refer to [page 58](#) for more information on buffers.
- Set the trigger source to Software trigger.

Note: When in continuous mode, the DAC_Sync pin is not used.

- Set the clock frequency based on the number of channels that you specified in the output channel list. Refer to [page 54](#) for more information on clock frequency.

To stop a continuously paced analog output operation, you can stop sending data to the module, letting the module stop when it runs out of data, or you can perform either an orderly stop or an abrupt stop using software. In an orderly stop, the module finishes outputting the data in the buffer, then stops; all subsequent triggers are ignored. In an abrupt stop, the module stops outputting samples immediately; all subsequent triggers are ignored.

Data Transfer

If you are using continuous output mode, you must allocate and fill either a single buffer or multiple buffers with the waveform that you want to output.

If you are using multiple buffers, data is written from the output buffers continuously; when no more buffers of data are available, the continuous output operation stops. This mode guarantees gap-free data.

If you use a single buffer, data is output continuously from the single buffer until you stop the operation.

A buffer done event is generated whenever the last value in a buffer is output. This allows you to fill the buffer or provide a new buffer, as needed.

Note: An underrun error can result if your buffer size is too small, if you do not allocate enough buffers, or if your clock rate is too fast.

Data Format

In software, you need to supply a code that corresponds to the analog output value you want the board to output. To convert a voltage to a code, use the following formulas:

$$\text{LSB} = \frac{\text{FSR}}{2^N}$$

$$\text{Code} = \frac{\text{Vout} - \text{Offset}}{\text{LSB}}$$

where,

- *LSB* is the least significant bit.
- *FSR* is the full-scale range. For the DT9850 Series, the full-scale analog output range is 10 for the unipolar range of 0 to 10 V, or 20 for the bipolar range of ± 10 V.
- *N* is the number of bits of the DAC, or 16 for these modules.
- *Code* is the raw count used by the software to represent the voltage.
- *Vout* is the analog output voltage.
- *Offset* is the minus full-scale value. The minus full-scale value is 0.0 V for the unipolar range or -10 V for the ± 10 V range.

For example, assume that you are using a DT9853 module with a bipolar output range of ± 10 V. The minus full-scale value is -10 V. If you want to output a voltage of 4.7 V, determine the code value as follows:

$$\text{LSB} = \frac{20}{65536} = 0.000305 \text{ V}$$

$$\text{Code} = \frac{4.7 \text{ V} - (-10 \text{ V})}{0.000305 \text{ V}}$$

$$\text{Code} = 48169 = \text{BC29h}$$

Note: If you are using a DT9853-M or DT9854-M module, the current value that is output depends on the range that you select and your current load. Refer to [page 53](#) for more information.

Digital I/O Features

This section describes the following digital I/O features of the DT9850 Series boards:

- Digital I/O lines
- Resolution
- Interrupts
- Operation modes

Digital I/O Lines

DT9850 Series modules support eight dedicated digital input lines through the digital input (DIN) and eight dedicated digital output lines through the (DOUT) subsystem.

By default, the digital input signals are floating when unwired. You can configure the state of the digital input signals to be pulled up (high value) or pulled down (low value) when they are unwired using the Digital I/O Termination Select pin (TB1, pin 19). Refer to [page 38](#) for wiring information.

For digital input operations, you can specify the digital input line to read using either a single-value or continuous digital input operation. For digital output operations, you can specify the digital output line to update using a single-value operation. Refer to [page 61](#) for more information on digital I/O operation modes.

On power up or reset, no digital data is output from the module.

Resolution

All DT9850 Series modules support a digital I/O resolution of 8 bits. This resolution is fixed and cannot be changed in software.

Interrupts

The DT9850 Series modules can generate an interrupt when digital input line 0 to 6 of the digital input port changes state. This feature is useful when you want to monitor critical signals or when you want to signal the host computer to transfer data to or from the module. You enable the interrupts on a line-by-line basis during when you configure the driver; refer to [page 27](#) for more information.

Note: To use the interrupt-on-change feature, you must configure the digital input lines for either pull up or pull down, or you will see noise on the input lines; refer to [page 38](#) for more information. Digital input line 7 of the digital input port cannot generate an interrupt.

Use software to determine which digital line changed state; refer to [page 61](#) for more information.

Operation Modes

DT9850 Series modules support the following digital I/O operation modes:

- **Single-value operations** – Use software to specify the DIN or DOUT subsystem, the resolution (8), and the gain (1) of the subsystem. Data is then read from or written to the appropriate digital I/O lines.

Single-value operations stop automatically when finished; you cannot stop a single-value operation.

Note: Although single-value operations are the simplest to use, they do not allow you to check the interrupt status; use continuous digital input mode, described next, to check the interrupt status.

- **Continuous digital input operations** – Allow you to read digital input values and check the interrupt status of the digital input port.

Use the Open Layers Control Panel applet to select any of the first seven digital input lines to perform interrupt-on-change operations; refer to [page 27](#) for information on enabling interrupts and to [page 38](#) for information on configuring the digital inputs for pull-up or pull-down.

Use software to specify DIN subsystem element 1, continuous mode, the resolution (8), and the trigger source (software).

Once the operation is configured and started, an event is generated when digital input line 0 to 6 of the digital input port changes state. Using software, you can then read the value of the digital input port and determine which digital input line changed state to cause the event.

Note: If you are using the DataAcq SDK to perform an interrupt-on-change operation, use the *lParam* parameter of the **oldDataSetWndHandle** or **oldDataSetNotificationProcedure** function to determine which digital input line changed state and the status of the digital input port when the interrupt occurred.

The low byte of the first word of *lParam* contains the state of the digital input subsystem, where bit 0 corresponds to digital input line 0 and bit 6 corresponds to digital input line 6.

The high byte of the first word of *lParam* contains the digital lines (bits) that changed state causing the interrupt to occur, where bit 8 corresponds to digital input line 0 and bit 14 corresponds to digital input line 6.

Counter/Timer Features

DT9850 Series modules provide one 32-bit counter/timer (counter/timer subsystem 0) that accepts a counter input signal with a frequency of up to 1 MHz. The module counts the number of rising edges that occur on the counter input signal. You can count a maximum of 4,294,967,296 events before the counter rolls over to 0 and starts counting again.

Using software, specify the counter/timer mode as event counting (count), the C/T clock source as external, and the gate type as software.

Make sure that the signals are wired appropriately. Refer to [page 40](#) for an example of connecting an event counting application.



Supported Device Driver Capabilities

| | |
|---|----|
| Data Flow and Operation Options..... | 65 |
| Buffering | 66 |
| Triggered Scan Mode | 66 |
| Data Encoding..... | 66 |
| Channels | 67 |
| Gain | 67 |
| Ranges | 68 |
| Resolution | 68 |
| Current and Resistance Support | 69 |
| Thermocouple, RTD, and Thermistor Support | 70 |
| IEPE Support..... | 71 |
| Bridge and Strain Gage Support | 71 |
| Start Triggers..... | 72 |
| Reference Triggers | 73 |
| Clocks..... | 73 |
| Counter/Timers | 74 |
| Tachometers..... | 75 |

The DT9850 Series Device Driver provides support for the analog input (A/D), analog output (D/A), and counter/timer (C/T) subsystems. For information on how to configure the device driver, refer to [page 27](#).

Table 7: DT9850 Series Subsystems

| DT9850 Series | A/D | D/A | DIN | DOUT | C/T | TACH | QUAD |
|----------------------------|-----|-----|-----|------|-----|------|------|
| Total Subsystems on Module | 0 | 1 | 1 | 1 | 1 | 0 | 0 |

The tables in this chapter summarize the features available for use with the DT-Open Layers for .NET Class Library and the DT9850 Series module. The DT-Open Layers for .NET Class Library provides properties that return support information for specified subsystem capabilities.

The first row in each table lists the subsystem types. The first column in each table lists all possible subsystem capabilities. A description of each capability is followed by the property used to describe that capability in the DT-Open Layers for .NET Class Library.

Note: The following tables include the capabilities that can be queried. However, some capabilities may not be supported by your device. Blank fields represent unsupported options.

For more information, refer to the description of these properties in the DT-Open Layers for .NET Class Library online help or *DT-Open Layers for .NET Class Library User's Manual*.

Data Flow and Operation Options

Table 8: Data Flow and Operation Options

| DT9850 Series | A/D | D/A | DIN | DOUT | C/T | TACH | QUAD |
|--|-----|------------------|------------------|------|-----|------|------|
| Single-Value Operation Support SupportsSingleValue | | Yes | Yes | Yes | Yes | | |
| Simultaneous Single-Value Output Operations SupportsSetSingleValues | | Yes ^a | | | | | |
| Continuous Operation Support SupportsContinuous | | Yes | Yes ^b | | Yes | | |
| Continuous Operation until Trigger SupportsContinuousPreTrigger | | | | | | | |
| Continuous Operation before & after Trigger SupportsContinuousPrePostTrigger | | | | | | | |
| Waveform Operations Using FIFO Only SupportsWaveformModeOnly | | | | | | | |
| Simultaneous Start List Support SupportsSimultaneousStart | | | | | | | |
| Supports Programmable Synchronization Modes SupportsSynchronization | | | | | | | |
| Synchronization Modes SynchronizationMode | | | | | | | |
| Interrupt Support SupportsInterruptOnChange | | | Yes ^b | | | | |
| FIFO Size, in Samples FifoSize | | 0 | | | | | |
| Muting and Unmuting the Output Voltage SupportsMute | | | | | | | |
| Auto-Calibrate Support SupportsAutoCalibrate | | | | | | | |

- a. You can also update multiple channels simultaneously with a single value by using the DAC_Sync pin. Refer to [page 55](#) for more information.
- b. The digital input port can operate in continuous digital input mode if you enabled interrupt usage for this port in the driver configuration dialog box (see [page 27](#)). The software generates an event when digital input line 0 to 6 of this port changes state. If you are using the DataAcq SDK, refer to [page 60](#) for more information about determining which digital input lines changed state.

Buffering

Table 9: Buffering Options

| DT9850 Series | A/D | D/A | DIN | DOUT | C/T | TACH | QUAD |
|---|-----|-----|-----|------|-----|------|------|
| Buffer Support SupportsBuffering | | Yes | | | | | |
| Single Buffer Wrap Mode Support SupportsWrapSingle | | Yes | | | | | |
| Inprocess Buffer Flush Support SupportsInProcessFlush | | | | | | | |

Triggered Scan Mode

Table 10: Triggered Scan Mode Options

| DT9850 Series | A/D | D/A | DIN | DOUT | C/T | TACH | QUAD |
|---|-----|-----|-----|------|-----|------|------|
| Triggered Scan Support SupportsTriggeredScan | | | | | | | |
| Maximum Number of CGL Scans per Trigger MaxMultiScanCount | 0 | 0 | 0 | 0 | 0 | | 0 |
| Maximum Retrigger Frequency MaxRetriggerFreq | 0 | 0 | 0 | 0 | 0 | | 0 |
| Minimum Retrigger Frequency MinRetriggerFreq | 0 | 0 | 0 | 0 | 0 | | 0 |

Data Encoding

Table 11: Data Encoding Options

| DT9850 Series | A/D | D/A | DIN | DOUT | C/T | TACH | QUAD |
|--|-----|-----|-----|------|-----|------|------|
| Binary Encoding Support SupportsBinaryEncoding | | Yes | Yes | Yes | Yes | | |
| Twos Complement Support SupportsTwosCompEncoding | | | | | | | |
| Returns Floating-Point Values ReturnsFloats | | | | | | | |

Channels

Table 12: Channel Options

| DT9850 Series | A/D | D/A | DIN | DOUT | C/T | TACH | QUAD |
|---|-----|---------------------|----------------|----------------|-----|------|------|
| Number of Channels NumberOfChannels | | 4 or 8 ^a | 1 ^b | 1 ^b | 1 | | |
| SE Support SupportsSingleEnded | | Yes | | | Yes | | |
| SE Channels MaxSingleEndedChannels | | 4 or 8 ^a | 0 | 0 | 1 | | |
| DI Support SupportsDifferential | | | Yes | Yes | | | |
| DI Channels MaxDifferentialChannels | | 0 | 1 | 1 | 0 | | |
| Maximum Channel-Gain List Depth CGLDepth | | 4 or 8 ^a | 0 | 0 | 0 | | |
| Simultaneous Sample-and-Hold Support SupportsSimultaneousSampleHold | | | | | | | |
| Channel-List Inhibit SupportsChannelListInhibit | | | | | | | |
| Support MultiSensor Inputs SupportsMultiSensor | | | | | | | |
| Bias Return Termination Resistor Support SupportsInputTermination | | | | | | | |

- a. The DT9853 and DT9853-M modules have four analog output channels and the DT9854 and DT9854-M modules have eight analog output channels.
- b. All modules have one dedicated 8-bit digital input port (port B) and one dedicated digital output port (port A).

Gain

Table 13: Gain Options

| DT9850 Series | A/D | D/A | DIN | DOUT | C/T | TACH | QUAD |
|--|-----|-----|-----|------|-----|------|------|
| Programmable Gain Support SupportsProgrammableGain | | | | | | | |
| Number of Gains NumberOfSupportedGains | | 1 | 1 | 1 | 0 | | |
| Gains Available SupportedGains | | 1 | 1 | 1 | | | |

Ranges

Table 14: Range Options

| DT9850 Series | A/D | D/A | DIN | DOUT | C/T | TACH | QUAD |
|---|-----|------------------------------------|-----|------|-----|------|------|
| Number of Voltage Ranges NumberOfRanges | 0 | 2 ^a | 0 | 0 | 0 | | |
| Available Ranges SupportedVoltageRanges | | ±10 V or 0 to 10 V ^b | | | | | |

- a. The DT9850 Series modules support an output range of ±10 V and 0 to 10 V. If you are using a DT9853-M or DT9854-M module and connect a current output signal to the module, the actual current that is output depends on the code that you write, the selected voltage range, and the load that you apply to the signal. Refer to [Chapter 5](#) for more information.
- b. If you are using a DT9853-M or DT9854-M module and want to output current, ensure that you set the voltage range to 0 to 10 V.

Resolution

Table 15: Resolution Options

| DT9850 Series | A/D | D/A | DIN | DOUT | C/T | TACH | QUAD |
|---|-----|-----|-----|------|-----|------|------|
| Software Programmable Resolution SupportsSoftwareResolution | | | | | | | |
| Number of Resolutions NumberOfResolutions | | 1 | 1 | 1 | 1 | | |
| Available Resolutions SupportedResolutions | | 16 | 8 | 8 | 32 | | |

Current and Resistance Support

Table 16: Current and Resistance Support Options

| DT9850 Series | A/D | D/A | DIN | DOUT | C/T | TACH | QUAD |
|--|-----|------------------|-----|------|-----|------|------|
| Current Support SupportsCurrent | | | | | | | |
| Current Output Support SupportsCurrentOutput | | Yes ^a | | | | | |
| Resistance Support SupportsResistance | | | | | | | |
| Software Programmable External Excitation Current Source for Resistance SupportsExternalExcitationCurrentSrc | | | | | | | |
| Software Programmable Internal Excitation Current Source SupportsInternalExcitationCurrentSrc | | | | | | | |
| Available Excitation Current Source Values SupportedExcitationCurrentValues | | | | | | | |

- a. The DT9850 Series modules support an output range of ± 10 V and 0 to 10 V. If you are using a DT9853-M or DT9854-M module and connect a current output signal to the module, the actual current that is output depends on the code that you write, the selected voltage range, and the load that you apply to the signal. Refer to [Chapter 5](#) for more information.

Thermocouple, RTD, and Thermistor Support

Table 17: Thermocouple, RTD, and Thermistor Support Options

| DT9850 Series | A/D | D/A | DIN | DOUT | C/T | TACH | QUAD |
|---|-----|-----|-----|------|-----|------|------|
| Thermocouple Support SupportsThermocouple | | | | | | | |
| RTD Support SupportsRTD | | | | | | | |
| Thermistor Support SupportsThermistor | | | | | | | |
| Voltage Converted to Temperature SupportsTemperatureDataInStream | | | | | | | |
| Supported Thermocouple Types ThermocoupleType | | | | | | | |
| Supports CJC Source Internally in Hardware SupportsCjcSourceInternal | | | | | | | |
| Supports CJC Channel SupportsCjcSourceChannel | | | | | | | |
| Available CJC Channels CjcChannel | | | | | | | |
| Supports Interleaved CJC Values in Data Stream SupportsInterleavedCjcTemperaturesInStream | | | | | | | |
| Supported RTD Types RTDType | | | | | | | |
| RTD R0 Coefficient RtdR0 | | | | | | | |
| Supports Data Filters SupportsTemperatureFilters | | | | | | | |
| Temperature Filter Types TemperatureFilterType | | | | | | | |

IEPE Support

Table 18: IEPE Support Options

| DT9850 Series | A/D | D/A | DIN | DOUT | C/T | TACH | QUAD |
|---|-----|-----|-----|------|-----|------|------|
| IEPE Support SupportsIEPE | Yes | | | | | | |
| Software Programmable AC Coupling SupportsACCoupling | | | | | | | |
| Software Programmable DC Coupling SupportsDCCoupling | | | | | | | |
| Software Programmable External Excitation Current Source SupportsExternalExcitationCurrentSrc | | | | | | | |
| Software Programmable Internal Excitation Current Source SupportsInternalExcitationCurrentSrc | | | | | | | |
| Available Excitation Current Source Values SupportedExcitationCurrentValues | | | | | | | |

Bridge and Strain Gage Support

Table 19: Bridge and Strain Gage Support Options

| DT9850 Series | A/D | D/A | DIN | DOUT | C/T | TACH | QUAD |
|---|-----|-----|-----|------|-----|------|------|
| Bridge Support SupportsBridge | | | | | | | |
| Supported Bridge Configurations BridgeConfiguration | | | | | | | |
| Strain Gage Support SupportsStrainGage | | | | | | | |
| Supported Strain Gage Bridge Configurations StrainGageBridgeConfiguration | | | | | | | |
| External Excitation Voltage SupportsExternalExcitationVoltage | | | | | | | |
| Internal Excitation Voltage SupportsInternalExcitationVoltage | | | | | | | |
| Shunt Calibration SupportsShuntCalibration | | | | | | | |
| Voltage Excitation Per Channel SupportedPerChannelVoltageExcitation | | | | | | | |
| Minimum Excitation Voltage MinExcitationVoltage | | | | | | | |
| Maximum Excitation Voltage MaxExcitationVoltage | | | | | | | |

Start Triggers

Table 20: Start Trigger Options

| DT9850 Series | A/D | D/A | DIN | DOUT | C/T | TACH | QUAD |
|---|-----|------------------|-----|------|-----|------|------|
| Software Trigger Support SupportsSoftwareTrigger | | Yes ^a | | | | | |
| External Positive TTL Trigger Support SupportsPosExternalTTLTrigger | | | | | | | |
| External Negative TTL Trigger Support SupportsNegExternalTTLTrigger | | | | | | | |
| External Positive TTL Trigger Support for Single-Value Operations SupportsSvPosExternalTTLTrigger | | Yes ^a | | | | | |
| External Negative TTL Trigger Support for Single-Value Operations SupportsSvNegExternalTTLTrigger | | | | | | | |
| Positive Threshold Trigger Support SupportsPosThresholdTrigger | | | | | | | |
| Negative Threshold Trigger Support SupportsNegThresholdTrigger | | | | | | | |
| Digital Event Trigger Support SupportsDigitalEventTrigger | | | | | | | |

a. Uses the DAC_Sync pin; refer to [page 55](#) for more information.

Reference Triggers

Table 21: Reference Trigger Options

| DT9850 Series | A/D | D/A | DIN | DOUT | C/T | TACH | QUAD |
|---|-----|-----|-----|------|-----|------|------|
| External Positive TTL Trigger Support SupportsPosExternalTTLTrigger | | | | | | | |
| External Negative TTL Trigger Support SupportsNegExternalTTLTrigger | | | | | | | |
| Positive Threshold Trigger Support SupportsPosThresholdTrigger | | | | | | | |
| Negative Threshold Trigger Support SupportsNegThresholdTrigger | | | | | | | |
| Digital Event Trigger Support SupportsDigitalEventTrigger | | | | | | | |
| Sync Bus Support SupportsSyncBusTrigger | | | | | | | |
| Analog Input Channels Supported for the Threshold Trigger SupportedThresholdTriggerChannels | | | | | | | |
| Post-Trigger Scan Count Support SupportsPostTriggerScanCount | | | | | | | |

Clocks

Table 22: Clock Options

| DT9850 Series | A/D | D/A | DIN | DOUT | C/T | TACH | QUAD |
|---|-----|--------------------|-----|------|-----|------|------|
| Internal Clock Support SupportsInternalClock | | Yes | | | | | |
| External Clock Support SupportsExternalClock | | | | | Yes | | |
| Simultaneous Input/Output on a Single Clock Signal SupportsSimultaneousClocking | | | | | | | |
| Base Clock Frequency BaseClockFrequency | | 4 MHz | 0 | 0 | 1.0 | | |
| Maximum Clock Divider MaxExtClockDivider | | 1.0 | 1.0 | 1.0 | 1.0 | | |
| Minimum Clock Divider MinExtClockDivider | | 1.0 | 1.0 | 1.0 | 1.0 | | |
| Maximum Frequency MaxFrequency | | 8 kHz ^a | 0 | 0 | 0 | | |
| Minimum Frequency MinFrequency | | 61 Hz ^a | 0 | 0 | 0 | | |

- a. To determine the per channel output frequency, divide the frequency of the module by the number of enabled output channels.

Counter/Timers

Table 23: Counter/Timer Options

| DT9850 Series | A/D | D/A | DIN | DOUT | C/T | TACH | QUAD |
|--|-----|-----|-----|------|-----|------|------|
| Cascading Support SupportsCascading | | | | | | | |
| Event Count Mode Support SupportsCount | | | | | Yes | | |
| Generate Rate Mode Support SupportsRateGenerate | | | | | | | |
| One-Shot Mode Support SupportsOneShot | | | | | | | |
| Repetitive One-Shot Mode Support SupportsOneShotRepeat | | | | | | | |
| Up/Down Counting Mode Support SupportsUpDown | | | | | | | |
| Edge-to-Edge Measurement Mode Support SupportsMeasure | | | | | | | |
| Continuous Edge-to-Edge Measurement Mode Support SupportsContinuousMeasure | | | | | | | |
| High to Low Output Pulse Support SupportsHighToLowPulse | | | | | | | |
| Low to High Output Pulse Support SupportsLowToHighPulse | | | | | | | |
| Variable Pulse Width Support SupportsVariablePulseWidth | | | | | | | |
| None (internal) Gate Type Support SupportsGateNone | | | | | Yes | | |
| High Level Gate Type Support SupportsGateHighLevel | | | | | | | |
| Low Level Gate Type Support SupportsGateLowLevel | | | | | | | |
| High Edge Gate Type Support SupportsGateHighEdge | | | | | | | |
| Low Edge Gate Type Support SupportsGateLowEdge | | | | | | | |
| Level Change Gate Type Support SupportsGateLevel | | | | | | | |
| Clock-Falling Edge Type SupportsClockFalling | | | | | | | |
| Clock-Rising Edge Type SupportsClockRising | | | | | | | |
| Gate-Falling Edge Type SupportsGateFalling | | | | | | | |
| Gate-Rising Edge Type SupportsGateRising | | | | | | | |
| Interrupt-Driven Operations SupportsInterrupt | | | | | | | |

Tachometers

Table 24: Tachometer Options

| DT9850 Series | A/D | D/A | DIN | DOUT | C/T | TACH | QUAD |
|--|------------|------------|------------|-------------|------------|-------------|-------------|
| Tachometer Falling Edges SupportsFallingEdge | | | | | | | |
| Tachometer Rising Edges SupportsRisingEdge | | | | | | | |
| Tachometer Stale Data Flag SupportsStaleDataFlag | | | | | | | |



Troubleshooting

| | |
|--|----|
| General Checklist | 78 |
| Technical Support | 80 |
| If Your Module Needs Factory Service | 81 |

General Checklist

Should you experience problems using a DT9850 Series module, do the following:

1. Read all the documentation provided for your product, including any “Read This First” information.
2. Check the OMNI CD for any README files and ensure that you have used the latest installation and configuration information available.
3. Check that your system meets the requirements stated on [page 22](#).
4. Check that you have installed your hardware properly using the instructions in [Chapter 2](#).
5. Check that you have installed and configured the device driver properly using the instructions in [Chapter 2](#).
6. Check that you have wired your signals properly using the instructions in [Chapter 3](#).
7. Search the DT Knowledgebase in the Support section of the Data Translation web site (at www.mccdaq.com) for an answer to your problem.

If you still experience problems, try using the information in [Table 25](#) to isolate and solve the problem. If you cannot identify the problem, refer to [page 80](#).

Table 25: Troubleshooting Problems

| Symptom | Possible Cause | Possible Solution |
|--------------------------|--|--|
| Module is not recognized | You plugged the module into your computer before installing the device driver. | From the Control Panel > System > Hardware > Device Manager, uninstall any unknown devices (showing a yellow question mark). Then, run the setup program on your OMNI CD to install the USB device drivers, and reconnect your USB module to the computer. |
| Module does not respond. | The module configuration is incorrect. | Check the configuration of your device driver; see the instructions in Chapter 2 . |
| | The module is damaged. | Contact Data Translation for technical support; refer to page 80 . |
| Intermittent operation. | Loose connections or vibrations exist. | Check your wiring and tighten any loose connections or cushion vibration sources; see the instructions in Chapter 3 . |
| | The module is overheating. | Check environmental and ambient temperature; consult the module's specifications on page 93 of this manual and the documentation provided by your computer manufacturer for more information. |
| | Electrical noise exists. | Check your wiring and either provide better shielding or reroute unshielded wiring; see the instructions in Chapter 3 . |

Table 25: Troubleshooting Problems (cont.)

| Symptom | Possible Cause | Possible Solution |
|--------------------------------|--|--|
| Device failure error reported. | The DT9850 Series module cannot communicate with the Microsoft bus driver or a problem with the bus driver exists. | Check your cabling and wiring and tighten any loose connections; see the instructions in Chapter 3 . |
| | The DT9850 Series module was removed while an operation was being performed. | Ensure that your DT9850 Series module is properly connected; see the instructions in Chapter 2 . |
| Data appears to be invalid. | An open connection exists. | Check your wiring and fix any open connections; see the instructions in Chapter 3 . |
| | The DT9850 Series module is out of calibration. | DT9850 Series modules are calibrated at the factory. If you want to readjust the calibration of the analog output circuitry, refer to Chapter 8 . |
| USB 2.0 is not recognized. | Your operating system does not have the appropriate Service Pack installed. | Ensure that you load the appropriate Windows Service Pack. If you are unsure of whether you are using USB 2.0 or USB 1.1, run the Open Layers Control Panel applet, described in Chapter 2 . |
| | Standby mode is enabled on your PC. | For some PCs, you may need to disable standby mode on your system for proper USB 2.0 operation. Consult Microsoft for more information. |

Technical Support

If you have difficulty using a DT9850 Series module, Data Translation's Technical Support Department is available to provide technical assistance.

To request technical support, go to our web site at <http://www.mccdaq.com> and click on the Support link.

When requesting technical support, be prepared to provide the following information:

- Your product serial number
- The hardware/software product you need help on
- The version of the OMNI CD you are using
- Your contract number, if applicable

If you are located outside the USA, contact your local distributor; see our web site (www.mccdaq.com) for the name and telephone number of your nearest distributor.

If Your Module Needs Factory Service

Most hardware models can be functionally tested, evaluated for repairs (if needed), and calibrated to factory specifications. An RMA # must be obtained from Application Engineering in advance of sending any product back to Measurement Computing. Customers outside the USA must contact their local distributor for a return procedure. Calibration certificates for most analog models can be obtained for a fee (certificate must be requested at time of RMA # assignment).



Calibration

| | |
|---|----|
| Using the Calibration Utility | 84 |
| Calibrating the Analog Output Subsystem | 85 |

Using the Calibration Utility

DT9850 Series modules are calibrated at the factory and should not require calibration for initial use. We recommend that you check and, if necessary, readjust the calibration of the analog output circuitry on the DT9850 Series modules every six months using the DT9850 Series Calibration Utility and a precision digital multimeter (DMM).

Note: Ensure that you installed the DT9850 Series Device Driver prior to using the DT9850 Series Calibration Utility.

Start the DT9850 Series Calibration Utility as follows:

1. Make sure that one or more DT9850 Series modules are attached to your computer.
2. Attach a precision DMM to the DT9850 Series module's outputs.
3. Click **Start** from the Task Bar, and then select **Programs | Data Translation, Inc | Calibration | DT9850 Series Calibration Utility**.
The DT9850 Calibration utility appears.
4. Select the module to calibrate from the **Board** drop-down list box.

Once the DT9850 Series Calibration Utility is running, you can calibrate the analog output circuitry of the DT9850 Series module, described on [page 85](#).

Calibrating the Analog Output Subsystem

Once the DT9850 Series Calibration Utility is running and you have connected a precision digital multimeter (DMM) to the module's outputs, do the following to calibrate the analog output subsystem:

1. If you have not already done so, select the name of the module to calibrate from the **Board** drop-down list box. The utility lists only DT9850 Series modules.
2. Select one of the **Output Range** buttons: **-10V to 10V** (bipolar) or **0V to 10V** (unipolar).

Note: If you are solely interested in using current output, calibrate the unipolar voltage range.

3. Select **DA channel 0**. (The list box reflects the number of channels available on the module.)
4. Select the **Offset calibration** button.
5. Click the increment or decrement arrows in the adjustment box until the measured voltage on the connected DMM is 0 V (within 0.0005 V).
6. Select the **Gain Calibration** button.
7. Click the increment or decrement arrows in the adjustment box until the measured voltage on the connected DMM is 0 V (within 0.0005 V).
8. Select the next **DA channel** to calibrate.
9. Repeat steps 4 to 7 until all the DACs on the module are calibrated.
10. Click **Done** when you are finished calibrating the analog output circuitry.



Specifications

| | |
|---|----|
| Analog Output Specifications | 88 |
| Digital I/O Specifications | 90 |
| Counter/Timer Specifications | 91 |
| DAC_Sync Trigger Specifications | 92 |
| Power, Physical, and Environmental Specifications | 93 |
| Regulatory Specifications | 94 |

Analog Output Specifications

Table 26 lists the analog output specifications for the DT9850 Series modules.

Table 26: Analog Output Specifications

| Description | Feature | Specifications |
|--------------------------------------|---|---|
| General DAC Specifications | Number of analog output channels DT9853 and DT9853-M: DT9854 and DT9854-M: | 4 8 |
| | Resolution | 16 bits |
| | Data encoding (input) | Offset binary |
| | Nonlinearity (integral) | ±4 LSB typical |
| | Differential linearity | ±1 LSB (monotonic) |
| | Throughput (full scale) Single value: | 1 kHz update rate for a single channel, typical (system dependent) |
| | Continuous: | Up to 8 kHz for a single channel or 1 kHz for eight channels (see page 54) for more information) |
| Isolation to the host computer | ±300 V | |
| Voltage Output Specifications | Output range (@3.5 mA, 2.8 kΩ) | ±10 V, 0 to 10 V (software configurable) |
| | Output transient ±10 V to (0 to 10 V) or (0 to 10 V) to ±10 V range selection: | Duration: 5 μs typical; Amplitude: 5 V p-p typical |
| | Host is reset, powered on, suspended, or a reset command is issued to the device: | Duration: 50 ms typical; Amplitude: 0.5 V peak typical |
| | Initial power on: | Duration: 50 ms typical; Amplitude: 0.5 V peak typical |
| | Zero error ^a 0 to 10 V range: -10 V to +10 V range: | 0 V ±0.5 mV 0 V ±2.0 mV |
| | Gain error ^a | ±0.005% of full-scale range |
| | Relative accuracy 0 to 10 V range: -10 V to +10 V range: | ±0.6 mV ±1.2 mV |
| | Output impedance | 0.3 Ω typical |
| | Output coupling | DC |
| | Capacitive drive capability | 0.001 μF minimum (no oscillations) |
| Protection | Short Circuit to Analog Common | |

Table 26: Analog Output Specifications (cont.)

| Description | Feature | Specifications |
|---|---|--|
| Voltage Output Specifications (con.) | Power-on voltage | -50 mV ±10 mV |
| | Settling time to 0.01% of FSR | 10 μs, 20 V step |
| | Slew rate | 2 V/μs |
| Current Output Specifications | Current output (DT9853 and DT9854) | ±3.5 mA maximum (10 V/2.8 kΩ) |
| | Current output sink (DT9853-M and DT9854-M) | 0 to 20 mA |
| | Compliance voltage range | +8 VDC to +36 VDC ^b |
| | Absolute accuracy Resistive load = 100 Ω: | ±0.05% of full-scale range |
| | Leakage current (all 0s written to current output channels) | 100 nA maximum (for each current output channel) |

- a. After the unit has been calibrated at the factory.
- b. Use the following equation to determine the maximum voltage to use at the load:
- $$U_{load_max} = (\text{Compliance voltage} - 8 \text{ V}) / 0.02 \text{ A}$$

Digital I/O Specifications

Table 27 lists the digital input and digital output specifications for the DT9850 Series modules.

Table 27: Digital Input and Digital Output Specifications

| Feature | Specifications |
|---|--|
| Digital logic type | CMOS |
| Number of lines | 8 digital inputs (port B); 8 digital outputs (port A) |
| Digital I/O transfer rate | Up to 1 kHz (system dependent) |
| Power on and reset state | Digital input |
| Pull-up/pull-down configuration | User-configurable on inputs ^a ; By default, all input pins floating |
| Digital input loading | TTL (default) 47 k Ω (pull-up/pull-down configuration) |
| Inputs Input type: Input load: High-level input voltage: Low-level input voltage: Interrupt-on-change: | Level sensitive Schmitt trigger 3.5 V minimum 1.5 V maximum Digital input lines 0 to 6 |
| Outputs Output driver: Output driver high voltage: Output driver low voltage: | Push-pull logic 4.3 V minimum (IOH = -2 mA); 0.6 V maximum (IOL = 10 mA) |

- a. For pull-up, connect the Digital I/O Termination Select pin to the +5 V Out pin. For pull-down, connect the Digital I/O Termination select pin to the Digital Ground pin.

Counter/Timer Specifications

Table 28 lists the specifications for the C/T subsystem.

Table 28: C/T Subsystem Specification

| Feature | Specifications |
|--------------------------------------|--|
| Number of counter/timer channels | 1 |
| Resolution | 32 |
| Counter mode | Event counting |
| Input type | TTL, rising-edge trigger |
| Maximum input frequency | 1 MHz |
| Minimum pulse width High: Low: | 500 ns 500 ns |
| Schmidt trigger hysteresis | 20 mV to 100 mV |
| Input leakage current | $\pm 1.0 \mu\text{A}$ typical |
| Input high voltage | 4.0 V minimum, 5.5 V absolute maximum |
| Input low voltage | 1.0 V maximum, -0.5 V absolute minimum |

DAC_Sync Trigger Specifications

Table 29 lists the specifications for the DAC_Sync trigger signal.

Table 29: DAC_Sync Trigger Specification

| Feature | Specifications |
|--|---|
| Power on and reset state | Input |
| Termination | Internal 100 k Ω pull-down |
| Software-selectable direction Input ^a : Output ^b : | Receives DAC_Sync signal from external source Outputs internal DAC_Sync signal |
| Clock pulse width Input: Output: | 1 μ s minimum 5 μ s minimum |
| Input leakage current | ± 1.0 μ A typical |
| Input high voltage | 4.0 V minimum, 5.5 V absolute maximum |
| Input low voltage | 1.0 V minimum, -0.5 V absolute minimum |
| Output high voltage ^c IOH = -2.5 mA: No load: | 3.3 V minimum 3.8 V minimum |
| Output low voltage IOH = 2.5 mA: No load: | 1.1 V maximum 0.6 V maximum |

- a. When you configure the trigger source for the module as external, the DAC_Sync signal is configured as an input. When a low-to-high transition is detected on the DAC_Sync pin, the module simultaneously updates its analog output channels.
- b. When you configure the trigger source for the module as software (the default configuration), the DAC_Sync signal is configured as an output. When you start an operation (using a software command), the module outputs a signal on the DAC_Sync pin.
- c. DAC_Sync is a Schmitt trigger input is over-current protected with a 200 Ω series resistor.

Power, Physical, and Environmental Specifications

Table 30 lists the power, physical, and environmental specifications for the DT9850 Series modules.

Table 30: Power, Physical, and Environmental Specifications

| Feature | Specifications |
|---|---|
| Power +5 V: +5 V Output: | ±0.5 V @ 500 mA maximum 10 mA (isolated) |
| Physical Dimensions: Weight: | 100 mm x 100 mm 65.79 g |
| Environmental Operating temperature range DT9853 and DT9854: DT9853-M and DT9854-M: Storage temperature range: Relative humidity: Altitude: | 0° C to 70° C 0° C to 50° C –40° C to 85° C to 90%, noncondensing up to 10,000 feet |

Regulatory Specifications

DT9850 Series modules are CE-compliant. [Table 31](#) lists the regulatory specifications for the DT9850 Series modules.

Table 31: Regulatory Specifications

| Feature | Specifications |
|--------------------------------|--|
| Emissions (EMI) | FCC Part 15, Class A EN55011:2007 (Based on CISPR-11, 2003/A2, 2006) |
| Immunity | EN61326-1:2006 Electrical Equipment for Measurement, Control, and Laboratory Use <u>EMC Requirements</u> EN61000-4-2:2009 Electrostatic Discharge (ESD) 4 kV contact discharge, 8 kV air discharge, 4 kV horizontal and vertical coupling planes EN61000-4-3:2006 Radiated electromagnetic fields, 3 V/m, 80 to 1000 MHz; 3 V/m, 1.4 GHz to 2 GHz; 1 V/m, 2 GHz to 2.7 GHz EN61000-4-4:2004 Electrical Fast Transient/Burst (EFT) 1 kV on data cables EN61000-4-6:2009 Conducted immunity requirements, 3 Vrms on data cables 150 kHz to 80 MHz |
| RoHS (EU Directive 2002/95/EG) | Compliant (as of July 1st, 2006) |



Screw Terminal Assignments

| | |
|---|-----|
| DT9853 Screw Terminal Assignments | 96 |
| DT9853-M Screw Terminal Assignments | 97 |
| DT9854 Screw Terminal Assignments | 98 |
| DT9854-M Screw Terminal Assignments | 99 |
| LED Status Indicators | 100 |

DT9853 Screw Terminal Assignments

Table 32 lists the screw terminal assignments for the DT9853.

Table 32: DT9853 Screw Terminal Assignments

| Screw Terminal | Signal | Screw Terminal | Signal |
|----------------|--------------------------------|----------------|-----------------------------------|
| 20 | +5 V Out | 40 | Digital Output Line 7 |
| 19 | Digital I/O Termination Select | 39 | Digital Output Line 6 |
| 18 | Analog Ground | 38 | Digital Output Line 5 |
| 17 | Reserved | 37 | Digital Output Line 4 |
| 16 | Reserved | 36 | Digital Output Line 3 |
| 15 | Reserved | 35 | Digital Output Line 2 |
| 14 | Reserved | 34 | Digital Output Line 1 |
| 13 | Reserved | 33 | Digital Output Line 0 |
| 12 | Reserved | 32 | Digital Ground |
| 11 | Reserved | 31 | Digital Input Line 7 |
| 10 | Reserved | 30 | Digital Input Line 6 ^a |
| 9 | Analog Ground | 29 | Digital Input Line 5 ^a |
| 8 | Reserved | 28 | Digital Input Line 4 ^a |
| 7 | Analog V_Output 3 | 27 | Digital Input Line 3 ^a |
| 6 | Reserved | 26 | Digital Input Line 2 ^a |
| 5 | Analog V_Output 2 | 25 | Digital Input Line 1 ^a |
| 4 | Reserved | 24 | Digital Input Line 0 ^a |
| 3 | Analog V_Output 1 | 23 | Digital Ground |
| 2 | Reserved | 22 | DAC_Sync |
| 1 | Analog V_Output 0 | 21 | Counter Input |

a. Supports interrupt-on-change.

DT9853-M Screw Terminal Assignments

Table 33 lists the screw terminal assignments for the DT9853-M.

Table 33: DT9853-M Screw Terminal Assignments

| Screw Terminal | Signal | Screw Terminal | Signal |
|----------------|--------------------------------|----------------|-----------------------------------|
| 20 | +5 V Out | 40 | Digital Output Line 7 |
| 19 | Digital I/O Termination Select | 39 | Digital Output Line 6 |
| 18 | Analog Ground | 38 | Digital Output Line 5 |
| 17 | Reserved | 37 | Digital Output Line 4 |
| 16 | Reserved | 36 | Digital Output Line 3 |
| 15 | Reserved | 35 | Digital Output Line 2 |
| 14 | Reserved | 34 | Digital Output Line 1 |
| 13 | Reserved | 33 | Digital Output Line 0 |
| 12 | Reserved | 32 | Digital Ground |
| 11 | Reserved | 31 | Digital Input Line 7 |
| 10 | Reserved | 30 | Digital Input Line 6 ^a |
| 9 | Analog Ground | 29 | Digital Input Line 5 ^a |
| 8 | Analog I_Output 3 | 28 | Digital Input Line 4 ^a |
| 7 | Analog V_Output 3 | 27 | Digital Input Line 3 ^a |
| 6 | Analog I_Output 2 | 26 | Digital Input Line 2 ^a |
| 5 | Analog V_Output 2 | 25 | Digital Input Line 1 ^a |
| 4 | Analog I_Output 1 | 24 | Digital Input Line 0 ^a |
| 3 | Analog V_Output 1 | 23 | Digital Ground |
| 2 | Analog I_Output 0 | 22 | DAC_Sync |
| 1 | Analog V_Output 0 | 21 | Counter Input |

a. Supports interrupt-on-change.

DT9854 Screw Terminal Assignments

Table 32 lists the screw terminal assignments for the DT9854.

Table 34: DT9854 Screw Terminal Assignments

| Screw Terminal | Signal | Screw Terminal | Signal |
|----------------|--------------------------------|----------------|-----------------------------------|
| 20 | +5 V Out | 40 | Digital Output Line 7 |
| 19 | Digital I/O Termination Select | 39 | Digital Output Line 6 |
| 18 | Analog Ground | 38 | Digital Output Line 5 |
| 17 | Reserved | 37 | Digital Output Line 4 |
| 16 | Analog V_Output 7 | 36 | Digital Output Line 3 |
| 15 | Reserved | 35 | Digital Output Line 2 |
| 14 | Analog V_Output 6 | 34 | Digital Output Line 1 |
| 13 | Reserved | 33 | Digital Output Line 0 |
| 12 | Analog V_Output 5 | 32 | Digital Ground |
| 11 | Reserved | 31 | Digital Input Line 7 |
| 10 | Analog V_Output 4 | 30 | Digital Input Line 6 ^a |
| 9 | Analog Ground | 29 | Digital Input Line 5 ^a |
| 8 | Reserved | 28 | Digital Input Line 4 ^a |
| 7 | Analog V_Output 3 | 27 | Digital Input Line 3 ^a |
| 6 | Reserved | 26 | Digital Input Line 2 ^a |
| 5 | Analog V_Output 2 | 25 | Digital Input Line 1 ^a |
| 4 | Reserved | 24 | Digital Input Line 0 ^a |
| 3 | Analog V_Output 1 | 23 | Digital Ground |
| 2 | Reserved | 22 | DAC_Sync |
| 1 | Analog V_Output 0 | 21 | Counter Input |

a. Supports interrupt-on-change.

DT9854-M Screw Terminal Assignments

Table 35 lists the screw terminal assignments for the DT9854-M.

Table 35: DT9854-M Screw Terminal Assignments

| Screw Terminal | Signal | Screw Terminal | Signal |
|----------------|--------------------------------|----------------|-----------------------------------|
| 20 | +5 V Out | 40 | Digital Output Line 7 |
| 19 | Digital I/O Termination Select | 39 | Digital Output Line 6 |
| 18 | Analog Ground | 38 | Digital Output Line 5 |
| 17 | Analog I_Output 7 | 37 | Digital Output Line 4 |
| 16 | Analog V_Output 7 | 36 | Digital Output Line 3 |
| 15 | Analog I_Output 6 | 35 | Digital Output Line 2 |
| 14 | Analog V_Output 6 | 34 | Digital Output Line 1 |
| 13 | Analog I_Output 5 | 33 | Digital Output Line 0 |
| 12 | Analog V_Output 5 | 32 | Digital Ground |
| 11 | Analog I_Output 4 | 31 | Digital Input Line 7 |
| 10 | Analog V_Output 4 | 30 | Digital Input Line 6 ^a |
| 9 | Analog Ground | 29 | Digital Input Line 5 ^a |
| 8 | Analog I_Output 3 | 28 | Digital Input Line 4 ^a |
| 7 | Analog V_Output 3 | 27 | Digital Input Line 3 ^a |
| 6 | Analog I_Output 2 | 26 | Digital Input Line 2 ^a |
| 5 | Analog V_Output 2 | 25 | Digital Input Line 1 ^a |
| 4 | Analog I_Output 1 | 24 | Digital Input Line 0 ^a |
| 3 | Analog V_Output 1 | 23 | Digital Ground |
| 2 | Analog I_Output 0 | 22 | DAC_Sync |
| 1 | Analog V_Output 0 | 21 | Counter Input |

a. Supports interrupt-on-change.

LED Status Indicators

The DT9850 Series modules have a single bi-color LED that indicates the status of the module, as described in [Table 36](#).

Table 36: LED Status Indicators on the DT9850 Series Module

| Color of the LED | Status Description |
|------------------|--------------------------|
| Green | Module is powered |
| Blinking amber | Module is acquiring data |

A

- administrator privileges 27
- analog output
 - clock sources 54
 - continuous 57
 - data transfer 58
 - single value 55
 - single values 55
- analog output subsystem 53
 - calibrating 85
 - channels 53
 - data format 58
 - gain 53
 - operation modes 55
 - ranges 53
 - resolution 54
 - specifications 88
 - testing continuous operations 45
 - testing single-value operations 44
 - trigger sources 56
 - wiring 36
- applet, Open Layers Control Panel 61, 79
- application wiring
 - analog output 36
 - configuring digital input signals 38
 - connecting event counting signals 40
 - current output 36
 - digital inputs 39
 - digital outputs 39
 - voltage output 36
- applications
 - LV-Link 14
 - Quick DataAcq 14

B

- base clock frequency 73
- BaseClockFrequency 73
- binary data encoding 66
- buffers 58, 66

C

- C/C++ programs 14
- C/T subsystem
 - specifications 91, 92

- cables, USB 24, 25
- calibrating the module
 - analog output subsystem 85
 - running the calibration utility 84
- CGLDepth 67
- channel type
 - differential 67
 - single-ended 67
- channel-gain list depth 67
- channels
 - analog output 53
 - digital I/O 60
 - number of 67
- clock sources
 - analog output 54
- clocks
 - base frequency 73
 - external 73
 - internal 73
 - maximum external clock divider 73
 - maximum throughput 73
 - minimum external clock divider 73
 - minimum throughput 73
- connecting signals
 - analog output 36
 - configuring digital input signals 38
 - current output 36
 - digital inputs 39
 - digital outputs 39
 - event counting signals 40
 - voltage output 36
- connecting to the host computer 23
- continuous analog output 57
- continuous analog output operations 65
- continuous digital input 61
- Control Panel applet 61, 79
- counter input signal 62
- counter/timer 62
- counter/timer features
 - event counting 74
 - internal gate type 74
 - specifications 91, 92
- current output support 69
- customer service 81

D

- D/A subsystem 53
 - specifications 88
- DAC_Sync pin 55, 56
- DAQ Adaptor for MATLAB 14
- data encoding 66
- data flow modes
 - continuous 61
 - continuous analog output 65
 - single-value 61, 65
 - single-values 65
- data format 58
- data transfer
 - analog output 58
- DataAcq SDK 14
- device driver 14, 27
- differential channels 67
- digital I/O subsystems 60
 - configuring the state of digital input signals 38
 - interrupts 60
 - lines 60
 - operation modes 61
 - resolution 60
 - specifications 90
 - wiring inputs 39
 - wiring outputs 39
- DIN subsystem 60
 - specifications 90
- DOUT subsystem 60
 - specifications 90
- DT-Open Layers for .NET Class Library 14

E

- environmental specifications 93
- event counting 40, 74
- expansion hub 25
- external clock 73
- external clock divider
 - maximum 73
 - minimum 73
- external positive digital trigger for single value operations 72
- external trigger 56

F

- factory service 81
- features 12
- FIFOSize 65
- formatting data 58

- frequency 73
 - base clock 73
 - internal DAC clock 54
 - internal retrigger clock 66
- frequency measurement 40

G

- gain
 - analog output 53
 - number of 67
- gate type, software 74

H

- hardware features 12
- help, online 43
- hot-swapping 23

I

- IEPE support 71
- internal clock 73
- internal gate type 74
- interrupts 60, 65

L

- LabVIEW 14
- LED 24, 25
- LED status indicator 100
- legacy CPL elevated 27
- lines, digital I/O 60
- LV-Link 14

M

- MaxDifferentialChannels 67
- MaxExtClockDivider 73
- MaxFrequency 73
- MaxMultiScanCount 66
- MaxRetriggerFreq 66
- MaxSingleEndedChannels 67
- MinExtClockDivider 73
- MinFrequency 73
- MinRetriggerFreq 66

N

number of
 differential channels [67](#)
 gains [67](#)
 I/O channels [67](#)
 resolutions [68](#)
 scans per trigger [66](#)
 single-ended channels [67](#)
 voltage ranges [68](#)
 NumberOfChannels [67](#)
 NumberOfRanges [68](#)
 NumberOfResolutions [68](#)
 NumberOfSupportedGains [67](#)

O

online help [43](#)
 Open Layers Control Panel [27](#)
 Open Layers Control Panel applet [61](#), [79](#)
 operation modes [55](#)
 continuous analog output [57](#)
 continuous digital input [61](#)
 single-value analog output [55](#)
 single-value digital I/O [61](#)
 single-values analog output [55](#)
 output
 clock sources [54](#)
 output ranges [53](#)

P

physical specifications [93](#)
 ports [60](#)
 power [25](#), [26](#)
 specifications [93](#)
 preparing to wire signals [31](#)

Q

Quick DataAcq application [14](#)
 running [43](#)
 single-value digital input operations [46](#)
 single-value digital output operations [47](#)

R

ranges
 analog output [53](#)
 number of [68](#)
 recommendations for wiring [31](#)
 regulatory specifications [94](#)

resolution
 available [68](#)
 digital I/O [60](#)
 number of [68](#)
 programmable [68](#)
 resolution, analog output [54](#)
 retrigger clock frequency [66](#)
 returning boards to the factory [81](#)
 RMA [81](#)

S

SDK [14](#)
 simultaneous single-value operations [65](#)
 single buffer support [66](#)
 single-ended channels [67](#)
 single-value analog output [55](#)
 single-value operations [61](#), [65](#)
 single-values analog output [55](#)
 software trigger [56](#), [72](#)
 specifications [87](#)
 analog output [88](#)
 counter/timer [91](#), [92](#)
 digital I/O [90](#)
 environmental [93](#)
 physical [93](#)
 power [93](#)
 regulatory [94](#)
 stopping an operation [57](#)
 streaming [57](#)
 SupportedResolutions [68](#)
 SupportedVoltageRanges [68](#)
 SupportsBinaryEncoding [66](#)
 SupportsContinuous [65](#)
 SupportsCount [74](#)
 SupportsCurrentOutput [69](#)
 SupportsDifferential [67](#)
 SupportsExternalClock [73](#)
 SupportsGateNone [74](#)
 SupportsIEPE [71](#)
 SupportsInternalClock [73](#)
 SupportsInterruptOnChange [65](#)
 SupportsSetSingleValues [65](#)
 SupportsSingleEnded [67](#)
 SupportsSingleValue [65](#)
 SupportsSoftwareResolution [68](#)
 SupportsSoftwareTrigger [72](#)
 SupportsSvPosExternalTTLTrigger [72](#)
 SupportsWrapSingle [66](#)
 system requirements [22](#)

T

- technical support [80](#)
- throughput
 - maximum [73](#)
 - minimum [73](#)
- transferring data
 - analog output [58](#)
- trigger sources [56](#)
- triggered scan
 - number of scans per trigger [66](#)
 - retrigger frequency [66](#)
- triggers
 - external positive digital for single-value operations [72](#)
 - software [72](#)
- troubleshooting
 - procedure [78](#)
 - technical support [80](#)
 - troubleshooting table [78](#)

U

- unpacking [21](#)
- USB cable [24](#), [25](#)
- USB expansion hub [25](#)
- USB LED [24](#)

V

- Visual Basic for .NET programs [14](#)
- Visual C# programs [14](#)
- voltage ranges [68](#)
 - number of [68](#)

W

- wiring signals [31](#)
 - analog output [36](#)
 - configuring digital input signals [38](#)
 - current output [36](#)
 - digital inputs [39](#)
 - digital outputs [39](#)
 - event counting signals [40](#)
 - preparing [31](#)
 - recommendations [31](#)
 - voltage output [36](#)
- writing programs in
 - C/C++ [14](#)
 - Visual Basic .NET [14](#)
 - Visual C# [14](#)