

DT9824
User's Manual

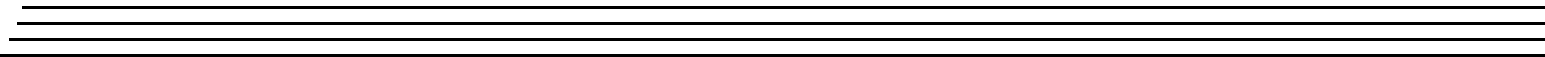
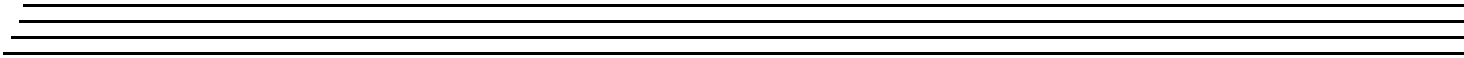
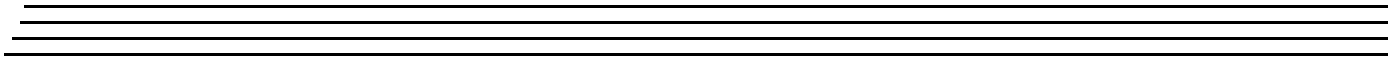

Trademark and Copyright Information

Measurement Computing Corporation, InstaCal, Universal Library, and the Measurement Computing logo are either trademarks or registered trademarks of Measurement Computing Corporation. Refer to the Copyrights & Trademarks section on mccdaq.com/legal for more information about Measurement Computing trademarks. Other product and company names mentioned herein are trademarks or trade names of their respective companies.

© 2015 Measurement Computing Corporation. All rights reserved. No part of this publication may be reproduced, stored in a retrieval system, or transmitted, in any form by any means, electronic, mechanical, by photocopying, recording, or otherwise without the prior written permission of Measurement Computing Corporation.

Notice

Measurement Computing Corporation does not authorize any Measurement Computing Corporation product for use in life support systems and/or devices without prior written consent from Measurement Computing Corporation. Life support devices/systems are devices or systems that, a) are intended for surgical implantation into the body, or b) support or sustain life and whose failure to perform can be reasonably expected to result in injury. Measurement Computing Corporation products are not designed with the components required, and are not subject to the testing required to ensure a level of reliability suitable for the treatment and diagnosis of people.

Radio and Television Interference

This equipment has been tested and found to comply with CISPR EN55022 Class A and EN61000-6-1 requirements and also with the limits for a Class A digital device, pursuant to Part 15 of the FCC Rules. These limits are designed to provide reasonable protection against harmful interference when the equipment is operated in a commercial environment. This equipment generates, uses, and can radiate radio frequency energy and, if not installed and used in accordance with the instruction manual, may cause harmful interference to radio communications. Operation of this equipment in a residential area is likely to cause harmful interference, in which case the user will be required to correct the interference at his own expense.

Changes or modifications to this equipment not expressly approved by Data Translation could void your authority to operate the equipment under Part 15 of the FCC Rules.

Note: This product was verified to meet FCC requirements under test conditions that included use of shielded cables and connectors between system components. It is important that you use shielded cables and connectors to reduce the possibility of causing interference to radio, television, and other electronic devices.

Canadian Department of Communications Statement

This digital apparatus does not exceed the Class A limits for radio noise emissions from digital apparatus set out in the Radio Interference Regulations of the Canadian Department of Communications.

Le présent appareil numérique n'émet pas de bruits radioélectriques dépassant les limites applicables aux appareils numériques de la class A prescrites dans le Règlement sur le brouillage radioélectrique édicté par le Ministère des Communications du Canada.

Table of Contents

About this Manual	9
Intended Audience	9
How this Manual is Organized	9
Conventions Used in this Manual	10
Related Information	10
Where To Get Help	10
Chapter 1: Overview	11
Features	12
Supported Software	14
Accessories	17
Getting Started Procedure	18
Part 1: Getting Started	19
Chapter 2: Installing the Module	21
Unpacking	23
System Requirements	24
Attaching Modules to the Computer	25
Connecting Directly to the Host Computer	25
Connecting to a Self-Powered USB Hub	26
Configuring the Driver	28
Chapter 3: Wiring Signals	29
Preparing to Wire Signals	31
Connecting Analog Input Signals	33
Connecting Digital I/O Signals	34
Connecting Digital Input Signals	35
Connecting Digital Output Signals	36
Chapter 4: Verifying the Operation of the Module	37
Running the Quick DataAcq Application	39
Testing Single-Value Analog Input	40
Testing Continuous Analog Input	41
Testing Single-Value Digital Input	42
Testing Single-Value Digital Output	43

Part 2: Using Your Module	45
Chapter 5: Principles of Operation	47
Analog Input Features	49
Analog Input Channels	49
Specifying a Single Analog Input Channel	49
Specifying One or More Analog Input Channels	49
Specifying the Digital Input Port in the Analog Input Channel List	50
Input Resolution	50
Input Ranges and Gains	50
A/D Sample Clock	50
Triggers	51
Analog Input Conversion Modes	51
Data Format	52
Data Transfer	53
Error Conditions	53
Digital I/O Features	54
Digital Input Lines	54
Digital Output Lines	54
Channel-to-Channel Isolation	55
Resolution	55
Operation Modes	55
Chapter 6: Supported Device Driver Capabilities	57
Data Flow and Operation Options	59
Buffering	60
Triggered Scan Mode	60
Data Encoding	60
Channels	61
Gain	61
Ranges	62
Resolution	62
Current and Resistance Support	62
Thermocouple, RTD, and Thermistor Support	63
IEPE Support	64
Bridge and Strain Gage Support	64
Start Triggers	65
Reference Triggers	65
Clocks	66
Counter/Timers	67
Tachometers	68

Chapter 7: Calibration	69
Overview	70
Using the Auto-Calibration Procedure	71
Using the Manual Calibration Procedure	72
Chapter 8: Troubleshooting	75
General Checklist	76
Technical Support	78
If Your Module Needs Factory Service	79
Appendix A: Specifications	81
Analog Input Specifications	82
Noise	84
Frequency Response and Input Bandwidth	85
Digital I/O Specifications	88
Power, Physical, and Environmental Specifications	89
Regulatory Specifications	90
Connector Specifications	91
Appendix B: Connector Pin Assignments and LED Status Indicators	93
Analog Input Screw Terminals	94
Digital I/O Connector	95
USB Connector	96
LED Status Indicators	97
Index	99

About this Manual

This manual describes how to install and set up your DT9824 module and device driver, and verify that your module is working properly.

This manual also describes the features of the DT9824 module, the capabilities of the device driver, and how to program the DT9824 module using the DT-Open Layers for .NET Class Library™ software. Troubleshooting and calibration information is also provided.

Note: For more information on the class library, refer to the *DT-Open Layers for .NET Class Library User's Manual*. If you are using the DataAcq SDK or a software application to program your device, refer to the documentation for that software for more information.

Intended Audience

This document is intended for engineers, scientists, technicians, or others responsible for using and/or programming the DT9824 module for data acquisition operations in the Microsoft® Windows XP, Windows Vista®, Windows 7, or Windows 8 operating systems. It is assumed that you have some familiarity with data acquisition principles and that you understand your application.

How this Manual is Organized

This manual is organized as follows:

- [Chapter 1, “Overview,”](#) describes the major features of the DT9824 module, as well as the supported software and accessories for the module, and provides an overview of the getting started procedure.
- [Chapter 2, “Installing the Module,”](#) describes how to install the DT9824 module and configure the device driver.
- [Chapter 3, “Wiring Signals,”](#) describes how to wire signals to a DT9824 module.
- [Chapter 4, “Verifying the Operation of the Module,”](#) describes how to verify the operation of a DT9824 module with the Quick DataAcq application.
- [Chapter 5, “Principles of Operation,”](#) describes all of the features of the module and how to use them in your application.
- [Chapter 6, “Supported Device Driver Capabilities,”](#) lists the data acquisition subsystems and the associated features accessible using the DT9824 Device Driver.
- [Chapter 7, “Calibration,”](#) describes how to calibrate the analog input circuitry of the DT9824 module.
- [Chapter 8, “Troubleshooting,”](#) provides information that you can use to resolve problems with the module and the device driver, should they occur.
- [Appendix A, “Specifications,”](#) lists the specifications of the DT9824 module.

- [Appendix B, “Connector Pin Assignments and LED Status Indicators,”](#) shows the pin assignments for the connectors and the screw terminal assignments for the DT9824 module.
- An index completes this manual.

Conventions Used in this Manual

The following conventions are used in this manual:

- Notes provide useful information or information that requires special emphasis, cautions provide information to help you avoid losing data or damaging your equipment, and warnings provide information to help you avoid catastrophic damage to yourself or your equipment.
- Items that you select or type are shown in **bold**.

Related Information

Refer to the following documents for more information on using the DT9824 module:

- *Benefits of the Universal Serial Bus for Data Acquisition*. This white paper describes why USB is an attractive alternative for data acquisition. It is available on the Data Translation web site (www.mccdaq.com).
- *QuickDAQ User's Manual* (UM-24774). This manual describes how to create a QuickDAQ application to acquire and analyze data from DT-Open Layers data acquisition devices.
- *DT-Open Layers for .NET User's Manual* (UM-22161). For programmers who are developing their own application programs using Visual C# or Visual Basic .NET, this manual describes how to use the DT-Open Layers for .NET Class Library to access the capabilities of Data Translation data acquisition devices.
- *DataAcq SDK User's Manual* (UM-18326). For programmers who are developing their own application programs using the Microsoft C compiler, this manual describes how to use the DT-Open Layers DataAcq SDK™ to access the capabilities of Data Translation data acquisition devices.
- *LV-Link Online Help*. This help file describes how to use LV-Link™ with the LabVIEW™ graphical programming language to access the capabilities of Data Translation data acquisition devices.

Where To Get Help

Should you run into problems installing or using a DT9824 module, the Data Translation Technical Support Department is available to provide technical assistance. Refer to [Chapter 8](#) starting on [page 75](#) for more information. If you are outside the United States or Canada, call your local distributor, whose number is listed on Data Translation's web site (www.mccdaq.com).



Overview

Features	12
Supported Software	14
Getting Started Procedure	18

Features

The DT9824, shown in [Figure 1](#), is a high-resolution (24-bit) data acquisition module for the Universal Serial Bus (USB).



Figure 1: DT9824 Module

Most computers have two or more USB ports that allow direct connection to USB devices. You can expand the number of USB devices attached to a single USB port by using expansion hubs. The DT9824 module is part of the high-power, bus-powered USB class; therefore, the module does not require external power, but the expansion hubs do require external power.

The DT9824 module resides outside of the PC and install with a single cable to ease installation. Modules can be “hot swapped,” or plugged and unplugged while the PC is on, making them useful for many data acquisition applications.

The DT9824 module provides the following major features:

- USB compatibility
- ISO-Channel™ protection eliminates noise and ground loops
 - ± 500 V galvanic isolation channel-to-channel for all analog input signals and to the host computer to protect signal integrity
- Four, simultaneous, 24-bit analog input channels
- Sampling frequency of up to 4800 Hz
- Input gains of 1, 8, 16, and 32 with an input range of ± 10 V to support the following effective ranges: ± 10 V, ± 1.25 V, ± 0.625 V, and ± 0.3125 V
- Continuously paced analog input operations
- Software-programmable trigger type (software or external digital trigger) to start analog input operations.

- 8 opto-isolated digital input lines
- 8 opto-isolated digital output lines; the outputs are solid-state relays that operate from ± 30 V at currents up to 400 mA (peak) AC or DC
- Digital I/O galvanically isolated to 250 V when using all digital input lines
- You can read the digital input port through the analog input data stream for correlating analog and digital measurements

Supported Software

The following software is available for use with the DT9824 module:

- **DT9824 Device Driver** – This software is provided on the Data Acquisition OMNI CD that is shipped with the module. The device driver allows you to use a DT9824 module with any of the supported software packages or utilities.
- **DT9824 Calibration Utility** – This software is provided on the Data Acquisition OMNI CD-ROM. The DT9824 Calibration Utility allows you to calibrate the analog input circuitry of the DT9824 module. Refer to [Chapter 7](#) starting on [page 69](#) for more information on this utility.
- **Quick DataAcq application** – This software is provided on the Data Acquisition OMNI CD that is shipped with the module. The Quick DataAcq application provides a quick way to get up and running using a DT9824 module. Using this application, you can verify key features of the module, display data on the screen, and save data to disk.
- **QuickDAQ Base Version** – The base version of QuickDAQ is free-of-charge and allows you to acquire and analyze data from all Data Translation USB and Ethernet devices, except the DT9841 Series, DT9817, DT9835, and DT9853/54. Using the base version of QuickDAQ, you can perform the following functions:
 - Discover and select your devices.
 - Configure all input channel settings for the attached sensors.
 - Load/save multiple hardware configurations.
 - Generate output stimuli (fixed waveforms, swept sine waves, or noise signals).
 - On each supported data acquisition device, acquire data from all channels supported in the input channel list.
 - Choose to acquire data continuously or for a specified duration.
 - Choose software or triggered acquisition.
 - Log acquired data to disk in an .hpf file.
 - Display acquired data during acquisition in either a digital display using the Channel Display window or as a waveform in the Channel Plot window.
 - Choose linear or logarithmic scaling for the horizontal and vertical axes.
 - View statistics about the acquired data, including the minimum, maximum, delta, and mean values and the standard deviation in the Statistics window.
 - Export time data to a .csv or .txt file; you can open the recorded data in Microsoft Excel® for further analysis.
 - Read a previously recorded .hpf data file.
 - Customize many aspects of the acquisition, display, and recording functions to suit your needs, including the acquisition duration, sampling frequency, trigger settings, filter type, and temperature units to use.

- **QuickDAQ FFT Analysis Option** – When enabled with a purchased license key, the QuickDAQ FFT Analysis option includes all the features of the QuickDAQ Base version plus basic FFT analysis features, including the following:
 - The ability to switch between the Data Logger time-based interface and the FFT Analyzer block/average-based interface.
 - Supports software, freerun, or triggered acquisition with accept and reject controls for impact testing applications.
 - Allows you to perform single-channel FFT (Fast Fourier Transform) operations, including AutoSpectrum, Spectrum, and Power Spectral Density, on the acquired analog input data. You can configure a number of parameters for the FFT, including the FFT size, windowing type, averaging type, integration type, and so on.
 - Allows you to display frequency-domain data as amplitude or phase.
 - Supports dB or linear scaling with RMS (root mean squared), peak, and peak-to-peak scaling options
 - Supports linear or exponential averaging with RMS, vector, and peak hold averaging options.
 - Supports windowed time channels.
 - Supports the following response window types: Hanning, Hamming, Bartlett, Blackman, Blackman Harris, and Flat top.
 - Supports the ability to lock the waveform output to the analysis frame time.
 - Allows you to configure and view dynamic performance statistics, including the input below full-scale (IBF), total harmonic distortion (THD), spurious free dynamic range (SFDR), signal-to-noise and distortion ratio (SINAD), signal-to-noise ratio (SNR), and the effective number of bits (ENOB), for selected time-domain channels in the Statistics window.
 - Supports digital IIR (infinite impulse response) filters
- **QuickDAQ Advanced FFT Analysis Option** – When enabled with a purchased software license, the QuickDAQ Advanced FFT Analysis option includes all the features of the QuickDAQ Base version with the FFT Analysis option plus advanced FFT analysis features, including the following:
 - Allows you to designate a channel as a Reference or Response channel.
 - Allows you to perform two-channel FFT analysis functions, including Frequency Response Functions (Inertance, Mobility, Compliance, Apparent Mass, Impedance, Dynamic Stiffness, or custom FRF) with H1, H2, or H3 estimator types, Cross-Spectrum, Cross Power Spectral Density, Coherence, and Coherent Output Power.
 - Supports the Exponential response window type.
 - Supports the following reference window types: Hanning, Hamming, Bartlett, Blackman, Blackman Harris, FlatTop, Exponential, Force, and Cosine Taper windows.
 - Supports real, imaginary, and Nyquist display functions.
 - Allows you to save data in the .uff file format.





- **DT-Open Layers for .NET Class Library** – Use this class library if you want to use Visual C# or Visual Basic for .NET to develop your own application software for a DT9824 module using Visual Studio 2003-2012; the class library complies with the DT-Open Layers standard.
- **DataAcq SDK** – Use the Data Acq SDK if you want to use Visual Studio 6.0 and Microsoft C or C++ to develop your own application software for a DT9824 module using Windows XP, Windows Vista, Windows 7, or Windows 8; the DataAcq SDK complies with the DT-Open Layers standard.
- **DAQ Adaptor for MATLAB** – Data Translation's DAQ Adaptor provides an interface between the MATLAB Data Acquisition (DAQ) subsystem from The MathWorks and Data Translation's DT-Open Layers architecture.
- **LV-Link** – LV-Link is included on the Data Acquisition OMNI CD. Use this optional software package if you want to use the LabVIEW graphical programming language to access the capabilities of the DT9824 module.

Refer to the Data Translation web site (www.mccdaq.com) for more information on the appropriate software package for your application.

Accessories

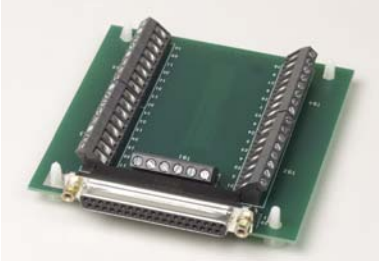
Table 1 lists the optional accessories are available for the DT9824.

Table 1: Optional Accessories Available for the DT9824

Accessory		Description
STP37		<p>The STP37 permits easy screw terminal connections for accessing the digital I/O signals on a DT9824 module.</p>
EP333		<p>The EP333 is a 2-meter shielded cable with two 37-pin connectors that connects the STP37 screw terminal panel to the digital I/O connector of the module.</p>
EP380		<p>Single rack-mount kit for mounting one DT8824 instrument module into a 1U rack.</p>
EP379		<p>Dual Rack-mount kit for mounting two DT8824 instrument modules side by side into a 1U rack.</p>

Getting Started Procedure

The flow diagram shown in [Figure 2](#) illustrates the steps needed to get started using the DT9824 module. This diagram is repeated in each getting started chapter; the shaded area in the diagram shows you where you are in the getting started procedure.

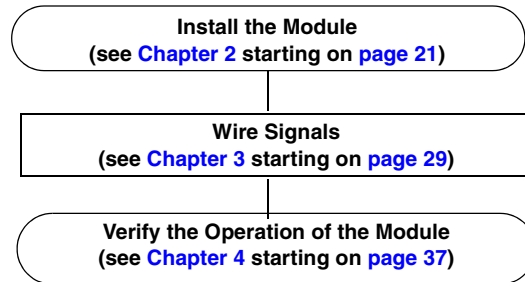

Figure 2: Getting Started Flow Diagram

Part 1: Getting Started



Installing the Module

Unpacking	23
System Requirements	24
Attaching Modules to the Computer	25
Configuring the Driver	28

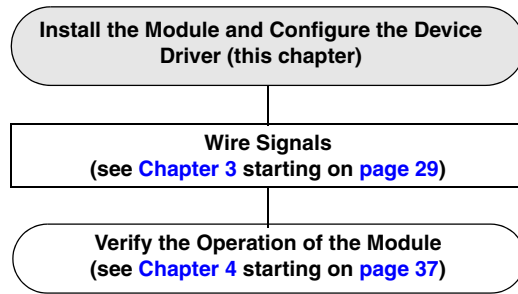

Unpacking

Open the shipping box and verify that the following items are present:

- DT9824 module
- EP365 USB cable
- Data Acquisition OMNI CD-ROM

If an item is missing or damaged, contact Data Translation. If you are in the United States, call the Customer Service Department at (508) 946-5100. An application engineer will guide you through the appropriate steps for replacing missing or damaged items. If you are located outside the United States, call your local distributor, listed on Data Translation's web site (www.mccdaq.com).

System Requirements

For reliable operation, ensure that your computer meets the following system requirements:

- Processor: Pentium 4/M or equivalent
- RAM: 1 GB
- Screen Resolution: 1024 x 768 pixels
- Operating System: Windows 8, Windows 7, Windows Vista (32- and 64-bit), or Windows XP SP3 (32-bit)
- Disk Space: 4 GB

Attaching Modules to the Computer

You can attach a DT9824 module to the host computer in one of two ways:

- Connect directly to a USB port of the host computer, described on [page 25](#). Use this method if one or two DT9824 modules are sufficient for your application.
- Connect to one or more self-powered USB hubs, described on [page 26](#). Use this method if your application requires more than two DT9824 modules connected to the host computer.

You **must** install the device driver before connecting your DT9824 module(s) to the host computer.

Note: The DT9824 module is a low-power device (using less than 500 mA); therefore, it does not require an external power supply.

Connecting Directly to the Host Computer

Generally, host computers have two or more USB ports. These ports are completely independent. To connect a DT9824 module directly to a USB port of the computer, do the following:

1. Attach one end of the EP365 cable, which is shipped with the DT9824 module, to the USB port on the module.
2. Attach the other end of the EP365 cable to one of the USB ports on the host computer, as shown in [Figure 3](#).

The operating system automatically detects the USB device and starts the Found New Hardware wizard.

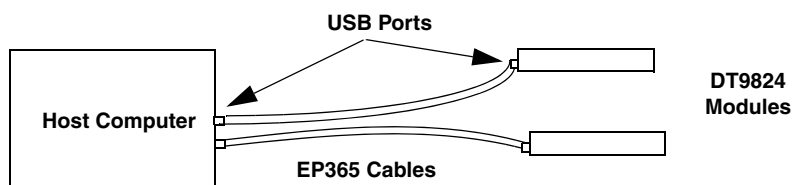

Figure 3: Attaching the DT9824 Module Directly to the Host Computer

3. *For Windows Vista:*
 - a. Click **Locate and install driver software (recommended)**.
The popup message "Windows needs your permission to continue" appears.
 - b. Click **Continue**.
The Windows Security dialog box appears.
 - c. Click **Install this driver software anyway**.

For Windows XP:

- a. Click **Next** and/or **Finish** as required in the wizard.
Once the firmware is loaded, the wizard restarts to initiate the firmware to accept commands.
- b. Click **Next** and/or **Finish** again.

Note: Windows 7 and Windows 8 find the device automatically.

4. Repeat these steps to attach another DT9824 module to the host computer, if desired.

Note: You can unplug a module, and then plug it in again, if you wish, without causing damage. This process is called hot-swapping.

Your application may take a few seconds to recognize a module once it is plugged back in.

Connecting to a Self-Powered USB Hub

Self-powered USB hubs are USB hubs that are powered by their own external power supply. The practical number of DT9824 modules that you can connect to a single USB port depends on the throughput you want to achieve.

Note: The bandwidth of the USB Ver. 1.1 bus is 12 Mbits/second. For each DT9824 module, the maximum sample rate is 4800 Samples/s x 4 bytes per samples x 5 channels (4 analog input channels and the digital input port). Therefore, if you want to achieve full throughput on each module, you should connect no more than four DT9824 modules to a single USB Ver. 1.1 port.

To connect a DT9824 module to a self-powered USB hub, do the following:

1. Attach one end of the EP365 cable to the DT9824 module and the other end of the EP365 cable to a self-powered USB hub.
2. Connect the power supply for the self-powered USB hub to an external power supply.
3. Connect the hub to the USB port on the host computer using another EP365 cable.
The operating system automatically detects the USB device and starts the Found New Hardware wizard.
4. *For Windows Vista:*
 - a. Click **Locate and install driver software (recommended)**.
The popup message "Windows needs your permission to continue" appears.
 - b. Click **Continue**.
The Windows Security dialog box appears.
 - c. Click **Install this driver software anyway**.

For Windows XP:

- a. Click **Next** and/or **Finish** as required in the wizard.
Once the firmware is loaded, the wizard restarts to initiate the firmware to accept commands.
- b. Click **Next** and/or **Finish** again.

Note: Windows 7 and Windows 8 find the device automatically.

5. Repeat these steps until you have attached the number of hubs and modules that you desire. Refer to [Figure 4](#).
The operating system automatically detects the USB devices as they are installed.

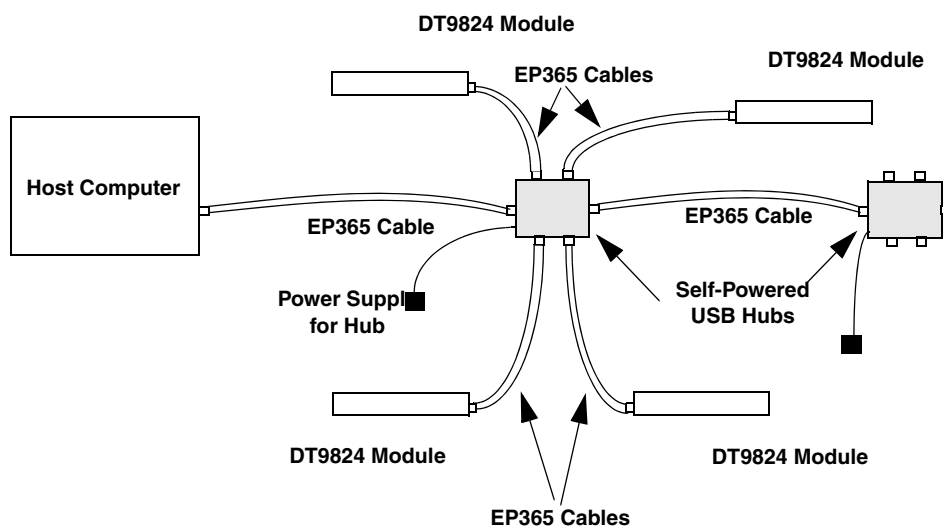

Figure 4: Attaching DT9824 Modules to the Host Computer Using Self-Powered USB Hubs

Note: You can unplug a module, and then plug it in again, if you wish, without causing damage. This process is called hot-swapping.

Your application may take a few seconds to recognize a module once it is plugged back in.

Configuring the Driver

Note: In Windows 7, Windows 8, and Vista, you must have administrator privileges to run the Open Layers Control Panel. When you double-click the Open Layers Control Panel icon, you may see the Program Compatibility Assistant. If you do, select **Open the control panel using recommended settings**. You may also see a Windows message asking you if you want to run the Open Layers Control Panel as a "legacy CPL elevated." If you get this message, click **Yes**.

If you do not get this message and have trouble making changes in the Open Layers Control Panel, right click the DTOLCPL.CPL file and select **Run as administrator**. By default, this file is installed in the following location:

Windows 7, Windows 8, and Vista (32-bit)

C:\Windows\System32\Dtolcpl.cpl

Windows 7, Windows 8, and Vista (64-bit)

C:\Windows\SysWOW64\Dtolcpl.cpl

To configure the DT9824 device driver, do the following:

1. If you have not already done so, power up the host computer and all peripherals.
2. From the Control Panel, double-click the **Open Layers Data Acquisition Control Panel** icon.
The Open Layers dialog box appears.
3. If you want to rename the module, click **Edit Name**; otherwise, go to step 5.
4. Enter a new name for the module, and then click **OK**.

Note: This name is used to identify the module in all subsequent applications.

5. When you are finished configuring the module, click **Close**.
6. Close the Control Panel.



Wiring Signals

Preparing to Wire Signals	31
Connecting Analog Input Signals	33
Connecting Digital I/O Signals	34

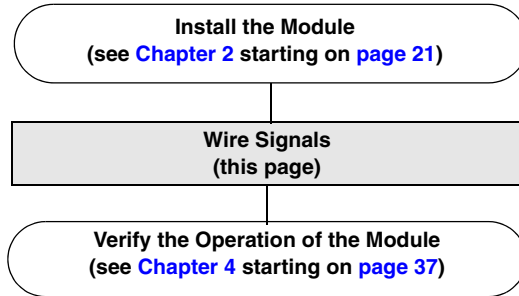

Preparing to Wire Signals

The front panel of the DT9824 module, shown in [Figure 5](#), contains four analog input channels with screw terminal connectors for connecting analog input signals. The rear panel of the DT9824 module, shown in [Figure 6](#), has a 37-pin digital I/O connector for attaching 8 opto-isolated digital input signals and 8 opto-isolated digital output signals.

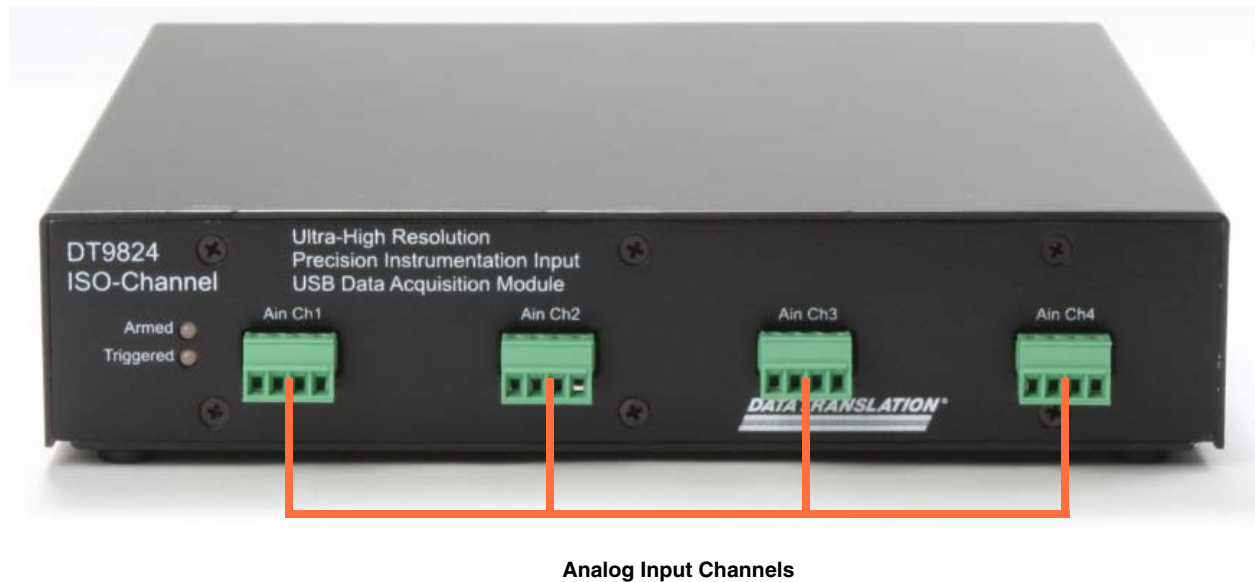

Figure 5: Analog Input Connectors of the DT9824 (Front Panel)



Figure 6: Digital I/O Connector of the DT9824 (Rear Panel)

Keep the following recommendations in mind when wiring signals to the DT9824 module:

- Follow standard ESD procedures when wiring signals to the module.
- Use individually shielded twisted-pair wire (size 14 to 26 AWG) when using the DT9824 module in highly noisy electrical environments.
- Separate power and signal lines by using physically different wiring paths or conduits.
- To avoid noise, do not locate the DT9824 module and cabling next to sources that produce high electromagnetic fields, such as large electric motors, power lines, solenoids, and electric arcs, unless the signals are enclosed in a mumetal shield.
- Prevent electrostatic discharge to the I/O while the DT9824 module is operational.
- Connect all unused analog input channels to analog ground.
- When first installing the module, try wiring the signals as follows:
 - Wire a function generator or a known voltage source to analog input channel 1 using the differential configuration.
 - Wire a digital input to digital input line 0.
 - Wire a digital output to digital output line 0.
 - Then, run the Quick DataAcq application (described in [Chapter 4](#) starting on [page 37](#)) to verify that the module is operating properly.

Once you have determined that the module is operating properly, wire the signals according to your application's requirements.

Connecting Analog Input Signals

You can connect analog input signals to the DT9824 module in the differential configuration only. [Figure 7](#) shows the numbering of the screw terminal blocks for analog input connections.

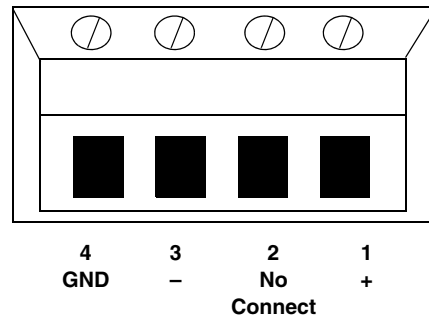

Figure 7: Screw Terminal Block Numbering for Analog Input Connections

[Figure 8](#) shows how to connect voltage inputs to the DT9824.

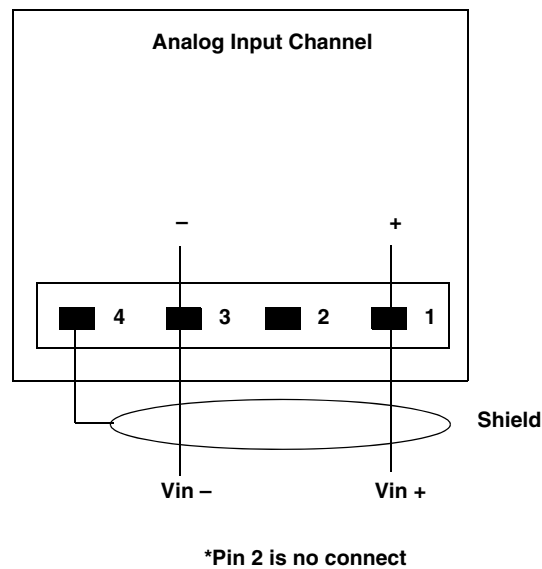

Figure 8: Connecting Voltage Inputs

Note: For best accuracy when connecting voltage inputs, use twisted-pair wires with a dead-ended shield connected to pin 4 of the screw terminal block.

Connecting Digital I/O Signals

To make digital I/O connections easier, you can use the optional STP37 screw terminal panel and EP333 cable with your DT9824 module. Connect the STP37 to the digital I/O connector of the module as shown in [Figure 9](#):



Connect the EP333 Cable to the Digital I/O Connector of DT9824 Module and to the STP37



Figure 9: Connecting the STP37 to the DT9824 Module

[Figure 10](#) shows the layout of the STP37 screw terminal panel and lists the assignments of each screw terminal.

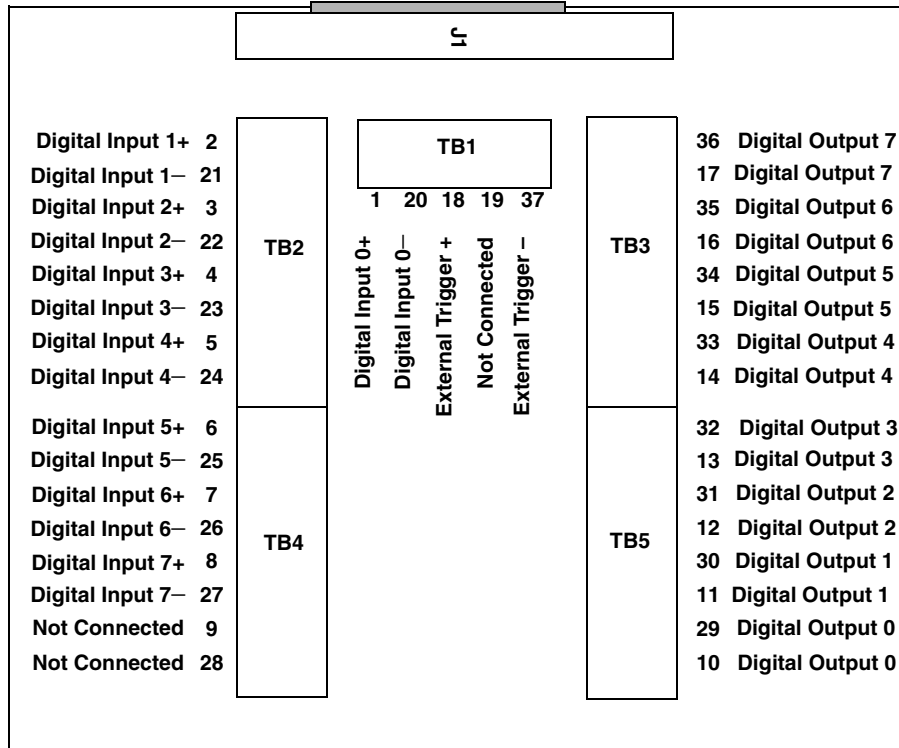
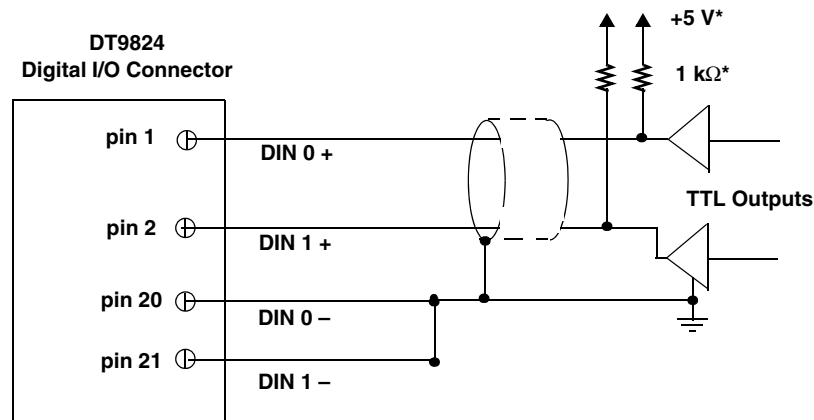

Figure 10: STP37 Screw Terminal Panel

Connecting Digital Input Signals

Figure 11 shows how to connect digital input signals (lines 0 and 1, in this case) to the digital I/O connector on the DT9824 module.



*1 kΩ pull-up to +5 V required for TTL outputs.

Figure 11: Connecting Digital Inputs

Connecting Digital Output Signals

The digital output lines on a DT9824 module act as solid-state relays. The customer-supplied signal can be ± 30 V at up to 400 mA (peak) AC or DC.

You can use the digital output lines of the module to control solid-state or mechanical relays or high-current electric motors. Figure 12 shows how to connect digital output signals to line 0 of the module to control a motor relay.

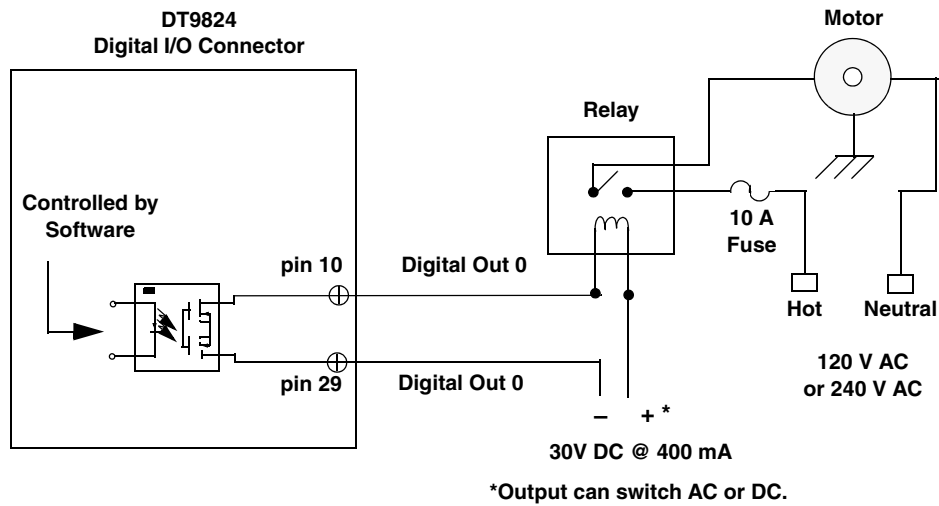
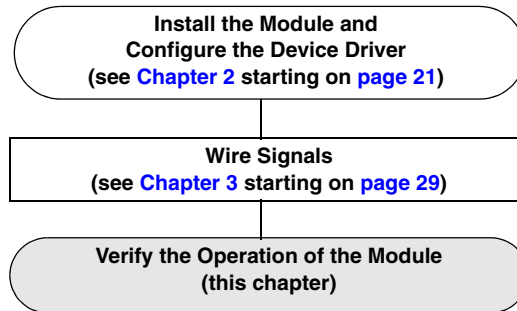

Figure 12: Switching up to 30 V at 400 mA



Verifying the Operation of the Module

Running the Quick DataAcq Application.....	39
Testing Single-Value Analog Input	40
Testing Continuous Analog Input	41
Testing Single-Value Digital Input.....	42
Testing Single-Value Digital Output	43



You can verify the operation of a DT9824 module using the Quick DataAcq application. The Quick DataAcq application allows you to do the following:

- Acquire data from a single analog input channel or digital input port
- Acquire data continuously from one or more analog input channels using an oscilloscope, strip chart, or Fast Fourier Transform (FFT) view
- Output data from a single digital output port
- Save the input data to disk

This chapter describes how to install and run the Quick DataAcq application.

Running the Quick DataAcq Application

The Quick DataAcq application is installed automatically when you install the driver software.

To run the Quick DataAcq application, do the following:

1. If you have not already done so, power up your computer and any attached peripherals.
2. Click **Start** from the Task Bar.
3. Browse to **Programs | Data Translation, Inc | DT-Open Layers for Win32 | QuickDataAcq**.
The main menu appears.

Note: The Quick DataAcq application allows you to verify basic operations on the board; however, it may not support all of the board's features.

For information on each of the features provided, use the online help for the Quick DataAcq application by pressing F1 from any view or selecting the **Help** menu. If the system has trouble finding the help file, navigate to C:\Program Files\Data Translation\Win32\dtdataacq.hlp, where C: is the letter of your hard disk drive.

Testing Single-Value Analog Input

To verify that the module can read a single analog input value, do the following:

1. Connect a voltage source, such as a function generator, to analog input channel 1 (differential mode) on the DT9824 module. Refer to [page 33](#) for information on connecting analog input signals.
2. In the Quick DataAcq application, choose **Single Analog Input** from the **Acquisition** menu.
3. Select the appropriate DT9824 module from the Board list box.

Note: Once you select the module, the LED on the module turns green.

4. In the Channel list box, select an index of 0 to select analog input channel 1.
5. In the Range list box, select the range for the channel.
The default is ± 10 V.
6. Select **Differential**.
7. Click **Get** to acquire a single value from analog input channel 1.
The application displays the value on the screen in both text and graphical form.

Testing Continuous Analog Input

To verify that the module can perform a continuous analog input operation, do the following:

1. Connect known voltage sources, such as the outputs of a function generator, to analog input channels 1 and 2 on the DT9824 module (using the differential configuration). Refer to [page 33](#) for more information on connecting analog input signals.
2. In the Quick DataAcq application, choose **Scope** from the **Acquisition** menu.
3. Select the appropriate DT9824 module from the Board list box.

Note: Once you select the module, the LED on the module turns green.

4. In the Sec/Div list box, select the number of seconds per division (.1 to .00001) for the display.
5. Click **Config** from the Toolbar.
6. From the Config menu, select **ChannelType**, and then select **Differential**.
7. From the Config menu, select **Range**, and then select **Bipolar**.
The default is Bipolar.
8. From the Scope view, double-click the input range of the channel to change the input range of the module: ± 10 V, ± 1.25 V, ± 0.625 V, or ± 0.3125 V.
The display changes to reflect the selected range for all the analog input channels on the module.
9. In the Trigger box, select **Auto** to acquire data continuously from the specified channels or **Manual** to acquire a burst of data from the specified channels.
10. Click **Start** from the Toolbar to start the continuous analog input operation.
The application displays the values acquired from each channel in a unique color on the oscilloscope view.

Note: When the module is performing a continuous Scope or FFT operation, the LED on the module turns green (the resulting color may appear yellow).

11. Click **Stop** from the Toolbar to stop the operation.

Testing Single-Value Digital Input

To verify that the module can read a single digital input value, do the following:

1. Connect a digital input to digital input line 0 of port A on the DT9824 module. Refer to [page 35](#) for more information on connecting digital inputs.
2. In the Quick DataAcq application, choose **Digital Input** from the **Acquisition** menu.
3. Select the appropriate DT9824 module from the Board list box.

Note: Once you select the module, the LED on the module turns green.

4. Select digital input port A by clicking **Port A**.
5. Click **Get**.
The application displays the value of each digital input line in port A on the screen in both text and graphical form.

Testing Single-Value Digital Output

To verify that the module can output a single digital output value, perform the following steps:

1. Connect a digital output to digital output line 0 of port B on the DT9824 module. Refer to [page 36](#) for more information on connecting digital outputs.
2. In the Quick DataAcq application, choose **Digital Output** from the **Control** menu.
3. Select the appropriate DT9824 module from the Board list box.

Note: Once you select the module, the LED on the module turns green.

4. Select digital output port B by clicking **Port B**.
5. Click the appropriate bits to select the type of signal to write from the digital output lines. If the bit is selected, a high-level signal is output from the digital output line; if the bit is not selected, a low-level signal is output from the digital output line. Optionally, you can enter an output value in the Hex text box.
6. Click **Send**.
The application outputs and displays the value of each digital output line of digital port B on the screen in both text and graphical form.

Part 2: Using Your Module



Principles of Operation

Analog Input Features	49
Digital I/O Features	54

Figure 13 shows a block diagram of the DT9824 module.

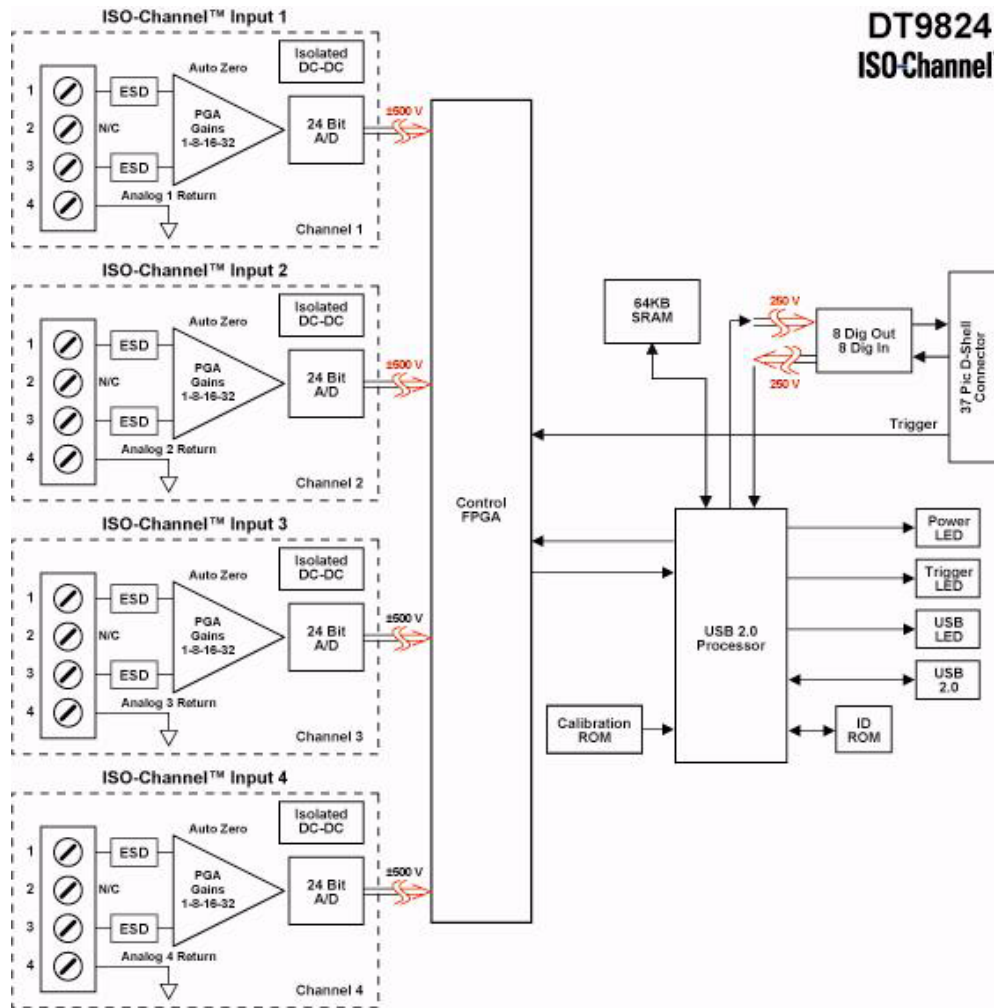

Figure 13: Block Diagram of the DT9824 Module

Analog Input Features

This section describes the following features of the analog input (A/D) subsystem on the DT9824 module:

- Analog input channels, described on [page 49](#)
- Input resolution, described on [page 50](#)
- Input ranges and gains, described on [page 50](#)
- A/D sample clock sources, described on [page 50](#)
- Analog input conversion modes, described on [page 51](#)
- Triggers, described on [page 51](#)
- Data formats, described on [page 52](#)
- Data transfer, described on [page 53](#)
- Error conditions, described on [page 53](#)

Analog Input Channels

The DT9824 module supports four, simultaneous, analog input channels, configured differentially. Refer to [Chapter 3](#) for more information on wiring to the analog input channels.

The DT9824 module can acquire data from a single analog input channel or from a group of analog input channels. In hardware analog input channels are numbered 1 to 4; in software, the index of a channel is zero-based. Therefore, to access channel 1, specify an index of 0 in software. Similarly, to access channel 4, specify an index of 3 in software.

Specifying a Single Analog Input Channel

The simplest way to acquire data from a single analog input channel is to use a single-value analog input operation using software; refer to [page 51](#) for more information about single-value operations.

You can also specify a single channel using the analog input channel list, described next.

Specifying One or More Analog Input Channels

You can read data from one or more analog input channels using an channel-gain list. Because the DT9824 module features simultaneous sampling, the order of the channels in the channel-gain list does not matter. You cannot specify the same channel more than once in the list.

Using software, specify the index (0 to 3) of the analog input channels that you want to sample. Refer to [page 51](#) for more information about the supported conversion modes.

Specifying the Digital Input Port in the Analog Input Channel List

Using the DT9824 module, you can also read the digital input port (all 8 digital input lines) in the analog input stream by specifying a channel index of 4 in the channel-gain list. This feature is particularly useful when you want to correlate the timing of analog and digital events. You can enter channel 4 anywhere in the channel-gain list.

The digital input port is treated like any other channel in the analog input channel list; therefore, all the clocking, triggering, and conversion modes supported for analog input channels are supported for the digital input port, if you specify them this way.

Input Resolution

The analog input resolution of the DT9824 module is fixed at 24 bits.

Input Ranges and Gains

The DT9824 module supports an input range of ± 10 V. In addition, you can choose from up to 4 gains (1, 8, 16, or 32). Table 2 lists the supported gains and effective input range of each input range on the DT9824 module.

Table 2: Effective Input Ranges

Gain	Input Range
1	± 10 V
8	± 1.25 V
16	± 0.625 V
32	± 0.3125 V

Choose the gain that has the smallest effective range that includes the signal you want to measure. For example, if the range of your analog input signal is ± 1.05 V, specify a range of ± 10 V for the A/D subsystem and use a gain of 8 for the channel; the effective input range for this channel is then ± 1.25 V, which provides the best sampling accuracy for that channel.

You can either specify the gain as part of the single-value operation. If you want to clock A/D conversions, specify the gain for the channel entry in the channel-gain list.

A/D Sample Clock

The DT9824 module provides an internal A/D sample clock with a minimum sampling frequency of 1.173 Hz and a maximum sampling frequency of 4800 Hz. All channels that are specified in the channel-gain list are sampled simultaneously at the specified sampling frequency.

As a guideline, the sampling frequency of the DT9824 should be at least 2.5 times the highest input signal frequency that you are trying to measure. For example, to accurately sample a 400 Hz signal, it is recommended that you specify a sampling frequency of at least 1000 Hz.

The actual frequency that the module can achieve may be slightly different than the frequency you specified due to the accuracy of the clock. You can determine the actual clock frequency using software.

Triggers

A trigger is an event that occurs based on a specified set of conditions. The DT9824 module supports the following trigger sources:

- **Software trigger** – A software trigger event occurs when you start the analog input operation (the computer issues a write to the module to begin conversions). Using software, specify the trigger source as a software trigger.
- **External trigger** – An external digital trigger occurs when the DT9824 module detects either a falling-edge or rising-edge on the External trigger line. The edge-type is software-programmable.

The external trigger connection is a differential input, allowing for TTL-level or switch connections. The positive side is pulled up to +5 V. If you are using the external trigger to detect a contact closure, ensure that you configure the polarity of the external trigger for a falling-edge (high-to-low) transition.

Analog Input Conversion Modes

The DT9824 module supports the following conversion modes:

- **Single-value operations** are the simplest to use but offer the least flexibility and efficiency. Using software, you can specify the range, gain, and index of the analog input channel, and acquire the data from that channel. The data is returned immediately. For a single-value operation, you cannot specify a clock source, trigger source, or buffer.

Single-value operations stop automatically when finished; you cannot stop a single-value operation.

- **Continuous mode** takes full advantage of the capabilities of the DT9824 module. You can specify a trigger source and buffer using software. (Refer to [page 53](#) for more information on buffers.)

You can stop a continuous operation by performing either an orderly stop or an abrupt stop using software. In an orderly stop, the module finishes acquiring the data, stops all subsequent acquisition, and transfers the acquired data to host memory; all subsequent triggers are ignored. In an abrupt stop, the module stops acquiring samples immediately; the acquired data is not transferred to host memory, and all subsequent triggers or retriggers are ignored.

The conversion rate is determined by the frequency of the A/D sample clock; refer to [page 50](#) for more information on the A/D sample clock.

DT9824 modules use an 8 kSample input FIFO for storing data from each of up to 5 enabled input channels (analog input indices 0 to 3, and the digital input port, index 4).

One sample from each of the enabled input channels is called a scan. In software, you specify the number of scans that you want to acquire in the input buffer.

You can specify one of the following wrap modes for the input buffer in software:

- Continuous wrap mode – Use this mode if you want the input operation to continue indefinitely. In this case, when the end of the input buffer is reached, the operation wraps to the beginning of the input buffer overwriting the oldest scan data with the latest scan data.
- No wrap mode – Use this mode if you want the input operation to stop automatically when the number of scans specified has been acquired.

Figure 14 illustrates continuous wrap mode using a channel list with five entries: analog input channel indices 0, 1, 2, 3, and the digital input data (index 4). In this example, data is acquired simultaneously on all channels on each clock pulse of the input sample clock. Data is acquired continuously until all the queued buffers have been filled or you stop the operation.

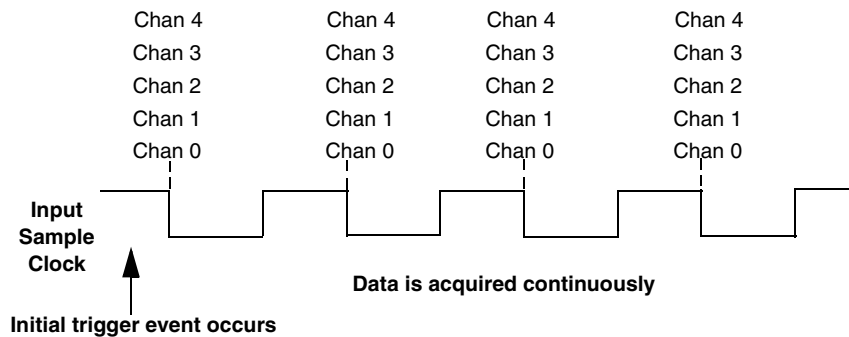

Figure 14: Continuous Wrap Mode

Data Format

The DT9824 module uses offset binary data encoding for the ± 10 V bipolar range.

Note: When the DT9824 is above range, the value FFFFFFFh (plus full-scale) is returned. When the DT9824 module is below range, the value 000000h (minus full-scale) is returned.

In software, the analog input value is returned as a code. To convert the code to voltage, use the following formulas:

$$\text{LSB} = \frac{\text{FSR}}{2^N}$$

$$V_{\text{in}} = \text{Code} * \text{LSB} + \text{Offset}$$

where,

- *LSB* is the least significant bit.
- *FSR* is the full-scale range. For the DT9824, the full-scale range is 20.
- *N* is the input resolution (24 bits).
- *V_{in}* is the analog voltage.
- *Code* is the raw count used by the software to represent the voltage.
- *Offset* is the actual minus full-scale value. The minus full-scale value is -10 V.

For example, if the software returns a code of 2010 for the analog input operation, determine the analog input voltage as follows:

$$\text{LSB} = \frac{20}{16777216} = 0.00000119 \text{ V}$$

$$V_{\text{in}} = 2010 * 0.00000119 + -10.0$$

$$V_{\text{in}} = -9.998 \text{ V}$$

Data Transfer

The DT9824 module transfers data to a user buffer that you allocate in the host computer. Keep the following recommendations in mind when allocating user buffers for continuous analog input operations on the DT9824 module:

- Allocate a minimum of two user buffers.
- Specify the width of the buffer as 4 bytes.

Data is written to the allocated buffers continuously until no more empty buffers are available or you stop the operation. The data is gap-free.

Error Conditions

The DT9824 module can report an A/D overrun error if the A/D sample clock rate is too fast. The error occurs if a new A/D sample clock pulse occurs while the ADC is busy performing a conversion from the previous A/D sample clock pulse. The host computer can clear this error. To avoid this error, use a slower sampling rate.

Digital I/O Features

The DT9824 module provides 8 digital input lines and 8 digital output lines that you can use to control external equipment, including solid-state or mechanical relays.

This section describes the following digital I/O features of the DT9824 modules:

- Digital input lines, described below
- Digital output lines, described on [page 54](#)
- Channel-to-channel isolation, described on [page 55](#)
- Resolution, described on [page 55](#)
- Operation modes, described on [page 55](#)

Digital Input Lines

The DT9824 module features eight, isolated, digital input lines.

Digital inputs operate from +3 to +28 V DC, with a switching time of 2 ms maximum. [Figure 15](#) shows the digital input circuitry; a 2.2 k Ω resistor is used in series with the LED in the opto-isolator input.

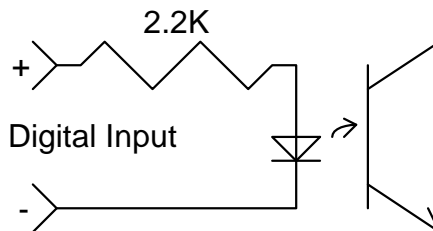

Figure 15: Digital Input Circuitry

A digital line is high (switch is closed) if its value is 1; a digital line is low (switch is open) if its value is 0.

Digital Output Lines

The DT9824 module features eight, latched and isolated digital output lines. The outputs are solid-state relays that operate at ± 30 V and 400 mA peak (AC or DC). Switching time is 2 ms maximum.

[Figure 16](#) shows the digital output circuitry.

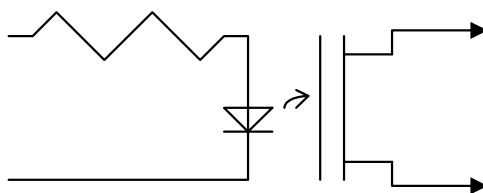

Figure 16: Digital Output Circuitry

Digital outputs resemble a switch; the switch is closed if the state of the digital output line is 1, and the switch is open if the state of the digital output line is 0. On power up or reset, the digital outputs are open.

Channel-to-Channel Isolation

The DT9824 module includes channel-to-channel isolation of up to 250 V between digital I/O lines. If you require greater channel-to-channel isolation, use every other digital line. This reduces the number of digital I/O lines, but provides channel-to-channel isolation of 500 V (one channel can be +250 V while the adjacent channel can be -250 V).

Resolution

The DT9824 module provides a resolution of eight bits for the digital input port to accommodate the eight isolated digital input lines and a resolution of eight bits for the digital output port to accommodate the eight isolated digital output lines. These lines are organized as isolated, dedicated ports. You cannot configure port resolution through software.

Operation Modes

The following digital I/O operation modes are supported for the DT9824 module:

- **Single-value operations** are the simplest to use but offer the least flexibility and efficiency. You use software to specify the digital input or output port (the gain is ignored). Data is then read from or written to the corresponding digital I/O lines.
- **Continuous digital input** takes full advantage of the capabilities of the DT9824 module using the analog input clock source, conversion mode, and buffer. The analog input sample clock then paces acquisition of the analog input channels as well as the digital input port; refer to [page 50](#) for more information about specifying the digital input port in the analog input channel-gain list.



Supported Device Driver Capabilities

Data Flow and Operation Options.....	59
Buffering	60
Triggered Scan Mode	60
Data Encoding.....	60
Channels	61
Gain	61
Ranges	62
Resolution	62
Current and Resistance Support	62
Thermocouple, RTD, and Thermistor Support	63
IEPE Support.....	64
Bridge and Strain Gage Support	64
Start Triggers.....	65
Reference Triggers	65
Clocks.....	66
Counter/Timers	67
Tachometers.....	68

The DT9824 Device Driver provides support for the analog input (A/D), digital input (DIN), and digital output (DOUT) subsystems. For information on how to configure the device driver, refer to [page 28](#).

Table 3: DT9824 Subsystems

DT9824	A/D	D/A	DIN	DOUT	C/T	TACH	QUAD
Total Subsystems on Module	1	0	1	1	0	0	0

The tables in this chapter summarize the features available for use with the DT-Open Layers for .NET Class Library and the DT9824 module. The DT-Open Layers for .NET Class Library provides properties that return support information for specified subsystem capabilities.

The first row in each table lists the subsystem types. The first column in each table lists all possible subsystem capabilities. A description of each capability is followed by the property used to describe that capability in the DT-Open Layers for .NET Class Library.

Note: The following tables include the capabilities that can be queried. However, some capabilities may not be supported by your device. Blank fields represent unsupported options.

For more information, refer to the description of these properties in the DT-Open Layers for .NET Class Library online help or *DT-Open Layers for .NET Class Library User's Manual*.

Data Flow and Operation Options

Table 4: Data Flow and Operation Options

DT9824	A/D	D/A	DIN	DOUT	C/T	TACH	QUAD
Single-Value Operation Support SupportsSingleValue	Yes		Yes	Yes			
Simultaneous Single-Value Output Operations SupportsSetSingleValues							
Continuous Operation Support SupportsContinuous	Yes		Yes				
Continuous Operation until Trigger SupportsContinuousPreTrigger							
Continuous Operation before & after Trigger SupportsContinuousPrePostTrigger							
Waveform Operations Using FIFO Only SupportsWaveformModeOnly							
Simultaneous Start List Support SupportsSimultaneousStart	Yes						
Supports Programmable Synchronization Modes SupportsSynchronization							
Synchronization Modes SynchronizationMode							
Interrupt Support SupportsInterruptOnChange							
FIFO Size FifoSize	8 kSamples						
Muting and Unmuting the Output Voltage SupportsMute							
Auto-Calibrate Support SupportsAutoCalibrate	Yes						

Buffering

Table 5: Buffering Options

DT9824	A/D	D/A	DIN	DOUT	C/T	TACH	QUAD
Buffer Support SupportsBuffering	Yes						
Single Buffer Wrap Mode Support SupportsWrapSingle							
Inprocess Buffer Flush Support SupportsInProcessFlush	Yes						

Triggered Scan Mode

Table 6: Triggered Scan Mode Options

DT9824	A/D	D/A	DIN	DOUT	C/T	TACH	QUAD
Triggered Scan Support SupportsTriggeredScan							
Maximum Number of CGL Scans per Trigger MaxMultiScanCount	1		0	0			
Maximum Retrigger Frequency MaxRetriggerFreq	0		0	0			
Minimum Retrigger Frequency MinRetriggerFreq	0		0	0			

Data Encoding

Table 7: Data Encoding Options

DT9824	A/D	D/A	DIN	DOUT	C/T	TACH	QUAD
Binary Encoding Support SupportsBinaryEncoding	Yes ^a		Yes	Yes			
Twos Complement Support SupportsTwosCompEncoding							
Returns Floating-Point Values ReturnsFloats							

a. The DT9824 uses offset binary encoding for the ± 10 V range.

Channels

Table 8: Channel Options

DT9824	A/D	D/A	DIN	DOUT	C/T	TACH	QUAD
Number of Channels NumberOfChannels	5 ^a	0	1	1	0		0
SE Support SupportsSingleEnded			Yes	Yes			
SE Channels MaxSingleEndedChannels	0		1	1			
DI Support SupportsDifferential	Yes						
DI Channels MaxDifferentialChannels	5		0	0			
Maximum Channel-Gain List Depth CGLDepth	5		0	0			
Simultaneous Sample-and-Hold Support SupportsSimultaneousSampleHold							
Channel-List Inhibit SupportsChannelListInhibit							
Support MultiSensor Inputs SupportsMultiSensor							
Bias Return Termination Resistor Support SupportsInputTermination							

a. You can acquire data from four analog input channels (indices 0 to 3) and the digital input port (index 4).

Gain

Table 9: Gain Options

DT9824	A/D	D/A	DIN	DOUT	C/T	TACH	QUAD
Programmable Gain Support SupportsProgrammableGain	Yes						
Number of Gains NumberOfSupportedGains	4		1	1			
Gains Available SupportedGains	1, 8, 16, 32		1	1			

Ranges

Table 10: Range Options

DT9824	A/D	D/A	DIN	DOUT	C/T	TACH	QUAD
Number of Voltage Ranges NumberOfRanges	1	0	0	0	0		0
Available Ranges SupportedVoltageRanges	±10 V						

Resolution

Table 11: Resolution Options

DT9824	A/D	D/A	DIN	DOUT	C/T	TACH	QUAD
Software Programmable Resolution SupportsSoftwareResolution							
Number of Resolutions NumberOfResolutions	1	0	1	1	0		0
Available Resolutions SupportedResolutions	24		8	8			

Current and Resistance Support

Table 12: Current and Resistance Support Options

DT9820 Series	A/D	D/A	DIN	DOUT	C/T	TACH	QUAD
Current Support SupportsCurrent							
Current Output Support SupportsCurrentOutput							
Resistance Support SupportsResistance							
Software Programmable External Excitation Current Source for Resistance SupportsExternalExcitationCurrentSrc							
Software Programmable Internal Excitation Current Source SupportsInternalExcitationCurrentSrc							
Available Excitation Current Source Values SupportedExcitationCurrentValues							

Thermocouple, RTD, and Thermistor Support

Table 13: Thermocouple, RTD, and Thermistor Support Options

DT9824	A/D	D/A	DIN	DOUT	C/T	TACH	QUAD
Thermocouple Support SupportsThermocouple							
RTD Support SupportsRTD							
Thermistor Support SupportsThermistor							
Voltage Converted to Temperature in Hardware SupportsTemperatureDataInStream							
Supported Thermocouple Types ThermocoupleType							
Supports CJC Source Internally in Hardware SupportsCjcSourceInternal							
Supports CJC Channel SupportsCjcSourceChannel							
Available CJC Channels CjcChannel							
Supports Interleaved CJC Values in Data Stream SupportsInterleavedCjcTemperaturesInStream							
Supported RTD Types RTDType							
RTD R0 Coefficient RtdR0							
Supports Temperature Filters SupportsTemperatureFilters							
Temperature Filter Types TemperatureFilterType							

IEPE Support

Table 14: IEPE Support Options

DT9824	A/D	D/A	DIN	DOUT	C/T	TACH	QUAD
IEPE Support SupportsIEPE							
Software Programmable AC Coupling SupportsACCoupling							
Software Programmable DC Coupling SupportsDCCoupling							
Software Programmable External Excitation Current Source SupportsExternalExcitationCurrentSrc							
Software Programmable Internal Excitation Current Source SupportsInternalExcitationCurrentSrc							
Available Excitation Current Source Values SupportedExcitationCurrentValues							

Bridge and Strain Gage Support

Table 15: Bridge and Strain Gage Support Options

DT9824	A/D	D/A	DIN	DOUT	C/T	TACH	QUAD
Bridge Support SupportsBridge							
Supported Bridge Configurations BridgeConfiguration							
Strain Gage Support SupportsStrainGage							
Supported Strain Gage Bridge Configurations StrainGageBridgeConfiguration							
External Excitation Voltage SupportsExternalExcitationVoltage							
Internal Excitation Voltage SupportsInternalExcitationVoltage							
Shunt Calibration SupportsShuntCalibration							
Voltage Excitation Per Channel SupportedPerChannelVoltageExcitation							
Minimum Excitation Voltage MinExcitationVoltage							
Maximum Excitation Voltage MaxExcitationVoltage							

Start Triggers

Table 16: Start Trigger Options

DT9824	A/D	D/A	DIN	DOUT	C/T	TACH	QUAD
Software Trigger Support SupportsSoftwareTrigger	Yes		Yes	Yes			
External Positive TTL Trigger Support SupportsPosExternalTTLTrigger	Yes						
External Negative TTL Trigger Support SupportsNegExternalTTLTrigger	Yes						
External Positive TTL Trigger Support for Single-Value Operations SupportsSvPosExternalTTLTrigger							
External Negative TTL Trigger Support for Single-Value Operations SupportsSvNegExternalTTLTrigger							
Positive Threshold Trigger Support SupportsPosThresholdTrigger							
Negative Threshold Trigger Support SupportsNegThresholdTrigger							
Digital Event Trigger Support SupportsDigitalEventTrigger							

Reference Triggers

Table 17: Reference Trigger Options

DT9824	A/D	D/A	DIN	DOUT	C/T	TACH	QUAD
External Positive TTL Trigger Support SupportsPosExternalTTLTrigger							
External Negative TTL Trigger Support SupportsNegExternalTTLTrigger							
Positive Threshold Trigger Support SupportsPosThresholdTrigger							
Negative Threshold Trigger Support SupportsNegThresholdTrigger							
Digital Event Trigger Support SupportsDigitalEventTrigger							
Sync Bus Support SupportsSyncBusTrigger							
Analog Input Channels Supported for the Threshold Trigger SupportedThresholdTriggerChannels							
Post-Trigger Scan Count Support SupportsPostTriggerScanCount							

Clocks

Table 18: Clock Options

DT9824	A/D	D/A	DIN	DOUT	C/T	TACH	QUAD
Internal Clock Support SupportsInternalClock	Yes						
External Clock Support SupportsExternalClock							
Simultaneous Input/Output on a Single Clock Signal SupportsSimultaneousClocking							
Base Clock Frequency BaseClockFrequency	4800 Hz		0	0			
Maximum Clock Divider MaxExtClockDivider	1.0		1.0	1.0			
Minimum Clock Divider MinExtClockDivider	1.0		1.0	1.0			
Maximum Frequency MaxFrequency	4800 Hz		0	0			
Minimum Frequency MinFrequency	1.173 Hz		0	0			

Counter/Timers

Table 19: Counter/Timer Options

DT9824	A/D	D/A	DIN	DOUT	C/T	TACH	QUAD
Cascading Support SupportsCascading							
Event Count Mode Support SupportsCount							
Generate Rate Mode Support SupportsRateGenerate							
One-Shot Mode Support SupportsOneShot							
Repetitive One-Shot Mode Support SupportsOneShotRepeat							
Up/Down Counting Mode Support SupportsUpDown							
Edge-to-Edge Measurement Mode Support SupportsMeasure							
Continuous Edge-to-Edge Measurement Mode Support SupportsContinuousMeasure							
High to Low Output Pulse Support SupportsHighToLowPulse							
Low to High Output Pulse Support SupportsLowToHighPulse							
Variable Pulse Width Support SupportsVariablePulseWidth							
None (internal) Gate Type Support SupportsGateNone							
High Level Gate Type Support SupportsGateHighLevel							
Low Level Gate Type Support SupportsGateLowLevel							
High Edge Gate Type Support SupportsGateHighEdge							
Low Edge Gate Type Support SupportsGateLowEdge							
Level Change Gate Type Support SupportsGateLevel							
Clock-Falling Edge Type SupportsClockFalling							
Clock-Rising Edge Type SupportsClockRising							
Gate-Falling Edge Type SupportsGateFalling							
Gate-Rising Edge Type SupportsGateRising							
Interrupt-Driven Operations SupportsInterrupt							

Tachometers

Table 20: Tachometer Options

DT9824	A/D	D/A	DIN	DOUT	C/T	TACH	QUAD
Tachometer Falling Edges SupportsFallingEdge							
Tachometer Rising Edges SupportsRisingEdge							
Tachometer Stale Data Flag SupportsStaleDataFlag							



Calibration

Overview	70
Using the Auto-Calibration Procedure	71
Using the Manual Calibration Procedure	72

Overview

DT9824 modules are calibrated at the factory and should not require calibration for initial use. We recommend that you check and, if necessary, readjust the calibration of the analog input circuitry on the DT9824 modules every six months using the DT9824 Calibration Utility, described in this chapter.

To calibrate the 24-bit A/D offset and A/D gain circuits on your module, you must use a precision voltage standard, such as the Krohn-Hite Model 523 or equivalent.

Using the Auto-Calibration Procedure

Note: Ensure that you let the DT9824 module warm-up for a minimum of 1 hour before calibrating it.

Auto-calibration is the easiest to use and is the recommended calibration method. To auto-calibrate the analog input subsystem, do the following:

1. From the Automatic Calibration area at the bottom of the window, select the channel to calibrate from the **Type of Calibration** drop-down list box.

2. Click the **Start** button.

The utility prompts you to connect 0 V to the channel to calibrate the offset at different gain settings and at different frequencies.

When calibrating 0 V, it is preferred that you connect a dead-short wire to the channel rather than supplying 0 V through the voltage source.

3. Ensure that you supply the correct voltage to the selected channel, and then click **OK**.

The utility prompts you to connect various voltages to the channel to calibrate the gain at different gain settings and at different frequencies.

4. Repeat steps 2 to 4 for the remaining A/D channels on the module, following the on-screen prompts.

Note: At any time, you can click **Restore Factory Settings** to reset the A/D calibration values to their original factory settings. This process will undo any auto or manual calibration settings.

Using the Manual Calibration Procedure

Note: Ensure that you let the DT9824 module warm-up for a minimum of 1 hour before calibrating it.

If you want to manually calibrate the analog input circuitry instead of auto-calibrating it, perform the following steps:

1. Select the A/D channel to calibrate (at the top of the window).
2. Select the frequency to use for the calibration (100 or 1200). If you select 100, the chopper is enabled for the A/D converter at frequencies equal to or lower than 960 Hz. If you select 1200, the chopper is disabled for the A/D converter at frequencies greater than 960 Hz.
3. Adjust the offset for the selected channel as follows:
 - a. Select the gain to apply to the channel (1, 8, 16, or 32).
 - b. To calibrate to 0 V, connect a dead-short wire to the selected channel.
The actual voltage is continuously returned in the AD Voltage text box. Since this number is constantly changing, a Running Average value is also displayed.
 - c. If desired, click the **Reset** button under the Running Average edit box to reset the running average.
 - d. Once the Running Average value has settled, adjust the offset by entering values in the Offset edit box, or by clicking the up/down buttons until the Running Average value matches 0 V.
 - e. Repeat steps 3a to 3d, selecting the next gain in the list, until the offset values are calibrated for each gain setting.
4. Adjust the gain for the selected channel as follows:
 - a. Select the gain to apply to the channel (1, 8, 16, or 32).
 - b. Apply the appropriate voltage, shown in [Table 21](#), for the selected gain.

Table 21: Voltages for Calibrating the Gain

Gain	Voltage to Apply
1	9.60000 V
8	1.20000 V
16	0.60000 V
32	0.30000V

- c. If desired, click the **Reset** button under the Running Average edit box to reset the Running Average value.

- d. Once the Running Average value has settled, adjust the gain by entering values in the Gain edit box, or by clicking the up/down buttons until the Running Average value matches the value you applied.
 - e. Repeat steps 4a to 4d, selecting the next gain in the list, until the gain values are calibrated for each gain setting.
5. Repeat steps 2 to 4 for the remaining frequency until the offset and gain values are calibrated for each frequency for the selected channel.
6. Repeat steps 1 to 5 for the remaining A/D channels that you want to calibrate.

Note: At any time, you can click **Restore Factory Settings** to reset the A/D calibration values to their original factory settings. This process will undo any auto or manual calibration settings.



Troubleshooting

General Checklist	76
Technical Support	78
If Your Module Needs Factory Service	79

General Checklist

Should you experience problems using the DT9824 module, follow these steps:

1. Read all the documentation provided for your product, including any “Read This First” information.
2. Check the OMNI CD for any README files and ensure that you have used the latest installation and configuration information available.
3. Check that your system meets the requirements stated on [page 24](#).
4. Check that you have installed your hardware properly using the instructions in [Chapter 2](#).
5. Check that you have installed and configured the device driver properly using the instructions in [Chapter 2](#).
6. Search the DT Knowledgebase in the Support section of the Data Translation web site (at www.mccdaq.com) for an answer to your problem.

If you still experience problems, try using the information in [Table 22](#) to isolate and solve the problem. If you cannot identify the problem, refer to [page 76](#).

Table 22: Troubleshooting Problems

Symptom	Possible Cause	Possible Solution
Module is not recognized	You plugged the module into your computer before installing the device driver.	From the Control Panel > System > Hardware > Device Manager, uninstall any unknown devices (showing a yellow question mark). Then, run the setup program on your OMNI CD to install the USB device drivers, and reconnect your USB module to the computer.
Module does not respond.	The module configuration is incorrect.	Check the configuration of your device driver.
	The module is damaged.	Contact Data Translation for technical support; refer to page 78 .
Intermittent operation.	Loose connections or vibrations exist.	Check your wiring and tighten any loose connections or cushion vibration sources.
	The module is overheating.	Check environmental and ambient temperature; consult the module’s specifications on page 89 of this manual and the documentation provided by your computer manufacturer for more information.
	Electrical noise exists.	Check your wiring and either provide better shielding or reroute unshielded wiring.

Table 22: Troubleshooting Problems (cont.)

Symptom	Possible Cause	Possible Solution
Device failure error reported.	The DT9824 module cannot communicate with the Microsoft bus driver or a problem with the bus driver exists.	Check your cabling and wiring and tighten any loose connections.
	The DT9824 module was removed while an operation was being performed.	Ensure that your DT9824 module is properly connected.
Data appears to be invalid.	An open connection exists.	Check your wiring and fix any open connections.
	A transducer is not connected to the channel being read.	Check the transducer connections.
	The module is set up for differential inputs while the transducers are wired as single-ended inputs or vice versa.	Check your wiring and ensure that what you specify in software matches your hardware configuration; the A/D configuration should be differential.
Computer does not boot.	The power supply of the computer is too small to handle all the system resources.	Check the power requirements of your system resources and, if needed, get a larger power supply; consult the module's specifications on page 89 of this manual.

Technical Support

If you have difficulty using the DT9824 module, Data Translation's Technical Support Department is available to provide technical assistance.

To request technical support, to go our web site at <http://www.mccdaq.com> and click on the Support link.

When requesting technical support, be prepared to provide the following information:

- Your product serial number
- The hardware/software product you need help on
- The version of the OMNI CD you are using
- Your contract number, if applicable

If you are located outside the USA, contact your local distributor; see our web site (www.mccdaq.com) for the name and telephone number of your nearest distributor.

If Your Module Needs Factory Service

Most hardware models can be functionally tested, evaluated for repairs (if needed), and calibrated to factory specifications. An RMA # must be obtained from Application Engineering in advance of sending any product back to Measurement Computing. Customers outside the USA must contact their local distributor for a return procedure. Calibration certificates for most analog models can be obtained for a fee (certificate must be requested at time of RMA # assignment).



Specifications

Analog Input Specifications	82
Digital I/O Specifications	88
Power, Physical, and Environmental Specifications	89
Regulatory Specifications	90
Connector Specifications	91

Analog Input Specifications

Table 23 lists the specifications for the A/D subsystem on the DT9824 module.

Table 23: A/D Subsystem Specifications

Feature	DT9824 Specifications
Number of analog inputs	4 Differential
Number of gains	4 (1, 8, 16, 32)
Resolution	24 bits
Data encoding	Offset binary
Coupling	DC
Sample frequency per channel	1.173 Hz to 4800 Hz
System accuracy @ 10 Hz (full-scale = 10 V) Gain = 1: Gain = 8: Gain = 16: Gain = 32:	0.001% 0.002% 0.003% 0.005%
System accuracy @ 100 Hz (full-scale = 10 V) Gain = 1: Gain = 8: Gain = 16: Gain = 32:	0.001% 0.002% 0.003% 0.006%
System accuracy @ 1200 Hz (full-scale = 10 V) Gain = 1: Gain = 8: Gain = 16: Gain = 32:	0.001% 0.002% 0.004% 0.007%
System accuracy @ 4800 Hz (full-scale = 10 V) Gain = 1: Gain = 8: Gain = 16: Gain = 32:	0.001% 0.003% 0.005% 0.010%
Nonlinearity (integral) Gain = 1: Gain > 1:	±5 ppm full-scale maximum ±15 ppm full-scale maximum
Differential linearity	±1.0 LSB (no missing codes)
Input range Gain = 1: Gain = 8: Gain = 16: Gain = 32:	±10 V ±1.25 V ±0.625 V ±0.3125 V

Table 23: A/D Subsystem Specifications (cont.)

Feature	DT9824 Specifications
Offset drift versus temperature ≤ 600Hz: > 600Hz:	50 nV/°C 150 nV/°C
Offset drift versus time	25 nV/1000 hours typical
Gain drift versus temperature	±10 ppm/°C
Gain drift versus time	10 ppm/1000 hours typical
Input impedance Power off: Power on:	3 kΩ 10 MΩ// 3 kΩ in series with 4700 pF
Input bias current	≤ ±1 nA
Input noise (@ 10 Hz sample rate; gain of 1)	3.6 μV rms = 23.6 μV pp or < 1.5 ppm (see Figure 17 on page 84)
System noise	See Table 24 and Figure 18 on page 85
Analog input filter	10 kHz
Common mode rejection @ 10 Hz	> -150 dB @ 50 Hz and 60 Hz
Common mode voltage	±500 V maximum (operational)
Maximum input voltage	±40 V maximum (protection)
Channel-to-channel offset	±10 μV
Effective number of bits (ENOB) @ 10 Hz with a 1 Hz, ±9.9 V sine wave input	21 bits typical
Channel crosstalk	-150 dB @ 1 kHz
Input coupling	DC
Isolation voltage	±500 V to computer ground
Channel-to-channel isolation	±500 V
ESD protection Arc: Contact:	8 kV 4 kV
Internal reference	1.25 V ±0.001 V
-3 dB point (low pass) ^a Sample rate less than or equal to 600 Samples/s Sample greater than 600 Samples/s	f -3 dB = 0.24 x fADC f -3 dB = 0.23 x fADC
Internal clock	±100 ppm maximum (typical initial ±25 ppm) ^b
Warm-up time	1 hour

a. Refer to [page 85](#) for more information about the frequency response, input bandwidth, and correction factors.

b. This clock is derived from the crystal oscillator. The specification includes initial tolerance, power supply variations, temperature drift, and 1 year stability.

Noise

Figure 17 shows the maximum noise measurement at 10 Hz with a gain of 1.

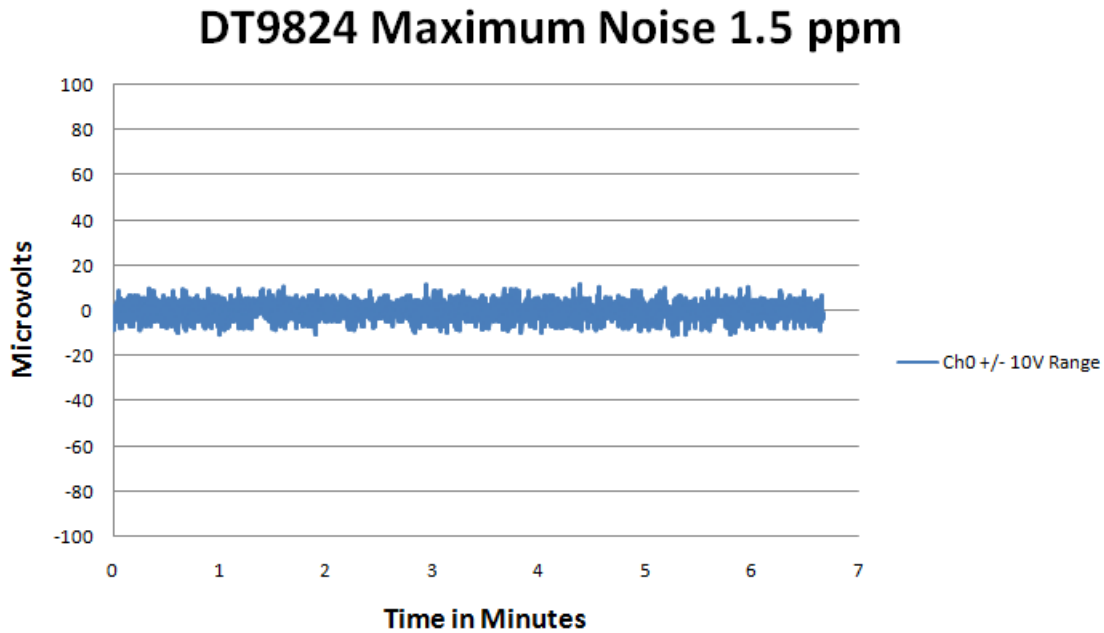

Figure 17: Maximum Noise Measurement During Typical Usage at 10 Hz with a Gain of 1

Figure 24 shows the typical RMS noise, in microvolts, of the DT9824 at sampling rates of 10 Samples/s, 100 Samples/s, 960 Samples/s, and 4800 Samples/s and gains of 1, 8, 16, and 32.

Table 24: DT9824 System Noise

Gain	10 Samples/s	100 Samples/s	960 Samples/s	4800 Samples/s
1	3.6 μ Vrms	12.0 μ Vrms	25.0 μ Vrms	63.0 μ Vrms
8	0.7 μ Vrms	2.0 μ Vrms	4.2 μ Vrms	11.0 μ Vrms
16	0.6 μ Vrms	1.8 μ Vrms	2.8 μ Vrms	7.5 μ Vrms
32	0.4 μ Vrms	1.3 μ Vrms	2.3 μ Vrms	6.5 μ Vrms

Figure 18 shows this data in graphical form.

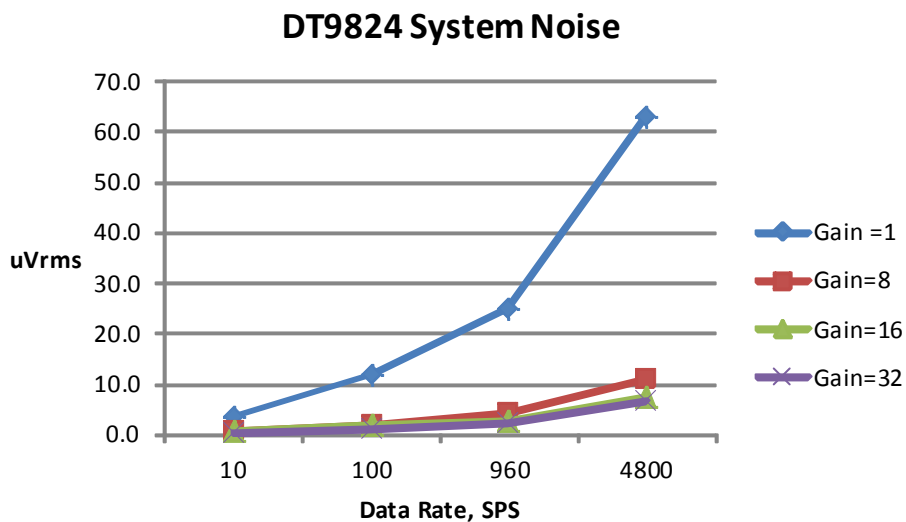

Figure 18: System Noise Specification

Frequency Response and Input Bandwidth

Each channel of the DT9824 includes a dedicated 24-bit Sigma-Delta A/D converter. The ultra-low noise and accuracy of these converters is achieved using an oversampling Sigma-Delta modulator followed by a multi-order Sinc filter and a digital low-pass filter/decimator.

The filter response has a gentle rolloff from DC with a 3 dB signal bandwidth that is determined by the user-selected sampling rate, shown in [Table 25](#).

Table 25: -3 dB Bandwidth

Sampling Frequency	-3 dB Bandwidth Point
Less than or equal to 600 Samples/s	0.24 x sample rate
Greater than 600 Samples/s	0.23 x sample rate

Figure 19 shows the frequency response using a sampling rate of 4800 Samples/s.

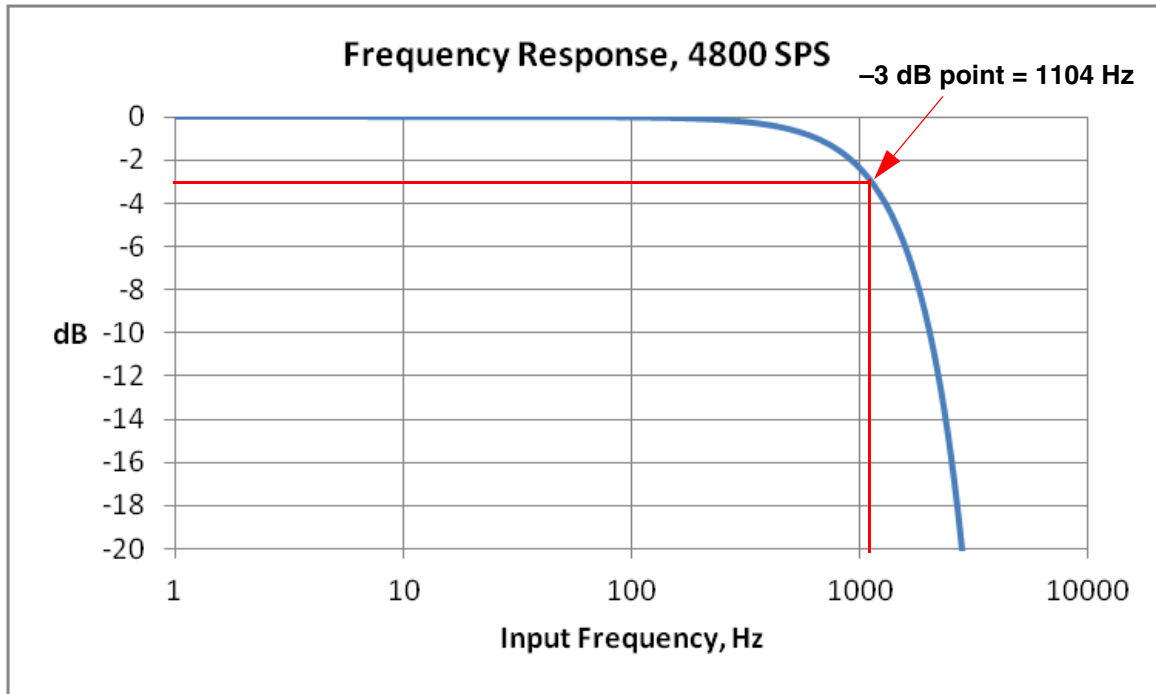

Figure 19: Frequency Response of the DT9824 When Using a Sampling Rate of 4800 Samples/s

As you can see, the frequency response of the DT9824 gently rolls off from DC due to the filtering of the Sigma-Delta A/D converter. You can use software to apply a correction factor to the acquired data to compensate for the filter response of the A/D converter. The correction factor depends on the input frequency of the signal you are trying to measure and the sampling rate of the DT9824. [Table 26](#) shows the gain correction factors for typical input frequencies and sampling rates.

Table 26: Gain Correction Factors

Frequency of the Input Signal (Hz)	Sampling Rate of the DT9824							
	10 Samples/s	25 Samples/s	60 Samples/s	100 Samples/s	600 Samples/s	960 Samples/s	1600 Samples/s	4800 Samples/s
DC	1.000	1.000	1.000	1.000	1.000	1.000	1.000	1.000
2	1.257	1.035	1.006	1.002	1.000	1.000	1.000	1.000
10	–	3.456	1.168	1.056	1.001	1.001	1.000	1.000
50	–	–	–	–	1.038	1.017	1.006	1.001
60	–	–	–	–	1.055	1.024	1.008	1.001
100	–	–	–	–	1.167	1.068	1.023	1.003
200	–	–	–	–	2.087	1.304	1.095	1.011
500	–	–	–	–	–	6.040	1.791	1.073
1000	–	–	–	–	–	–	–	1.325
2000	–	–	–	–	–	–	–	3.158

Digital I/O Specifications

Table 27 lists the specifications for the digital input (DIN) and digital output (DOU) subsystems on the DT9824 module.

Table 27: Digital I/O Specifications

Feature	DT9824 Specifications
Number of digital I/O lines	16 (8 Isolated Inputs, 8 Isolated Outputs)
Number of ports	2, 4-bit (1 In, 1 Out)
Inputs Input type: High input voltage: Low input voltage: High input current: Low input current: Termination:	DC +3 to +28 V < +1.5 V 2.2 k Ω resistor to 1.2 V 2.2 k Ω resistor to 1.2 V Series 2.2 k Ω
Outputs Output type: Output driver: High output: Low output: Breakdown voltage: Contact impedance:	Solid-state relay CMOS ± 30 V 0.4 V @ 400 mA ± 60 V 1 Ω
Isolation voltage To computer ground: Channel to channel	± 500 V ± 250 V ^a

- a. Determined by the pin spacing in the 37-pin digital connector. For greater channel-to-channel isolation, use every other digital I/O line; using every other digital I/O line allows ± 500 V isolation channel-to-channel.

Power, Physical, and Environmental Specifications

Table 28 lists the power, physical, and environmental specifications for the DT9824 module.

Table 28: Power, Physical, and Environmental Specifications

Feature	DT9824 Specifications
Power +5 V Standby: +5 V Enumeration: +5 V Power ON: Power Consumption:	500 μ A maximum 100 mA maximum (75 mA typical) 500 mA maximum (420 mA typical) 425 mA current draw
Physical Dimensions Width: Length: Height: Weight:	8.380 inches (212.85 mm) 9.319 inches (236.7 mm) 1.720 inches (43.69 mm) 31 ounces (880 g)
Environmental Operating temperature range: Storage temperature range: Relative humidity:	0° C to 55° C -25° C to 85° C To 95%, noncondensing

Regulatory Specifications

The DT9824 module is CE-compliant. [Table 29](#) lists the regulatory specifications for the DT9824 module.

Table 29: Regulatory Specifications

Feature	Specifications
Emissions (EMI)	FCC Part 15, Class A EN55011:2007 (Based on CISPR-11, 2003/A2, 2006)
Immunity	EN61326-1:2006 Electrical Equipment for Measurement, Control, and Laboratory Use <u>EMC Requirements</u> EN61000-4-2:2009 Electrostatic Discharge (ESD) 4 kV contact discharge, 8 kV air discharge, 4 kV horizontal and vertical coupling planes EN61000-4-3:2006 Radiated electromagnetic fields, 3 V/m, 80 to 1000 MHz; 3 V/m, 1.4 GHz to 2 GHz; 1 V/m, 2 GHz to 2.7 GHz EN61000-4-4:2004 Electrical Fast Transient/Burst (EFT) 1 kV on data cables EN61000-4-6:2009 Conducted immunity requirements, 3 Vrms on data cables 150 kHz to 80 MHz
RoHS (EU Directive 2002/95/EG)	Compliant (as of July 1st, 2006)

Connector Specifications

Table 30 lists the cable and connector specifications for the DT9824 module.

Table 30: DT9824 Cable and Connector Specifications

Feature	DT9824 Specifications
USB cable	2-meter, Type A-B, USB cable Data Translation part#17394 or AMP part# 974327-1
4-position Screw terminal block	Header: Phoenix Contact 1803293 Plug: Phoenix Contact 1803594
37-pin Digital I/O connector Connector on module: Mating connector:	37-pin D, AMP part# 5747847-4 AMP/Tyco part# 5-747916-2



Connector Pin Assignments and LED Status Indicators

Analog Input Screw Terminals	94
Digital I/O Connector	95
USB Connector	96
LED Status Indicators	97

Analog Input Screw Terminals

Figure 20 shows the terminal blocks for each analog input channel on the DT9824 module.

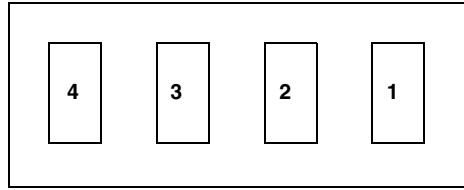

Figure 20: Screw Terminals of the Analog Input Channels

Table 31 summarizes the screw terminal assignments.

Table 31: Screw Terminal Assignments for the Analog Input Channels

Screw Terminals	Signal Description
1	Analog Input +
2	Not Connected
3	Analog Input –
4	Analog Ground

Digital I/O Connector

Figure 21 shows the pin locations of the digital I/O connector on the DT9824 module.

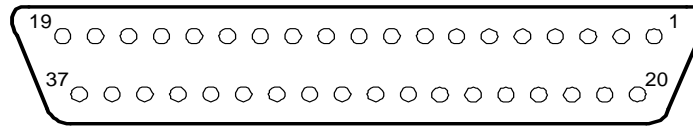

Figure 21: Digital I/O Connector

Table 32 lists the pin assignments of the digital I/O connector.

Table 32: Digital I/O Connector Pin Assignments

Pin	Signal Description	Pin	Signal Description
1	Digital Input 0 +	20	Digital Input 0 –
2	Digital Input 1 +	21	Digital Input 1 –
3	Digital Input 2 +	22	Digital Input 2 –
4	Digital Input 3 +	23	Digital Input 3 –
5	Digital Input 4 +	24	Digital Input 4 –
6	Digital Input 5 +	25	Digital Input 5 –
7	Digital Input 6 +	26	Digital Input 6 –
8	Digital Input 7 +	27	Digital Input 7 –
9	Not Connected	28	Not Connected
10	Digital Output 0	29	Digital Output 0
11	Digital Output 1	30	Digital Output 1
12	Digital Output 2	31	Digital Output 2
13	Digital Output 3	32	Digital Output 3
14	Digital Output 4	33	Digital Output 4
15	Digital Output 5	34	Digital Output 5
16	Digital Output 6	35	Digital Output 6
17	Digital Output 7	36	Digital Output 7
18	External Trigger +	37	External Trigger –
19	Not Connected		

Note: The outer shell of the connector provides the cable shield to chassis ground.

USB Connector

Figure 22 shows the pin locations of the USB connector on the DT9824 module.

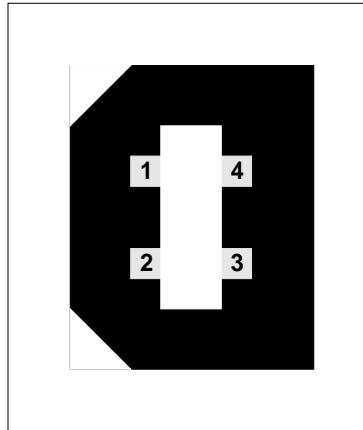

Figure 22: USB Connector

Table 33 lists the pin assignments of the digital I/O connector.

Table 33: USB Connector Pin Assignments

Pin	Signal Description	Pin	Signal Description
1	USB +5 V	3	USB Data +
2	USB Data –	4	USB Ground

LED Status Indicators

Each DT9824 module has a single bi-color LED that indicates the status of the module, as described in [Table 34](#).

Table 34: LED Status Indicators on the DT9824 Module

Color of the LED	Status Description
Green	Module is powered
Blinking amber	Module is acquiring data

A

- A/D sample clock 50
- A/D subsystem, specifications 82
- A/D trigger 51
- accessories 17
- administrator privileges 28
- analog input features
 - A/D sample clock 50
 - adding a digital input port to the channel list 50
 - channel list 49
 - channels 49
 - conversion modes 51
 - data format 52
 - data transfer 53
 - differential channels 33
 - error conditions 53
 - gain 50
 - input ranges 50
 - resolution 50
 - specifications 82
 - testing continuous operations 41
 - testing single-value operations 40
 - triggers 51
 - wiring voltage inputs 33
- application wiring
 - digital inputs 35
 - digital outputs 36
 - voltage inputs 33
- applications
 - Quick DataAcq 14
 - QuickDAQ 14

B

- base clock frequency 66
- BaseClockFrequency 66
- binary encoding 52, 60
- buffers 60
 - inprocess flush 60

C

- C/C++ programs 16
- cables
 - EP333 34
 - EP365 25, 26

- calibration 70
- CGLDepth 61
- channel list
 - for analog input channels 49
 - for digital input port 50
- channel type
 - differential 61
 - single-ended 61
- channel-gain list depth 61
- channels
 - analog input 49
 - digital I/O 54
 - number of 61
- clocks
 - base frequency 66
 - internal 66
 - maximum external clock divider 66
 - maximum throughput 66
 - minimum external clock divider 66
 - minimum throughput 66
- connecting signals
 - digital inputs 35
 - digital outputs 36
 - voltage inputs 33
- connecting to the host computer
 - directly 25
 - using a self-powered USB hub 26
- connector J1 pin assignments 97
- continuous analog input 59
- continuous digital input 55
- continuous wrap mode 52
- conversion modes 51
 - digital I/O 55
 - single-value analog input 51
- conversion rate 51
- counter/timer
 - channels 61
 - clock sources 66
- customer service 79

D

- DAQ Adaptor for MATLAB 16
- data encoding 60
- data flow modes
 - continuous analog input 59
 - single-value 59

- data transfer 53
- DataAcq SDK 16
- description of the functional subsystems
 - A/D 49
 - digital I/O 54
- device driver 14
- differential channels 61
- digital I/O features
 - adding a digital input port to the analog input channel list 50
 - channel-to-channel isolation 55
 - connecting input signals 35
 - connecting output signals 36
 - lines 54
 - operation modes 55
 - resolution 55
 - specifications 88
 - testing input operations 42
 - testing output operations 43
- digital trigger 51
- DT9824 Calibration Utility 14
- DT9824 Device Driver 14
- DT-Open Layers for .NET Class Library 16

E

- encoding 52
- environmental specifications 89, 91
- EP333 cable 17, 34
- EP365 cable 25, 26
- EP379 dual rack-mount kit 17
- EP380 single rack-mount kit 17
- errors, analog input 53
- external clock divider
 - maximum 66
 - minimum 66
- external digital trigger 51
 - negative 65
 - positive 65

F

- factory service 79
- features 12
- FIFO, input 51
- formatting data 52
- frequency
 - base clock 66
 - internal A/D clock 66
 - internal A/D sample clock 66
 - internal C/T clock 66

- internal retrigger clock 60

G

- gain
 - actual available 61
 - analog input 50
 - number of 61
 - programmable 61

H

- help 75
- help, online 39
- high drive digital outputs 36
- hot-swapping 26, 27

I

- inprocess buffers 60
- input configuration 33
- input FIFO 51
- input ranges 50
- internal clock 66

J

- J1 connector pin assignments 97

L

- LabVIEW 16
- LED status indicator 97
- legacy CPL elevated 28
- LV-Link 16

M

- MATLAB 16
- MaxDifferentialChannels 61
- MaxExtClockDivider 66
- MaxFrequency 66
- MaxMultiScanCount 60
- MaxRetriggerFreq 60
- MaxSingleEndedChannels 61
- mechanical relays, controlling 36
- MinExtClockDivider 66
- MinFrequency 66
- MinRetriggerFreq 60
- module specifications 89, 91
- multiple channels, analog input 49

N

no wrap mode [52](#)
 number of
 differential channels [61](#)
 gains [61](#)
 I/O channels [61](#)
 resolutions [62](#)
 scans per trigger [60](#)
 single-ended channels [61](#)
 voltage ranges [62](#)
 NumberOfChannels [61](#)
 NumberOfRanges [62](#)
 NumberOfResolutions [62](#)
 NumberOfSupportedGains [61](#)

O

offset binary encoding [52, 60](#)
 online help [39](#)
 Open Layers Control panel [28](#)
 operation modes
 continuous digital input [55](#)
 single-value analog input [51](#)
 single-value digital I/O [55](#)
 orderly stop [51](#)

P

physical specifications [89, 91](#)
 pin assignments [97](#)
 power specifications [89, 91](#)

Q

Quick DataAcq [14](#)
 running [39](#)
 QuickDAQ
 Advanced FFT Analysis option [15](#)
 Base version [14](#)
 FFT Analysis option [15](#)

R

rack-mount kits
 EP379 [17](#)
 EP380 [17](#)
 ranges
 analog input [50](#)
 number of [62](#)
 resolution [55](#)
 analog input [50](#)

 available [62](#)
 number of [62](#)
 retrigger clock frequency [60](#)
 returning modules to the factory [79](#)
 RMA [79](#)
 running the Quick DataAcq application [39](#)

S

scan [52](#)
 screw terminal assignments [33](#)
 screw terminal panel [17, 34](#)
 SDK [16](#)
 service and support procedure [78](#)
 simultaneous start list [59](#)
 single channel analog input [49](#)
 single-ended channels [61](#)
 single-value operations [59](#)
 analog input [51](#)
 digital I/O [55](#)
 size, module [89](#)
 software supported [14](#)
 software trigger [51, 65](#)
 solid-state relays, controlling [36](#)
 sourcing [36](#)
 specifications [81](#)
 analog input [82](#)
 digital I/O [88](#)
 environmental [89, 91](#)
 physical [89, 91](#)
 power [89, 91](#)
 regulatory [90](#)
 stopping an operation [51](#)
 STP37 screw terminal panel [17, 34](#)
 subsystem descriptions
 A/D [49](#)
 digital I/O [54](#)
 SupportedGains [61](#)
 SupportedResolutions [62](#)
 SupportedVoltageRanges [62](#)
 SupportsBinaryEncoding [60](#)
 SupportsBuffering [60](#)
 SupportsContinuous [59](#)
 SupportsDifferential [61](#)
 SupportsInProgressFlush [60](#)
 SupportsInternalClock [66](#)
 SupportsNegExternalTTLTrigger [65](#)
 SupportsPosExternalTTLTrigger [65](#)
 SupportsProgrammableGain [61](#)
 SupportsSimultaneousStart [59](#)
 SupportsSingleEnded [61](#)

SupportsSingleValue [59](#)
SupportsSoftwareTrigger [65](#)
system requirements [24](#)

T

technical support [78](#)
throughput
 maximum [66](#)
 minimum [66](#)
transferring data [53](#)
triggered scan
 number of scans per trigger [60](#)
 retrigger frequency [60](#)
triggers [51](#)
 external [51](#)
 external negative digital [65](#)
 external positive digital [65](#)
 software [51](#), [65](#)
troubleshooting
 procedure [76](#)
 service and support procedure [78](#)
 troubleshooting table [76](#)
TTL trigger [51](#)

U

unpacking [23](#)
USB cable [25](#), [26](#)

V

Visual Basic for .NET programs [16](#)
Visual C# programs [16](#)
voltage ranges [50](#), [62](#)
 number of [62](#)

W

wiring signals
 digital inputs [35](#)
 digital outputs [36](#)
 voltage inputs [33](#)
writing programs in
 C/C++ [16](#)
 Visual Basic .NET [16](#)
 Visual C# [16](#)