

**INDEX**

- 1. Power Map, JTAG Map**
- 2. PMODs**
- 3. CK Headers**
- 4. Buttons, Switches, UART**
- 5. VGA, LEDs**
- 6. 7 Segment Displays**
- 7. HDMI**
- 8. Audio**
- 9. USB Host**
- 10. Ethernet**
- 11. SFPs**
- 12. USB HID, SD Card**
- 13. USB Programming/UART**
- 14. FPGA Programming, JTAG Header, Serial Flash**
- 15. FPGA Banks 12, 13, 14**
- 16. FPGA Banks 15, 16, 17**
- 17. FPGA Banks 18, 32, 33**
- 18. FPGA Banks, 34, 115-118**
- 19. FPGA Power**
- 20. DDR3 Memory**
- 21. DDR3 Memory**
- 22. Static RAM**
- 23. Page Flash Memory**
- 24. Power Regulation, Power Switch**
- 25. Power Regulation**
- 26. Power Regulation**
- 27. Power Control**

**POWER MAP**

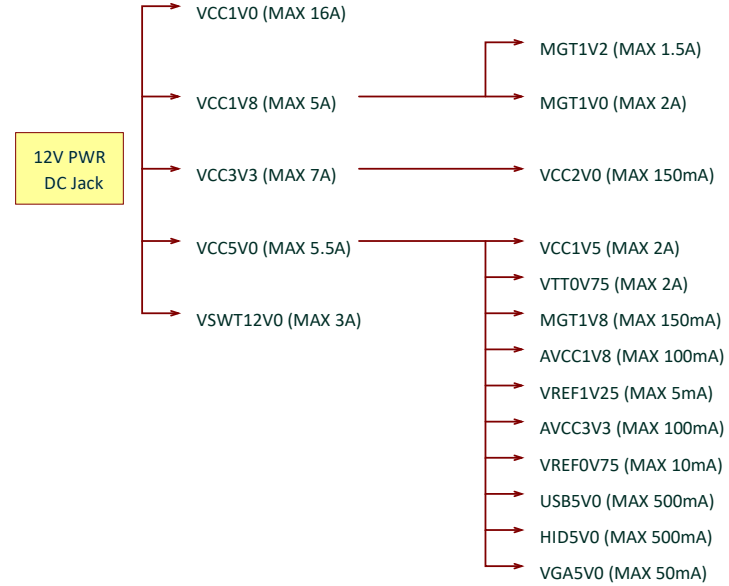

**JTAG SCAN CHAIN**

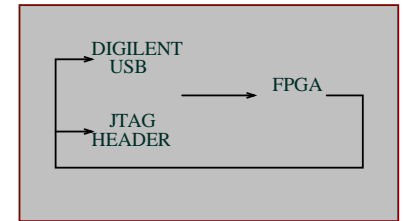

Foot F1  
Foot F2  
Foot F3  
Foot F4  
Foot F5  
Foot F6  
Foot F7  
Foot F8

Title <b>SWORD</b>		Rev <b>C.1</b> Copyright 2018
Circuit INDEX		
Doc# 500-354		
Engineer MTA		
Author GMA		
Date 1/17/2018		
Sheet# 1 out of 27		

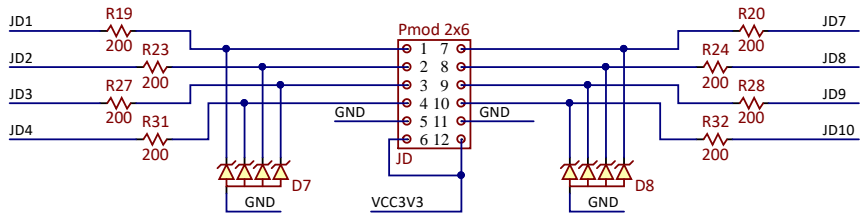
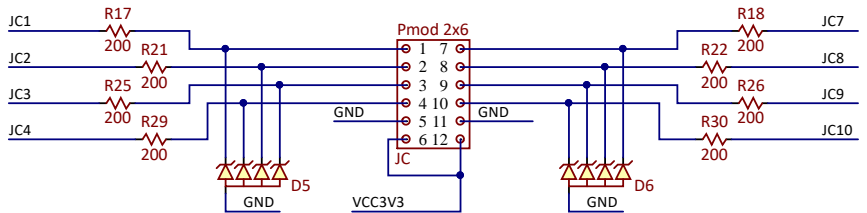
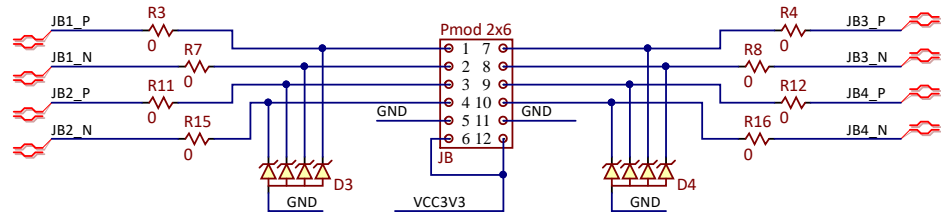
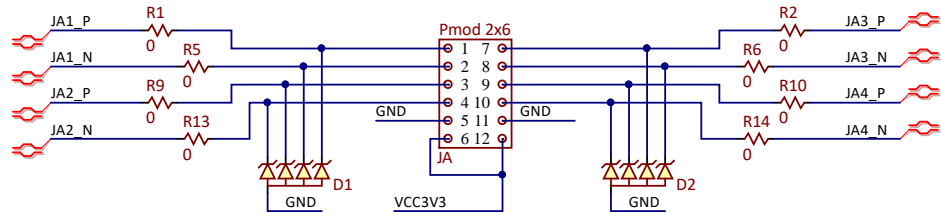

Title <b>SWORD</b>		Rev <b>C.1</b> Copyright 2018
Circuit PMods		
Doc#	500-354	
Engineer	MTA	
Author	GMA	
Date	1/17/2018	
Sheet# 2 out of 27		

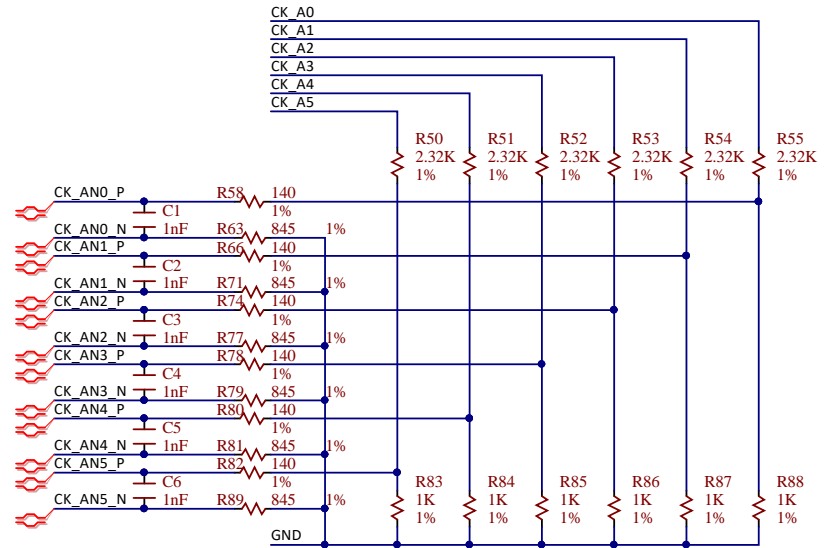
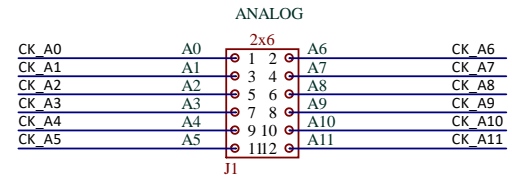
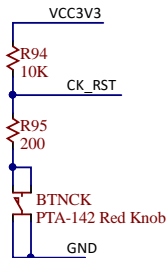
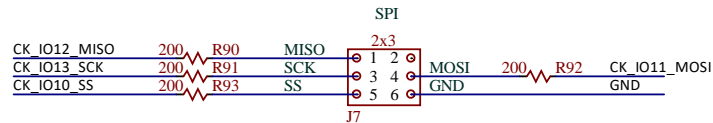
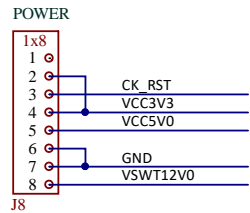
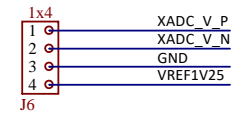
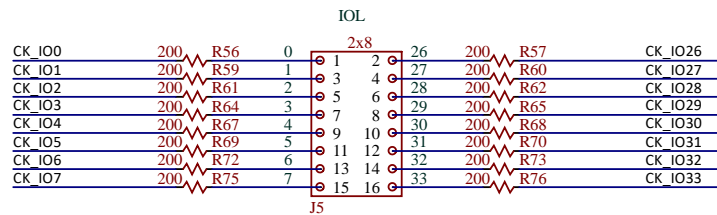
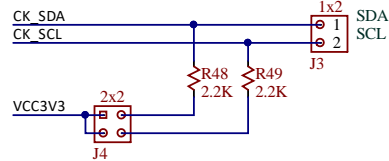
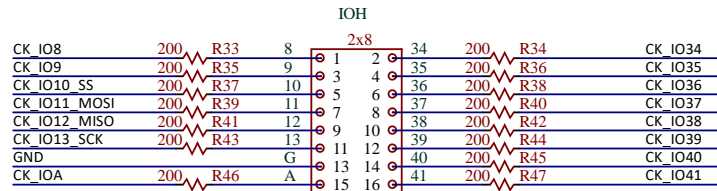

Note: Terminate N signals next to Analog Header

Title		Rev
<b>SWORD</b>		<b>C.1</b>
Circuit		Copyright 2018
CK Header		
Doc#	500-354	
Engineer	MTA	
Author	GMA	
Date	1/17/2018	
Sheet#	3 out of 27	



A

B

C

D

1

2

3

4

A

B

C

D

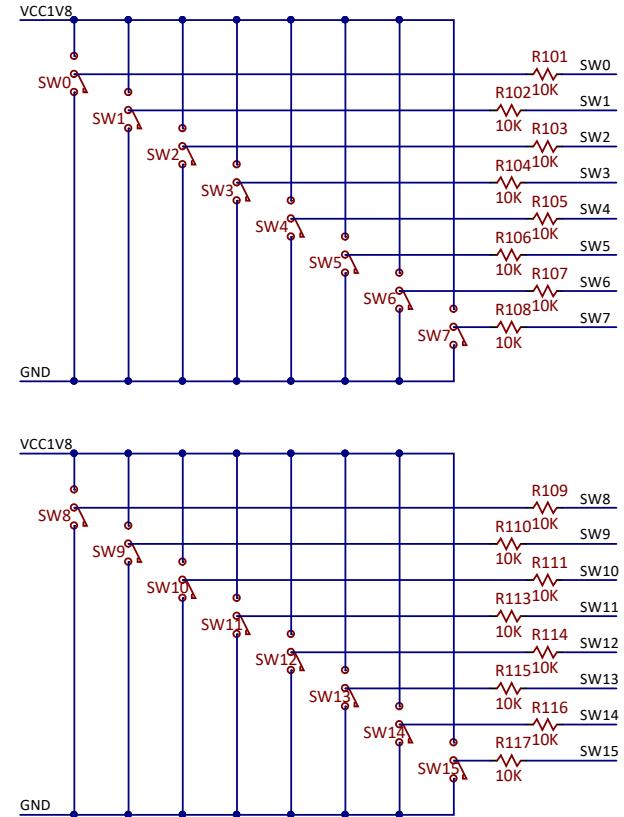
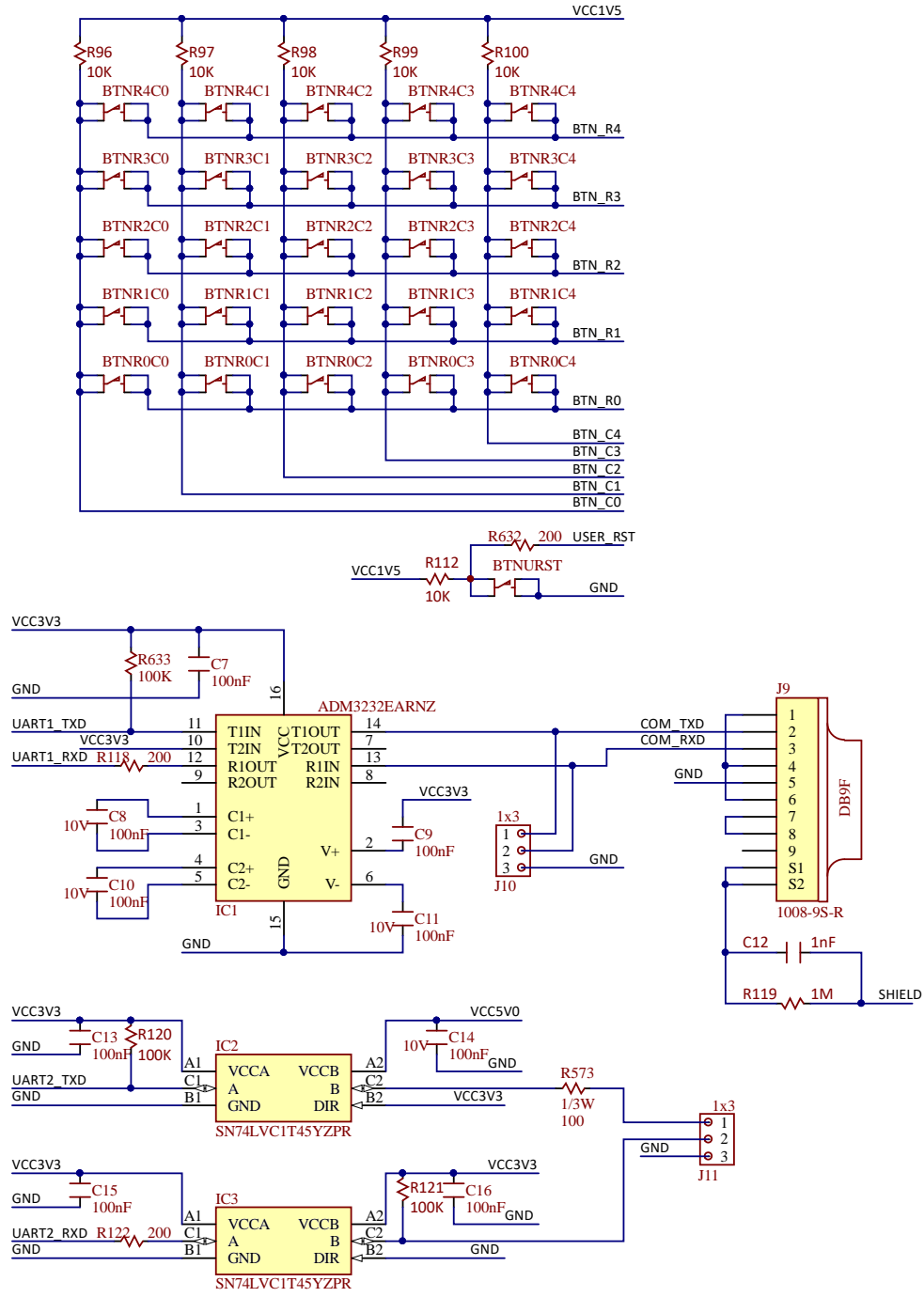

Title		Rev
<b>SWORD</b>		<b>C.1</b>
		Copyright 2018
Circuit	BTNs, SWTs, UART	
Doc#	500-354	
Engineer	MTA	
Author	GMA	
Date	1/17/2018	
Sheet#	4 out of 27	



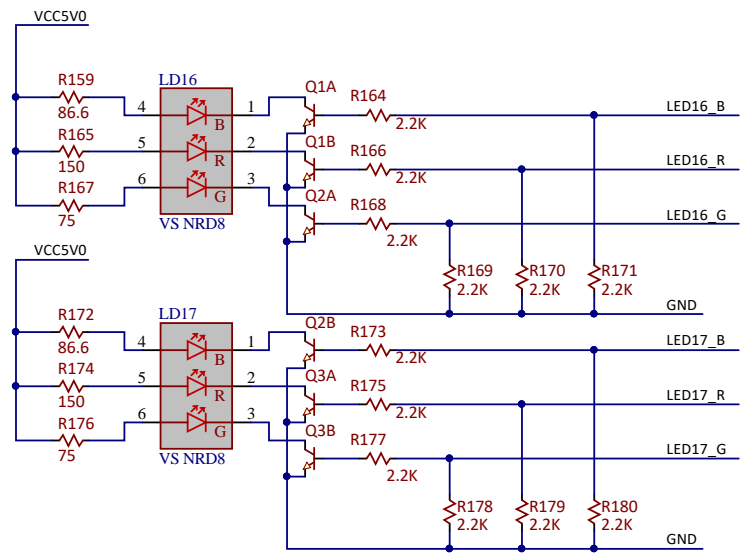
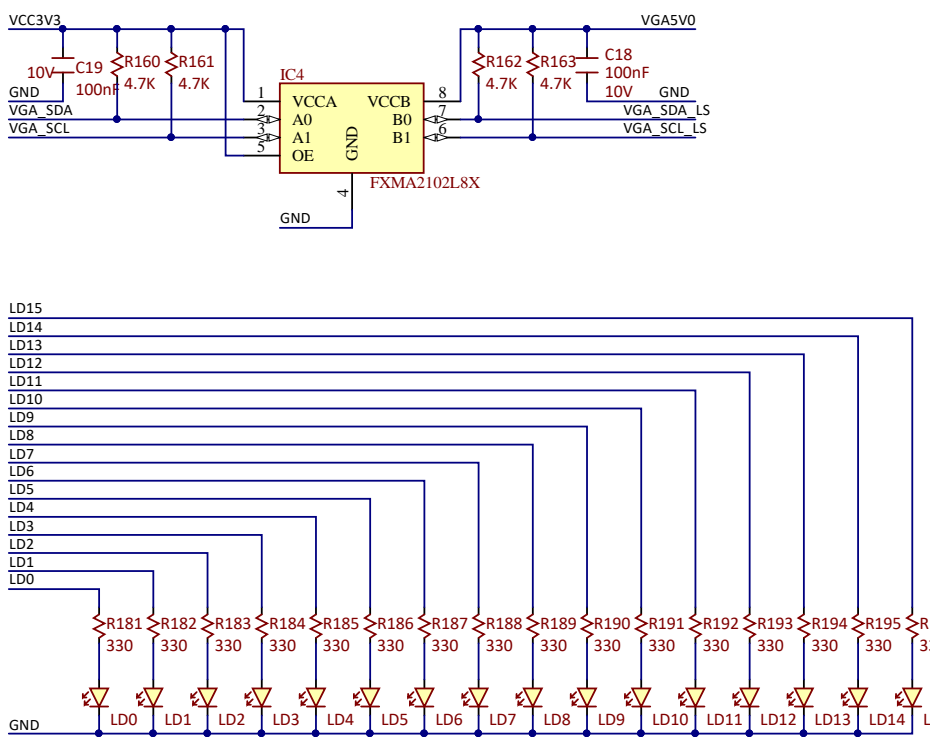
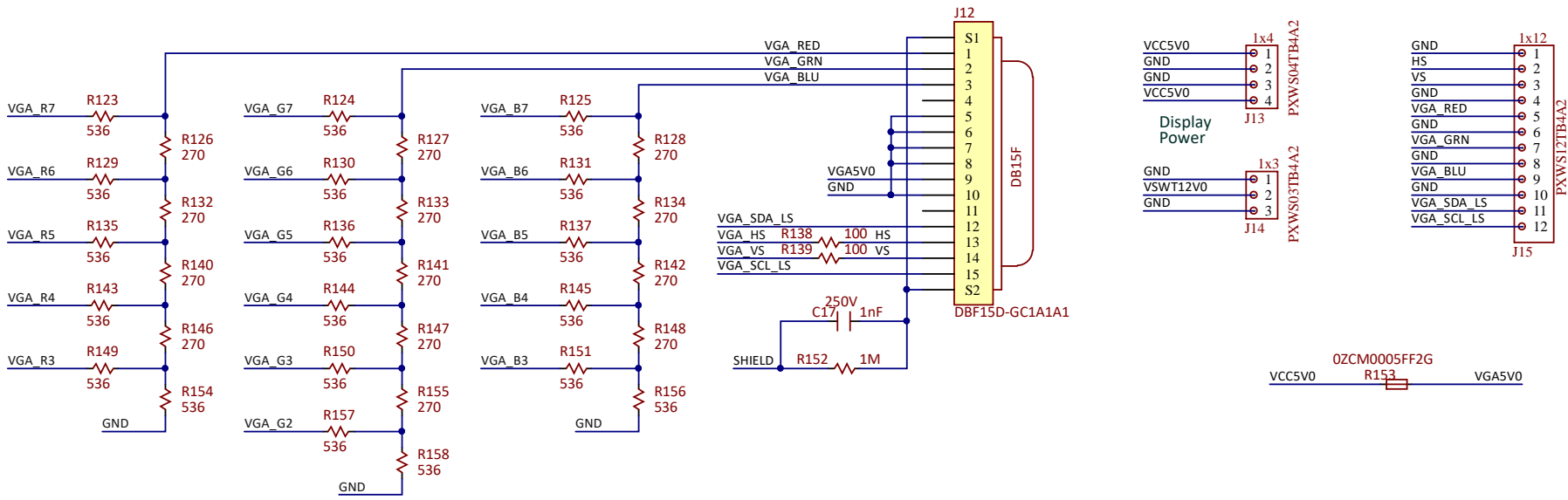

Title		Rev
<b>SWORD</b>		<b>C.1</b>
Circuit		Copyright 2018
VGA, LEDs		
Doc#	500-354	
Engineer	MTA	
Author	GMA	
Date	1/17/2018	
Sheet#	5 out of 27	



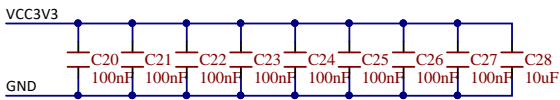
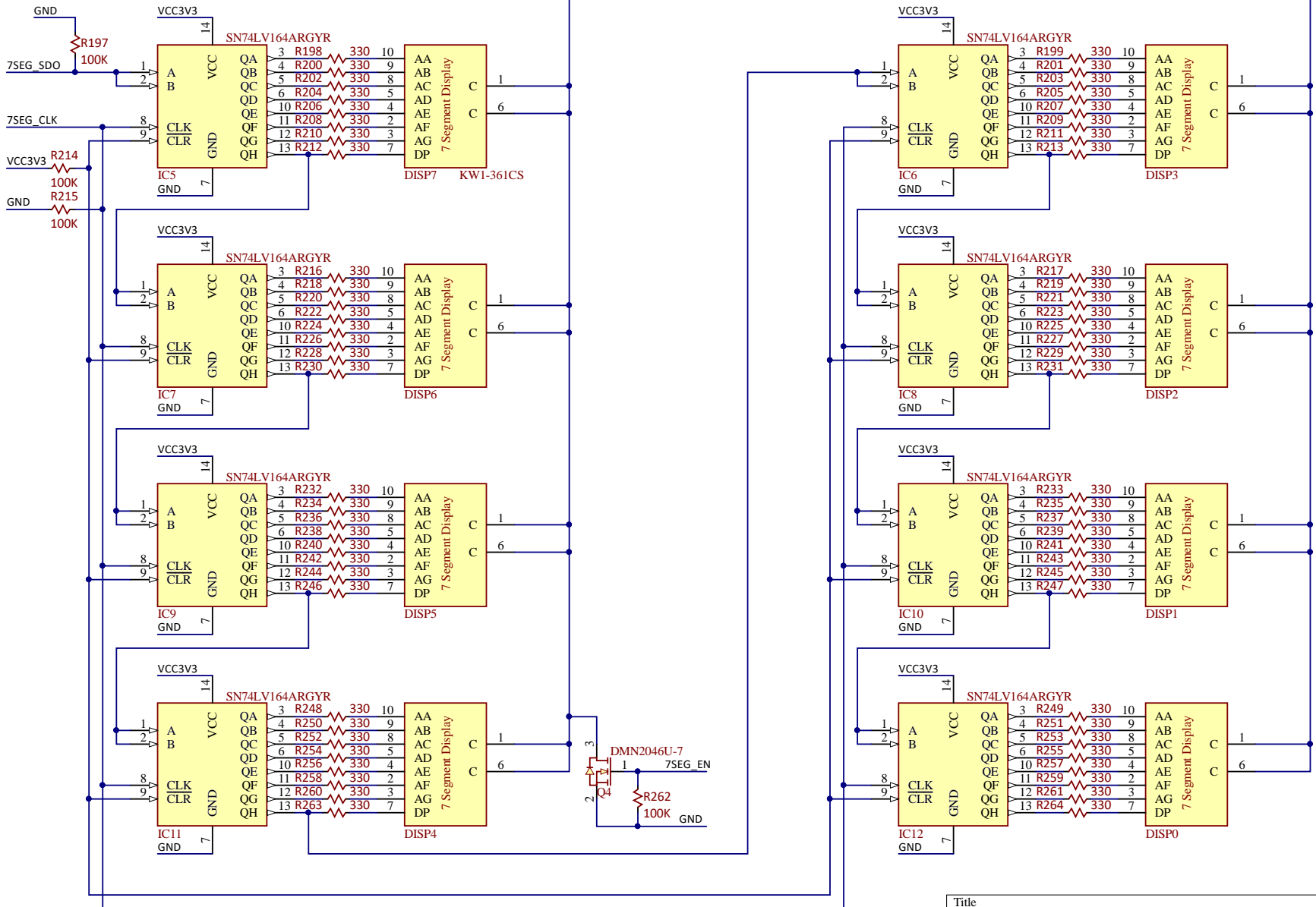

Title		Rev
<b>SWORD</b>		<b>C.1</b>
		Copyright 2018
Circuit	7SEGs	
Doc#	500-354	
Engineer	MTA	
Author	GMA	
Date	1/17/2018	
Sheet#	6 out of 27	



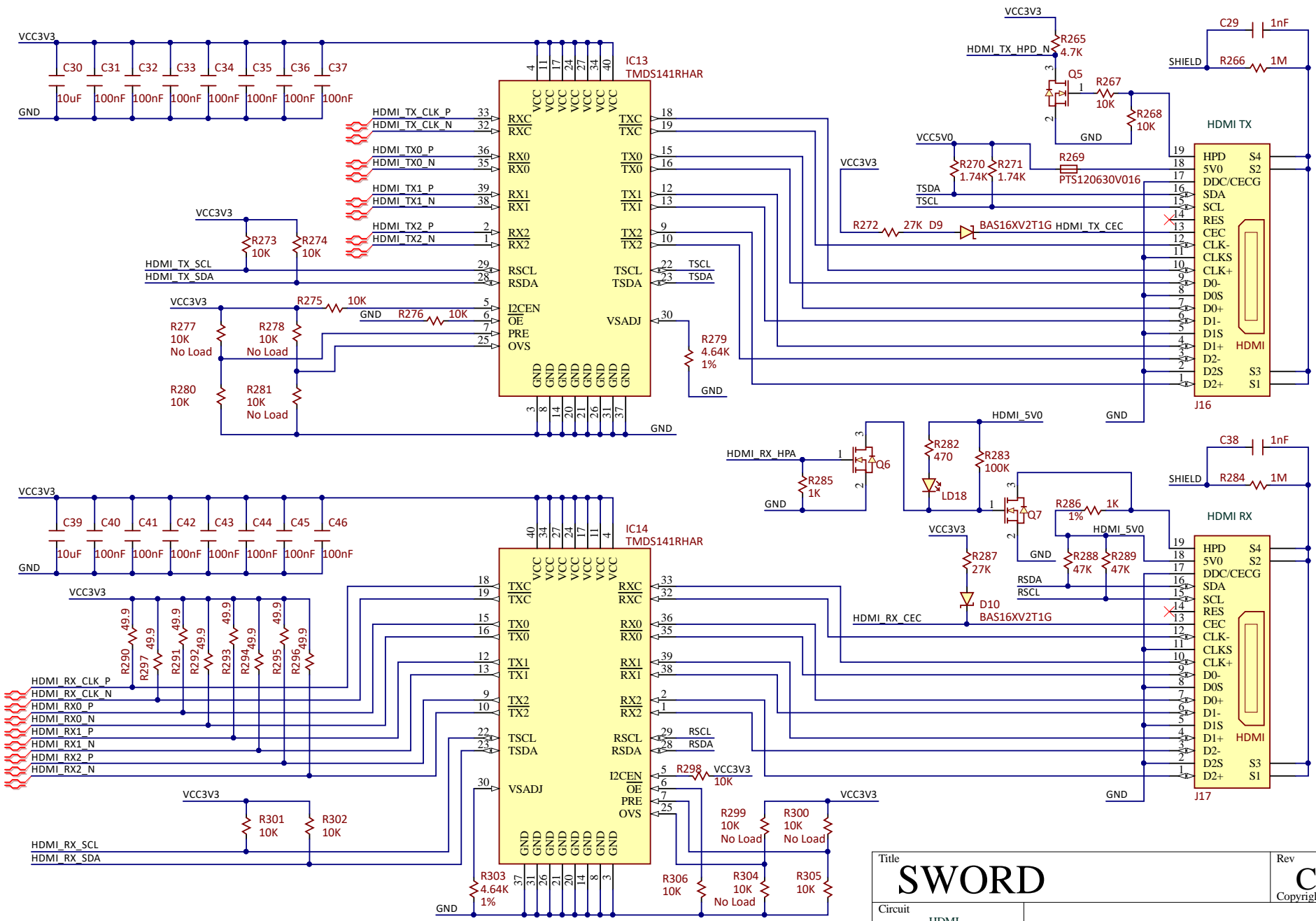

Title		Rev
<b>SWORD</b>		<b>C.1</b>
Circuit		Copyright 2018
Doc#	HDMI	
Doc#	500-354	
Engineer	MTA	
Author	GMA	
Date	1/17/2018	
Sheet#	7 out of 27	



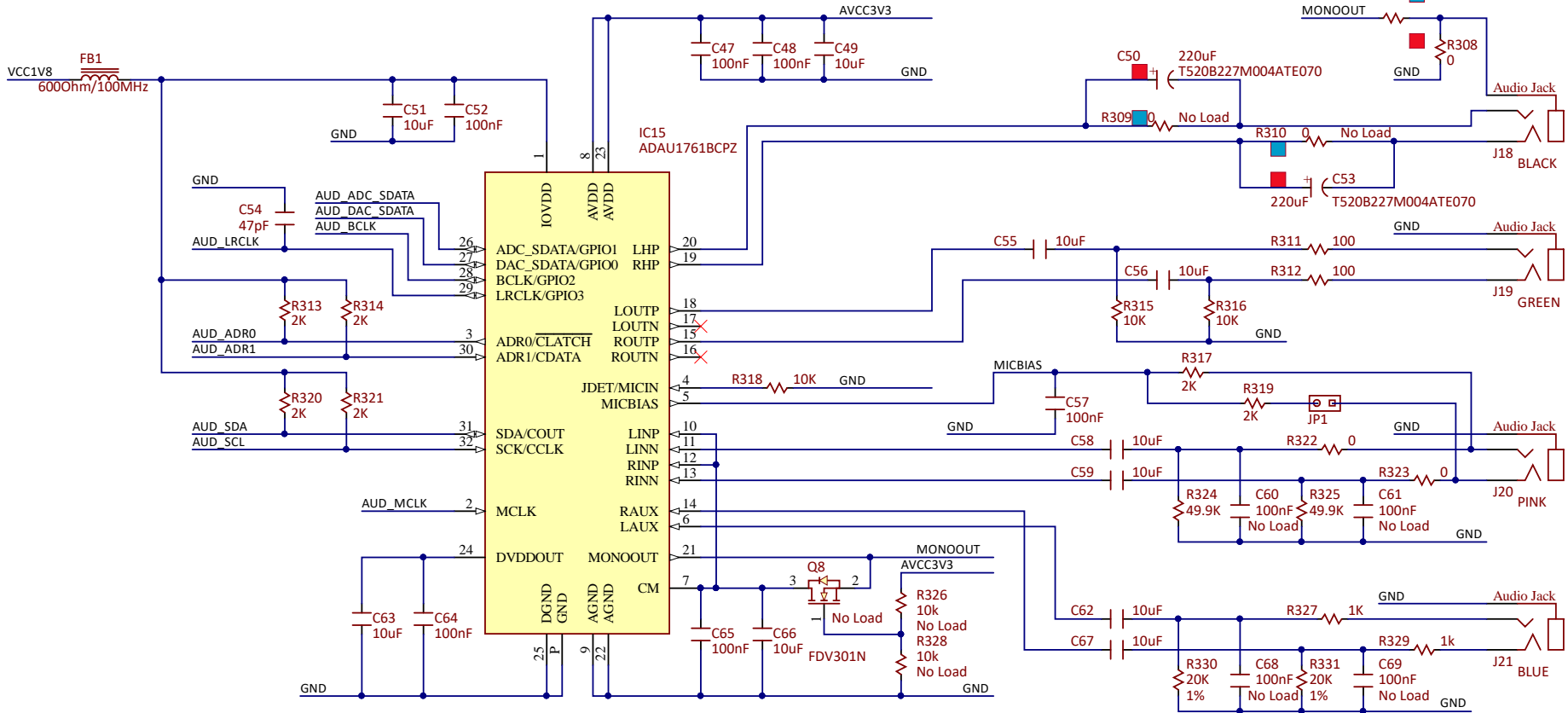

Title		Rev
<b>SWORD</b>		<b>C.1</b>
		Copyright 2018
Circuit	AUDIO	
Doc#	500-354	
Engineer	MTA	
Author	GMA	
Date	1/17/2018	
Sheet#	8 out of 27	





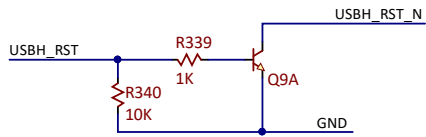
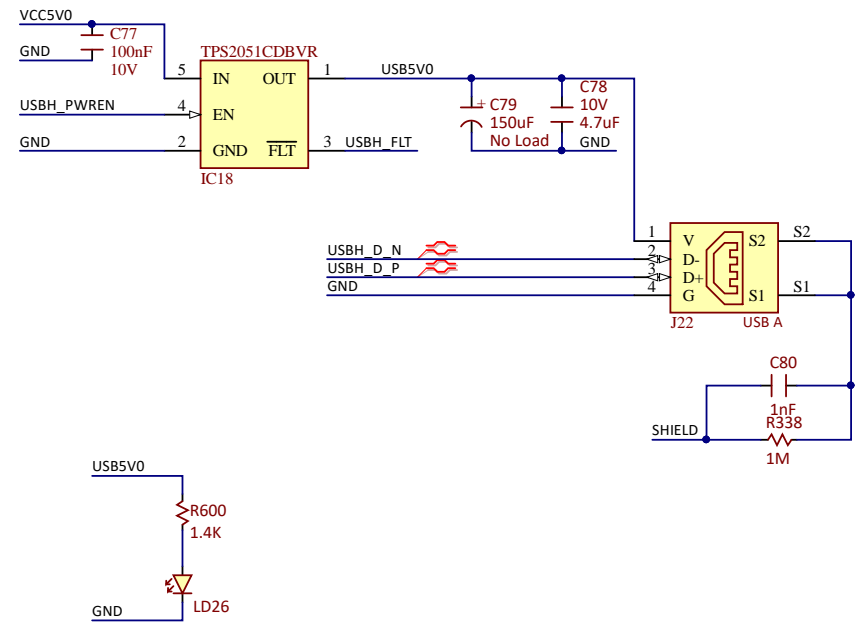
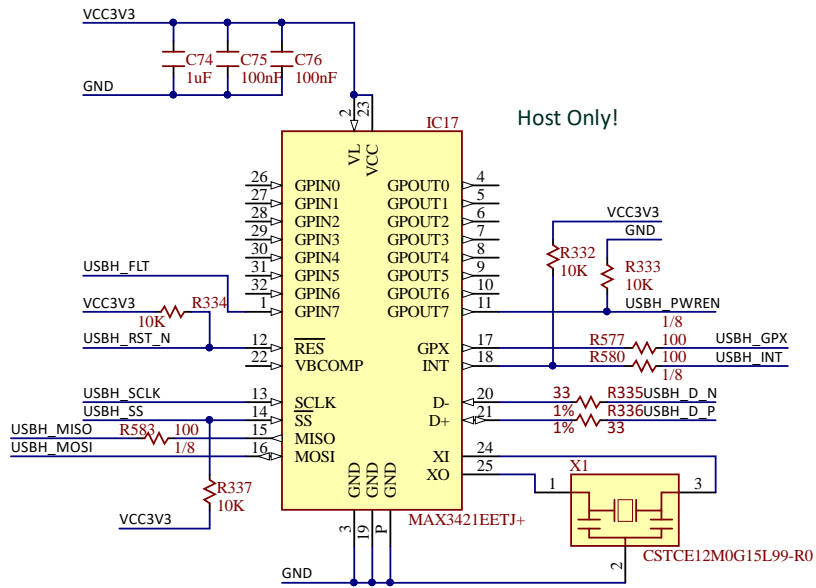

Title		Rev
<b>SWORD</b>		<b>C.1</b>
		Copyright 2018
Circuit	USB HOST	
Doc#	500-354	
Engineer	MTA	
Author	GMA	
Date	1/17/2018	
Sheet#	9 out of 27	



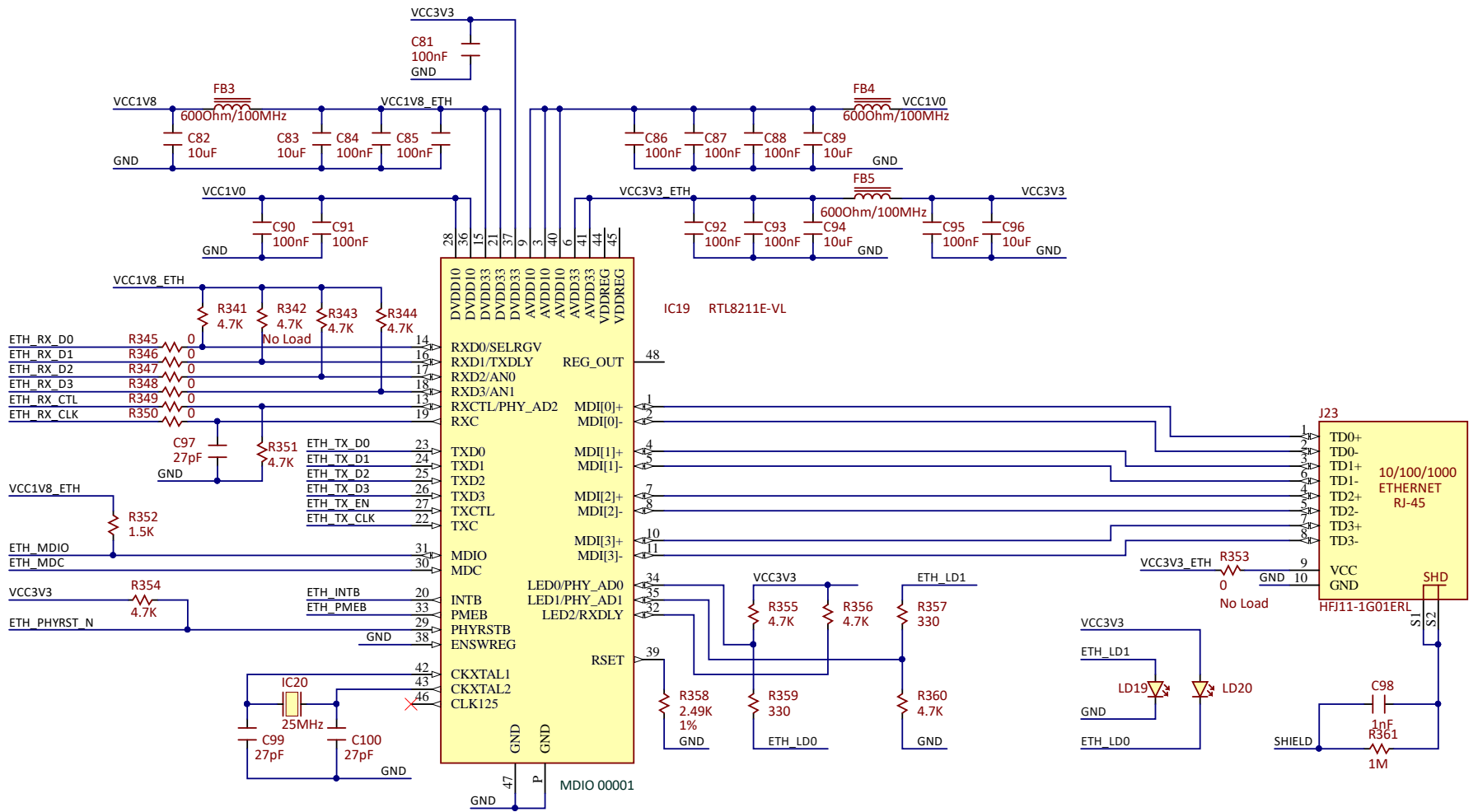

Title		Rev
<b>SWORD</b>		<b>C.1</b>
Circuit		Copyright 2018
ETHERNET		
Doc#	500-354	
Engineer	MTA	
Author	GMA	
Date	1/17/2018	
Sheet#	10 out of 27	



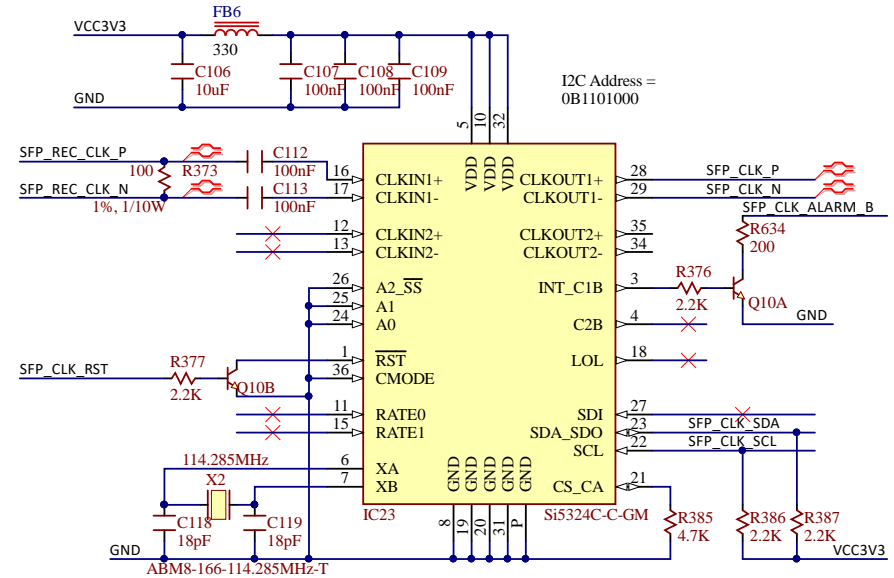
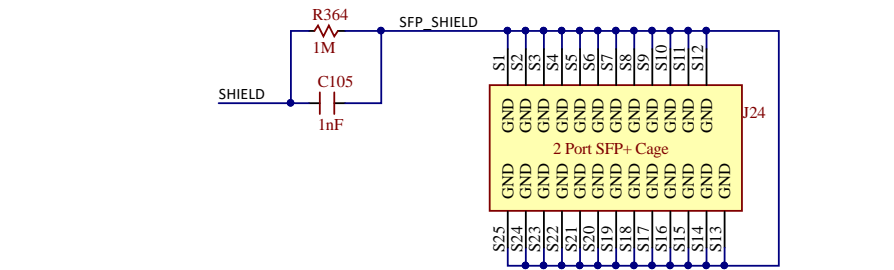
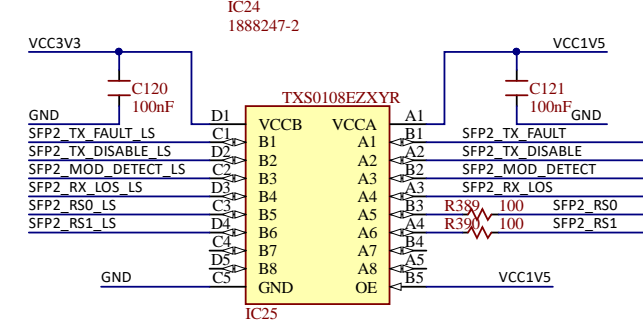
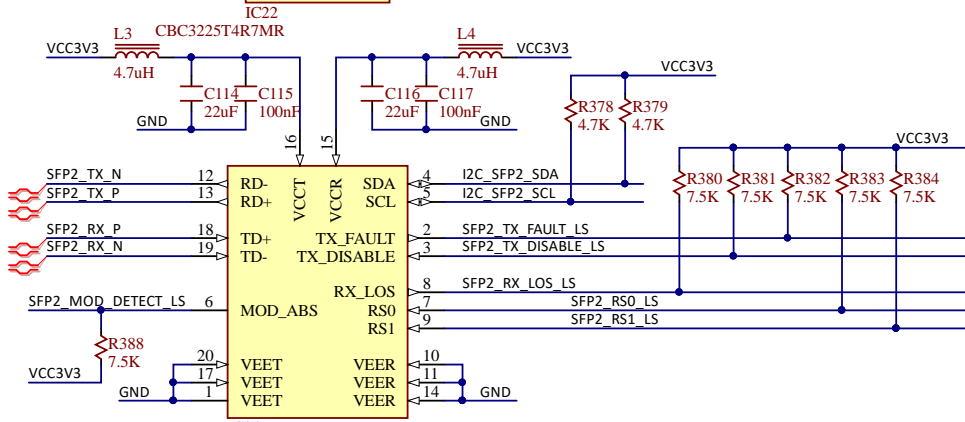
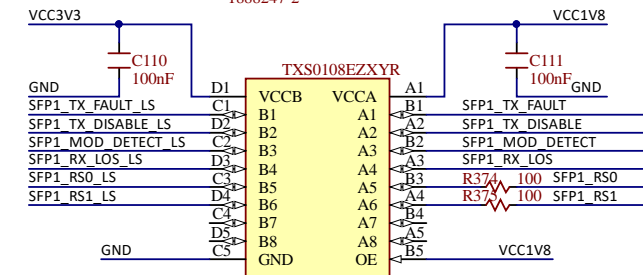
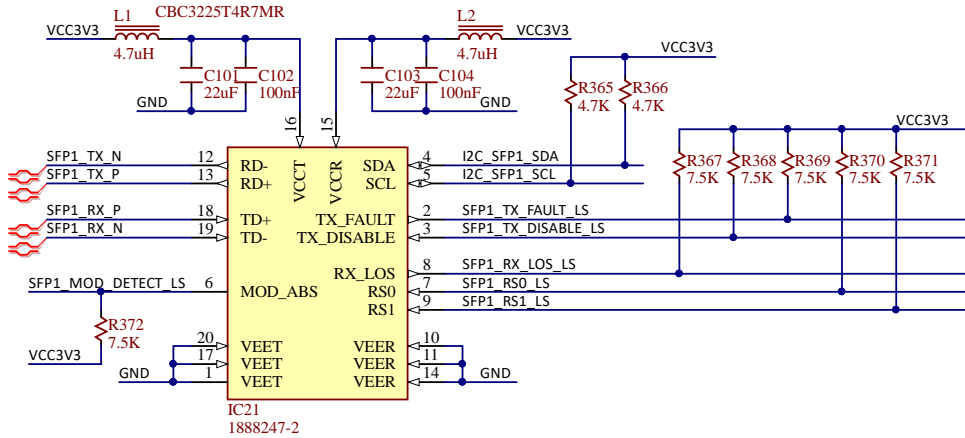

Title		Rev
<b>SWORD</b>		<b>C.1</b>
		Copyright 2018
Circuit	SFPs	
Doc#	500-354	
Engineer	MTA	
Author	GMA	
Date	1/17/2018	
Sheet#	11 out of 27	



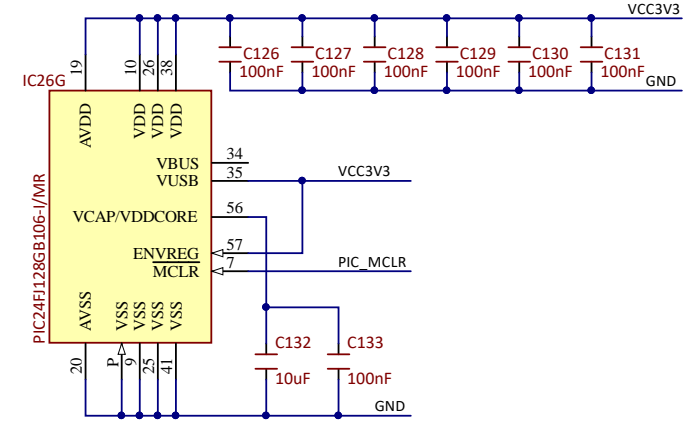
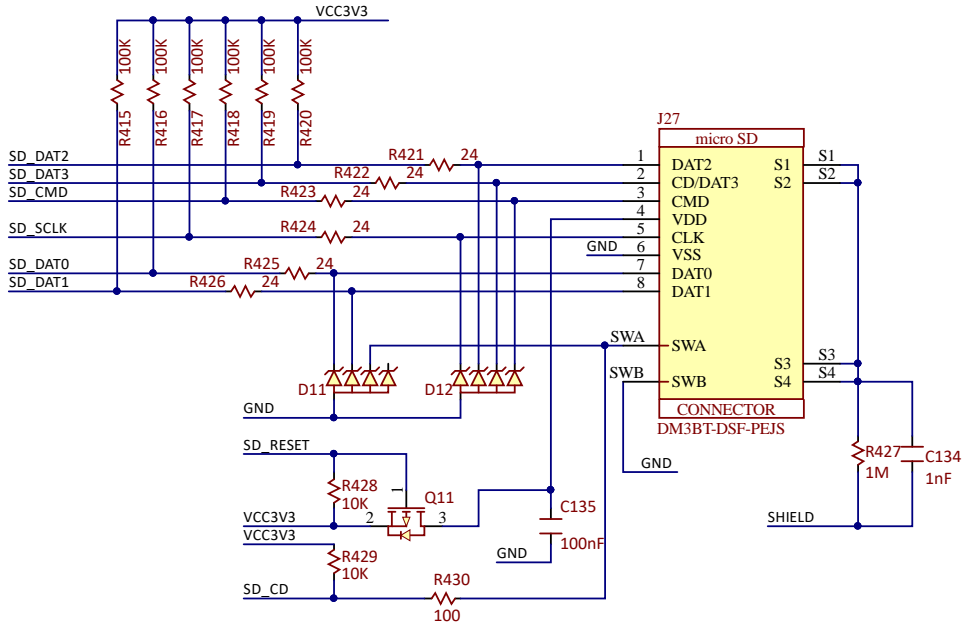
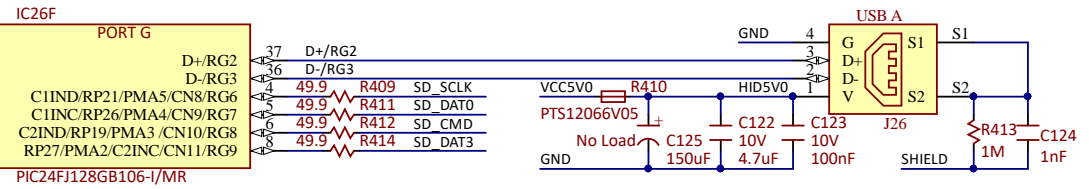
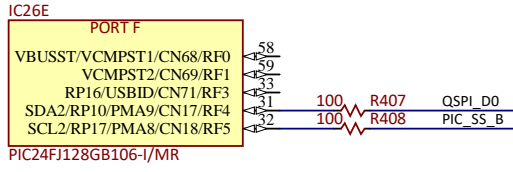
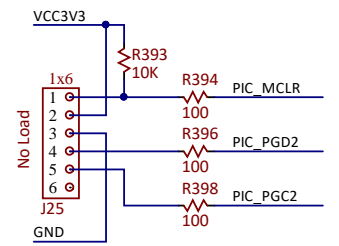
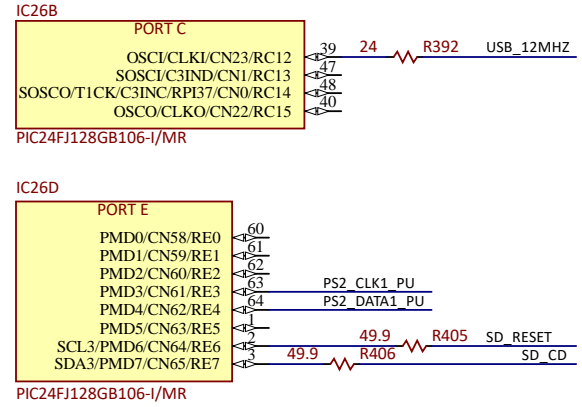
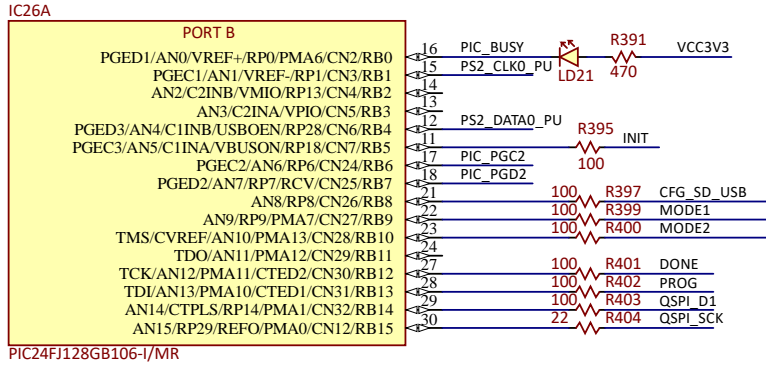

Title		Rev
<b>SWORD</b>		<b>C.1</b>
Circuit		Copyright 2018
USB HID, SD CARD		
Doc#	500-354	
Engineer	MTA	
Author	GMA	
Date	1/17/2018	
Sheet#	12 out of 27	

1

2

3

4

A

A

B

B

C

C

D

D

This page intentionally left blank.

Title		Rev	
<b>SWORD</b>		<b>C.1</b>	
Circuit		Copyright 2018	
USB PROG / UART			
Doc#	500-354		
Engineer	MTA		
Author	GMA		
Date	1/17/2018		
Sheet#	13 out of 27		



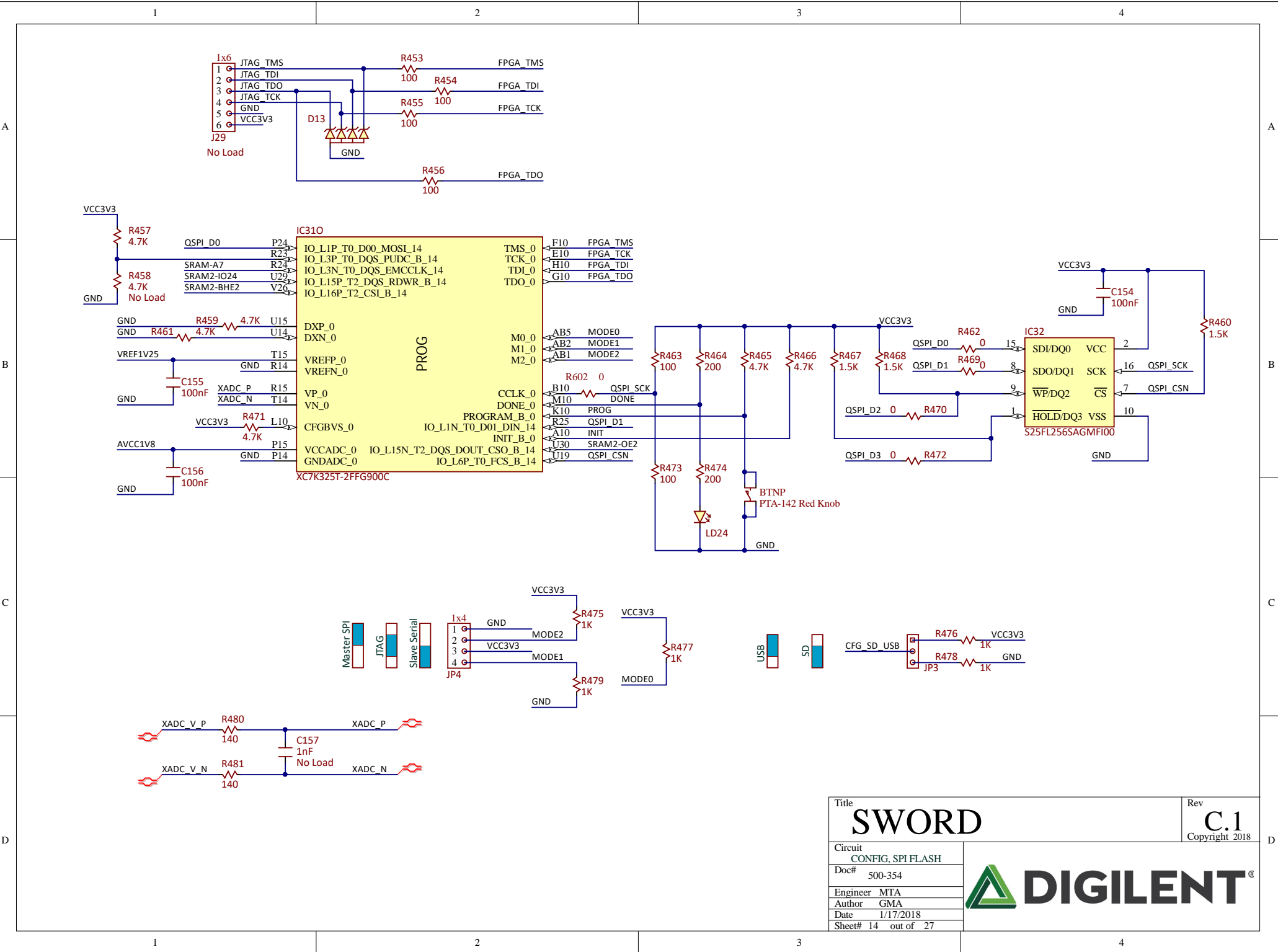

Title <b>SWORD</b>		Rev <b>C.1</b> Copyright 2018
Circuit CONFIG, SPI FLASH		
Doc# 500-354		
Engineer MTA		
Author GMA		
Date 1/17/2018		
Sheet# 14 out of 27		



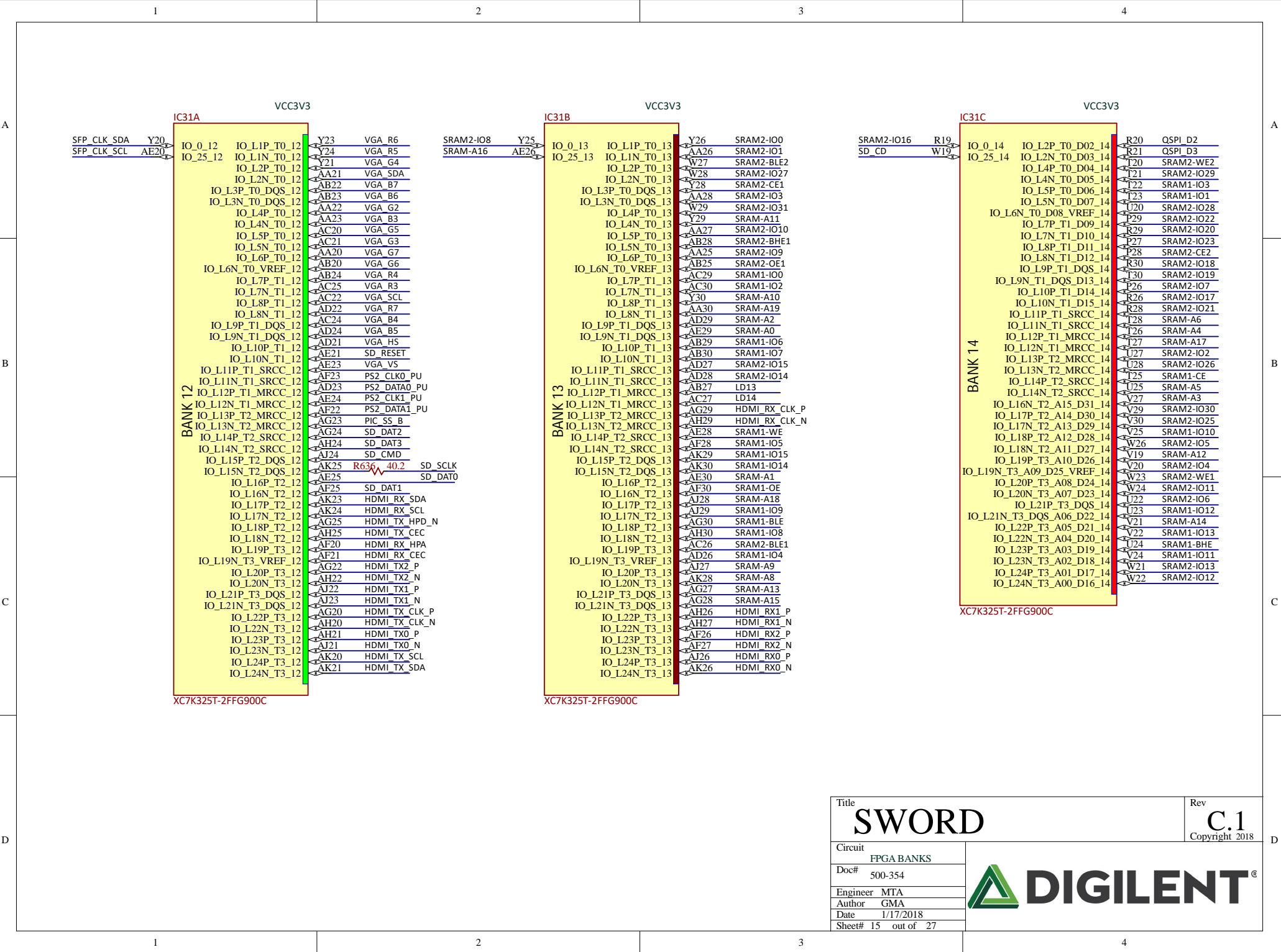

Title <b>SWORD</b>		Rev <b>C.1</b> Copyright 2018
Circuit FPGA BANKS		
Doc# 500-354		
Engineer MTA		
Author GMA		
Date 1/17/2018		
Sheet# 15 out of 27		



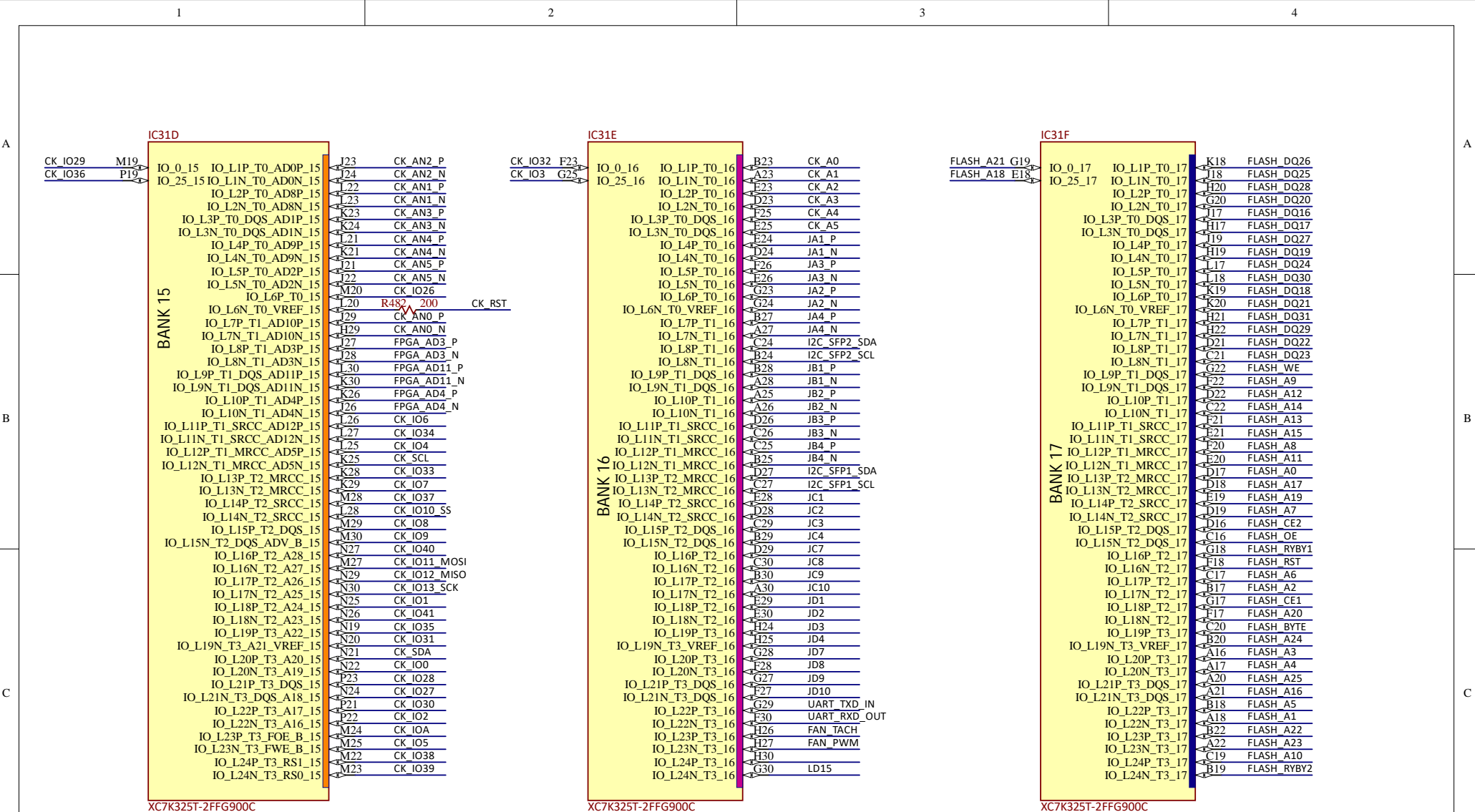

XC7K325T-2FFG900C

XC7K325T-2FFG900C

XC7K325T-2FFG900C

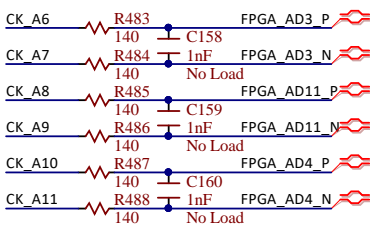

Title <b>SWORD</b>		Rev <b>C.1</b> Copyright 2018
Circuit FPGA BANKS		
Doc# 500-354		
Engineer MTA		
Author GMA		
Date 1/17/2018		
Sheet# 16 out of 27		





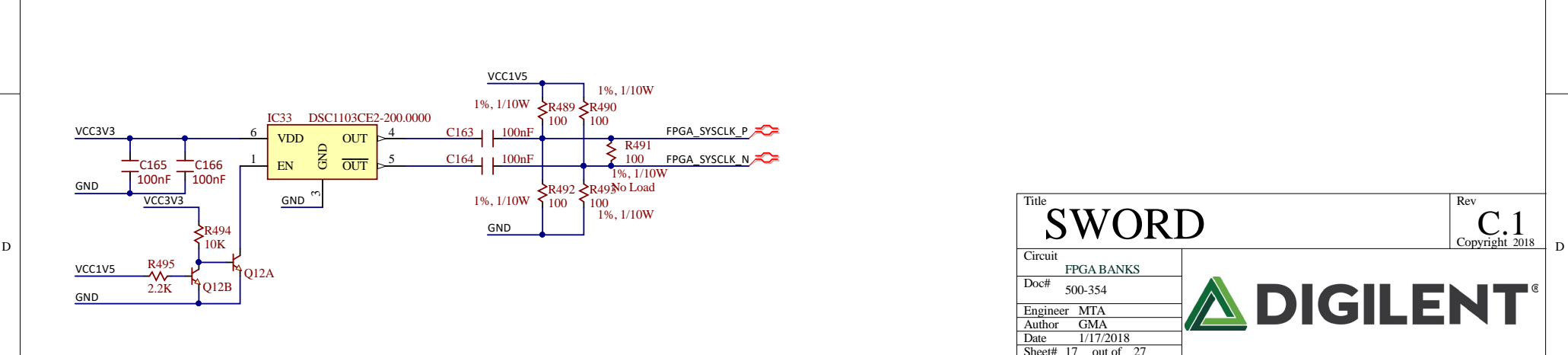
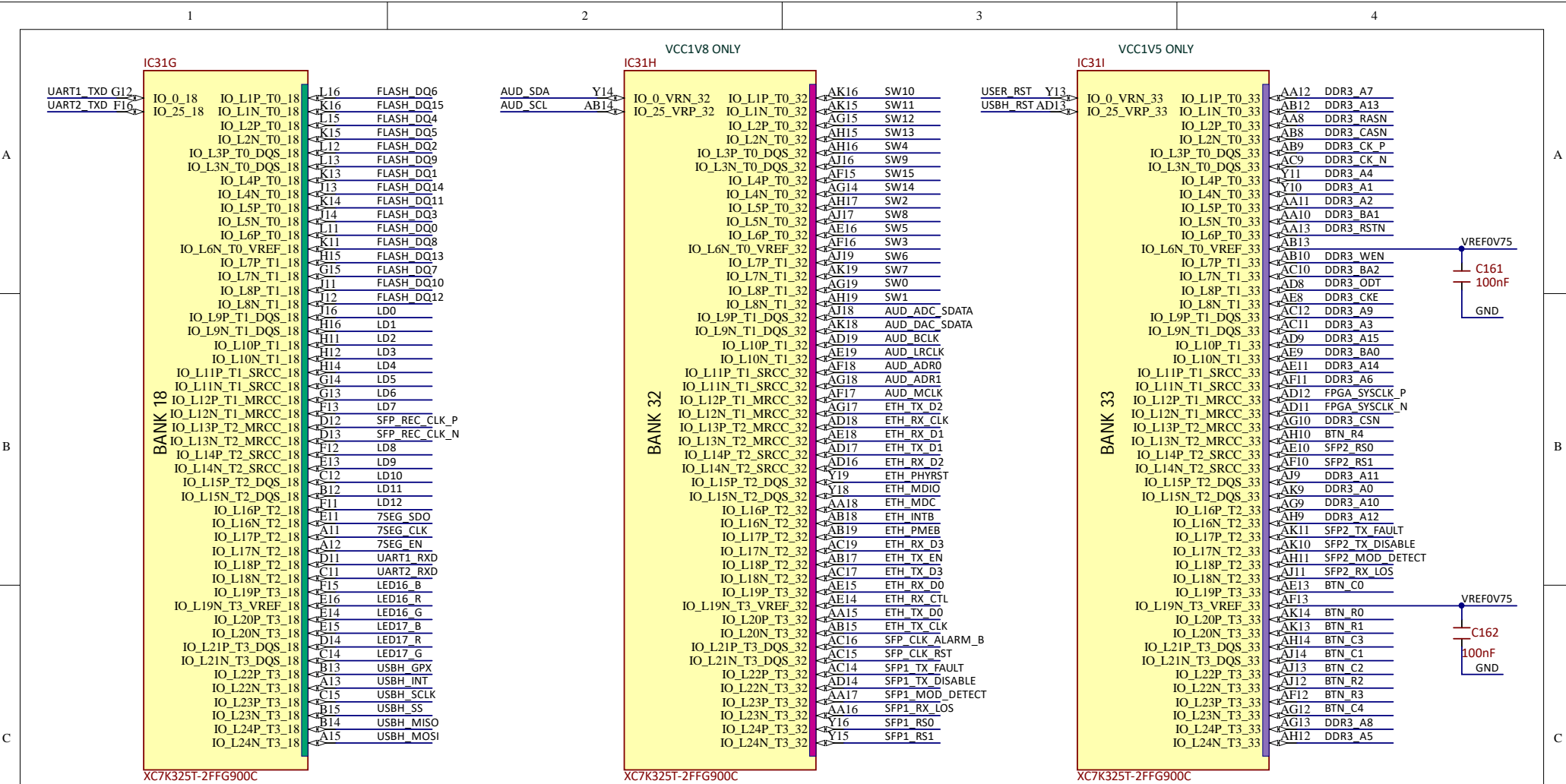

Title <b>SWORD</b>		Rev <b>C.1</b>
Circuit FPGA BANKS		Copyright 2018
Doc# 500-354	Engineer MTA	
Author GMA	Date 1/17/2018	
Date 1/17/2018	Sheet# 17 out of 27	
Sheet# 17 out of 27		

VCC1V5 ONLY

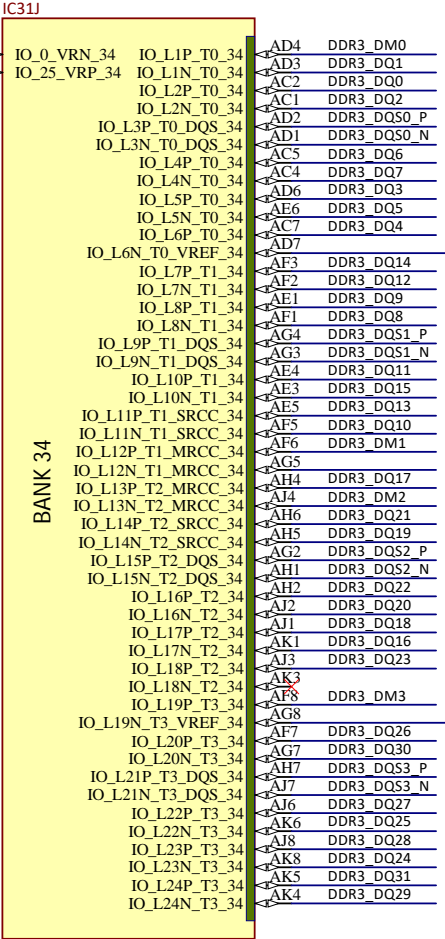
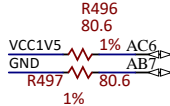

XC7K325T-2FFG900C

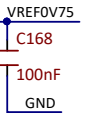
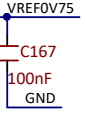

IC31K

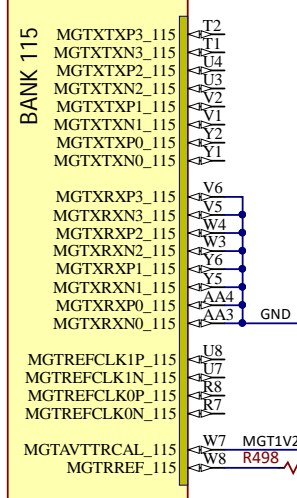

XC7K325T-2FFG900C

IC31M

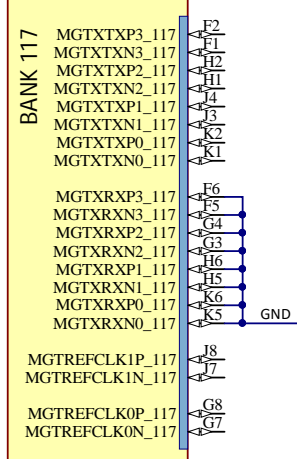

XC7K325T-2FFG900C

3

IC31L

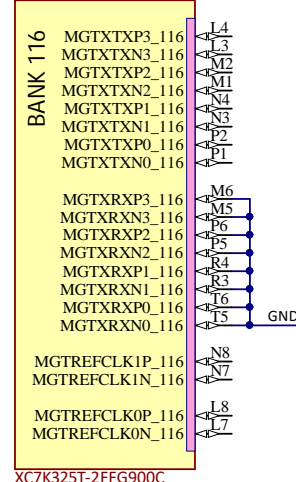

XC7K325T-2FFG900C

IC31N

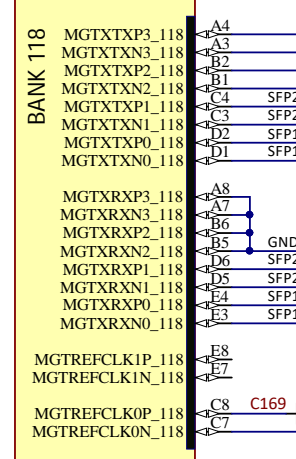

XC7K325T-2FFG900C

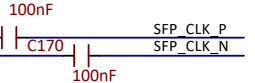

Title <b>SWORD</b>		Rev <b>C.1</b> Copyright 2018
Circuit FPGA BANKS	Doc# 500-354	
Engineer MTA	Author GMA	
Date 1/17/2018	Sheet# 18 out of 27	

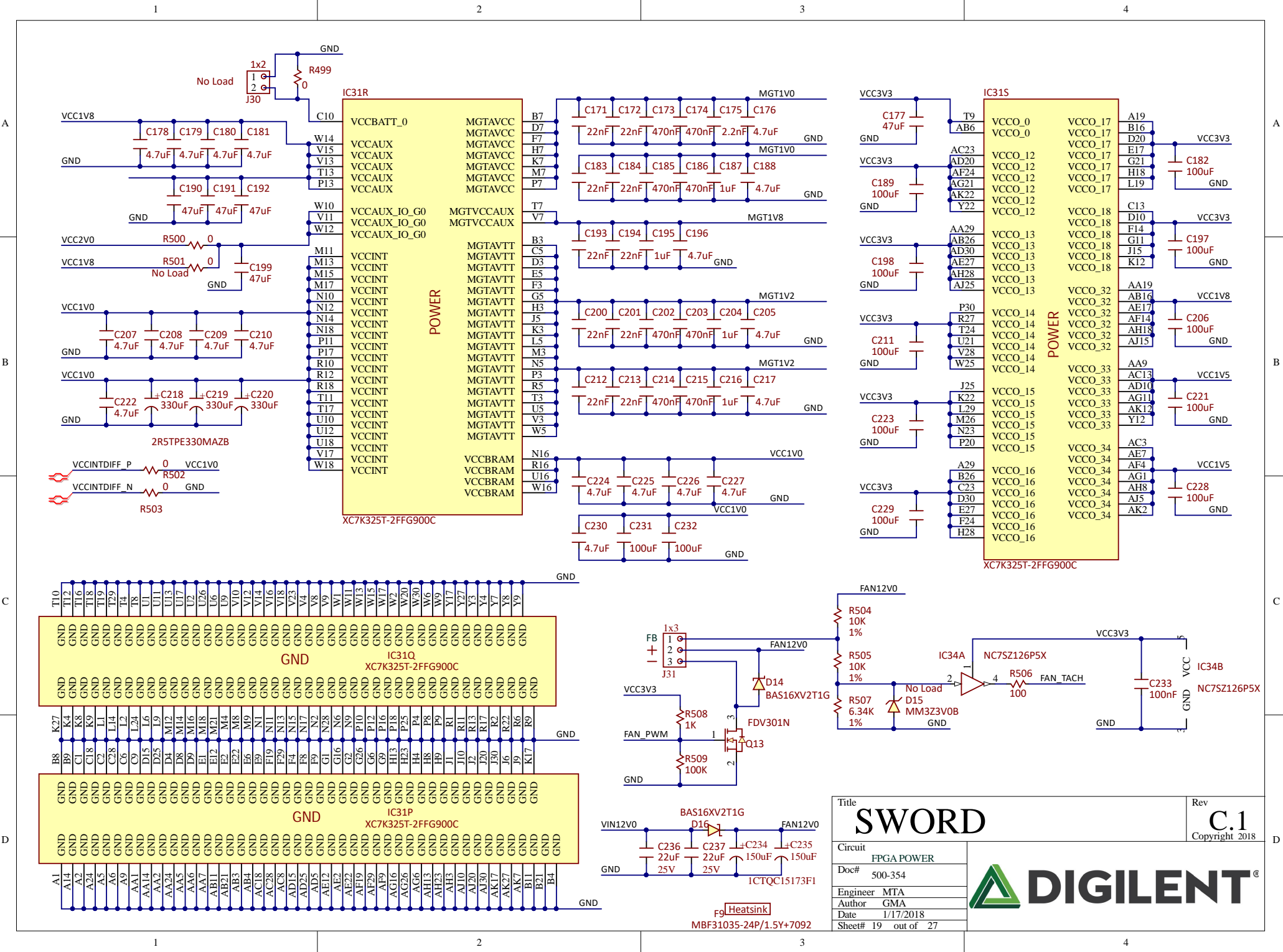

Title		Rev
<b>SWORD</b>		<b>C.1</b>
Circuit		Copyright 2018
FPGA POWER		
Doc#	500-354	
Engineer	MTA	
Author	GMA	
Date	1/17/2018	
Sheet#	19 out of 27	



MBF31035-24P/1.5V+7092

A

A

B

B

C

C

D

D

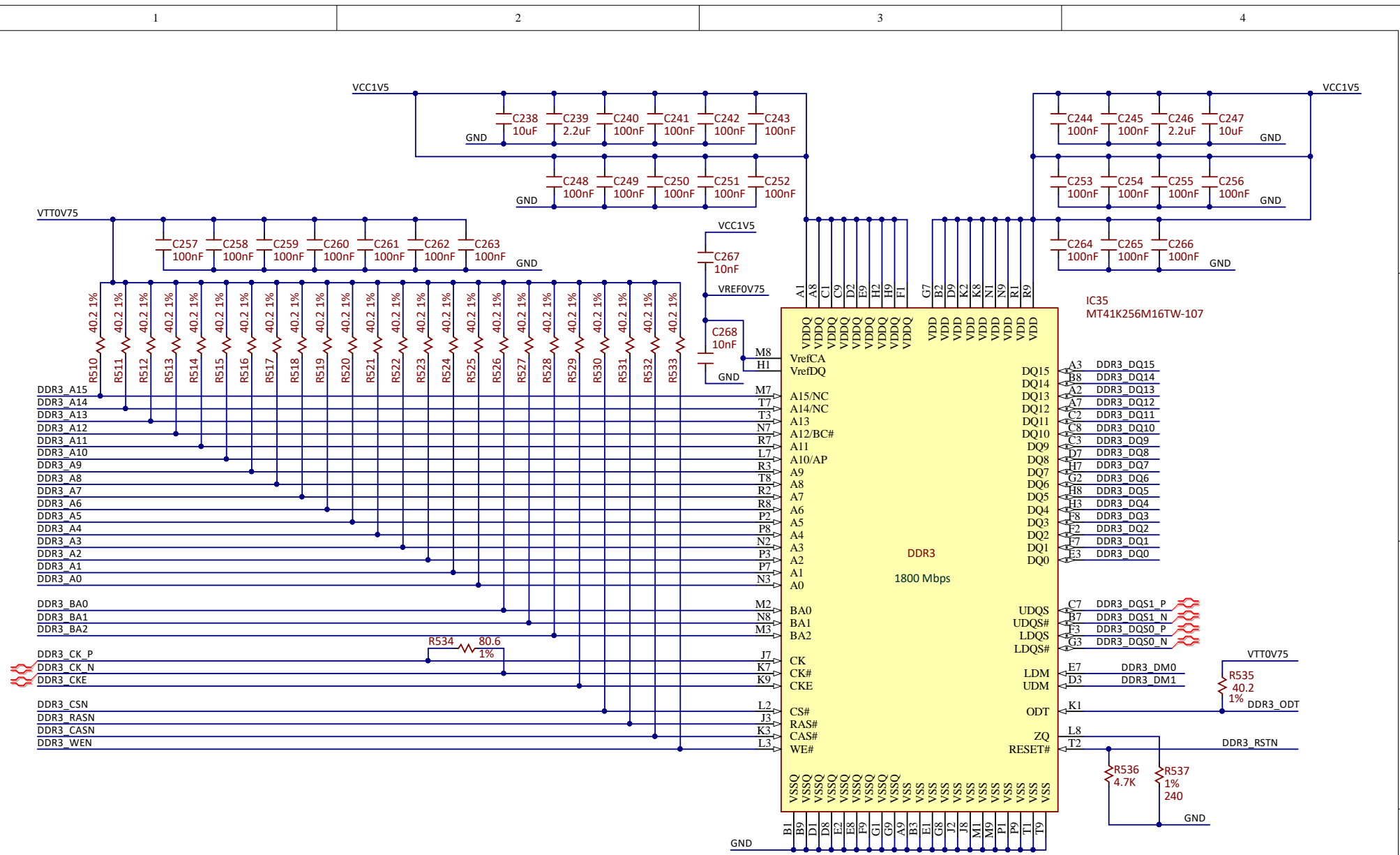

Title		Rev
<b>SWORD</b>		<b>C.1</b>
		Copyright 2018
Circuit	DDR3	
Doc#	500-354	
Engineer	MTA	
Author	GMA	
Date	1/17/2018	
Sheet#	20 out of 27	



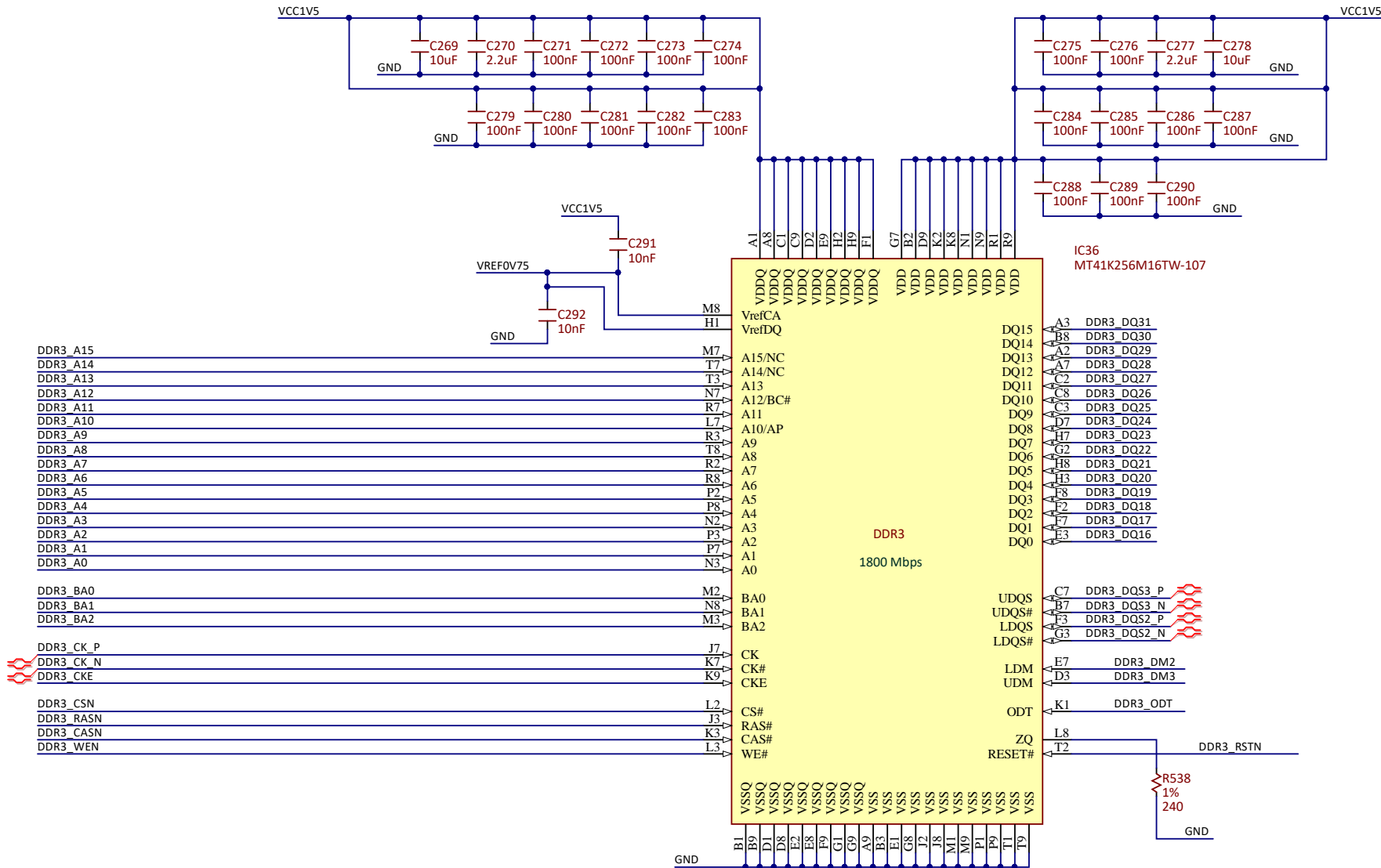

Title		Rev
<b>SWORD</b>		<b>C.1</b>
		Copyright 2018
Circuit	DDR3	
Doc#	500-354	
Engineer	MTA	
Author	GMA	
Date	1/17/2018	
Sheet#	21 out of 27	



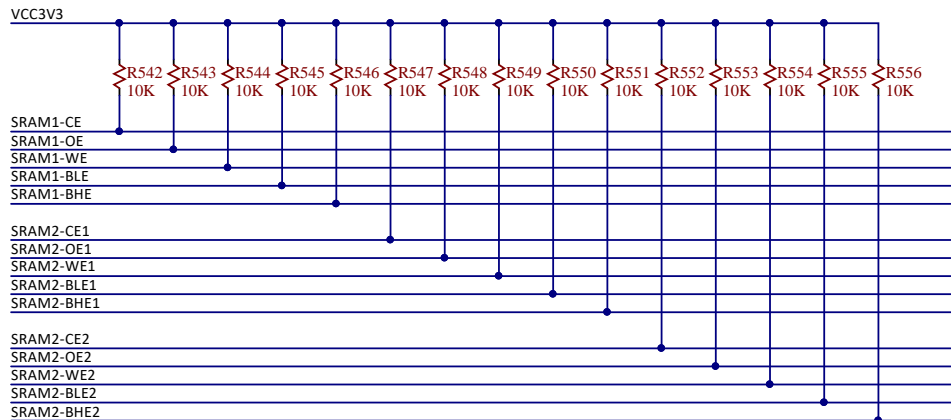
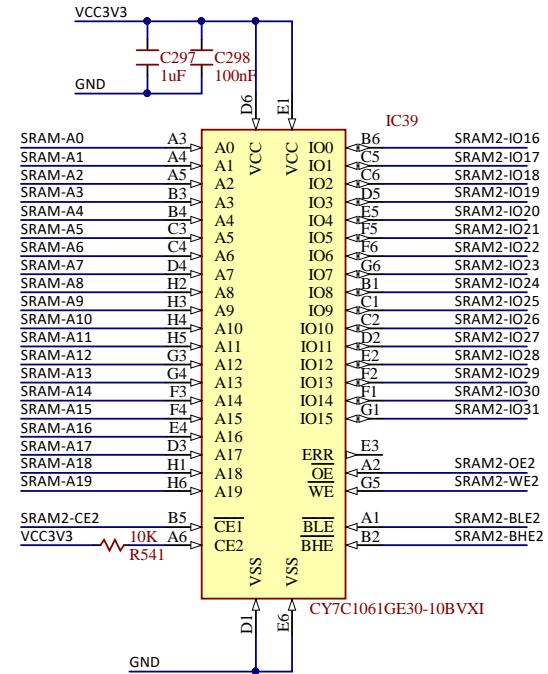
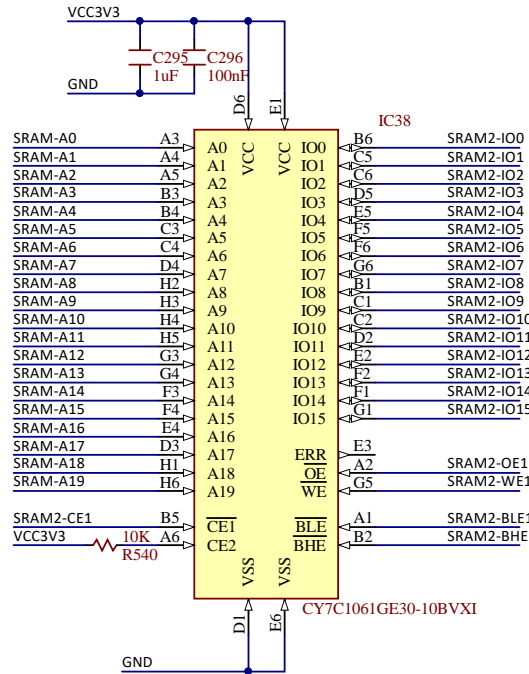
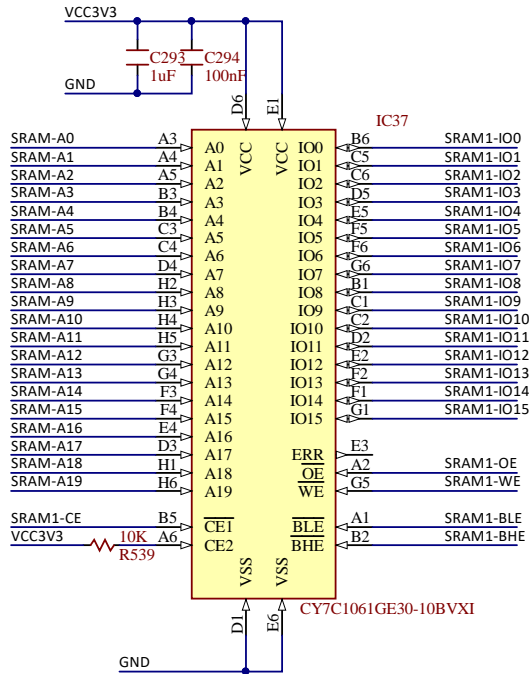

Title <b>SWORD</b>		Rev <b>C.1</b> Copyright 2018
Circuit	STATIC RAM	
Doc#	500-354	
Engineer	MTA	
Author	GMA	
Date	1/17/2018	
Sheet#	22 out of 27	



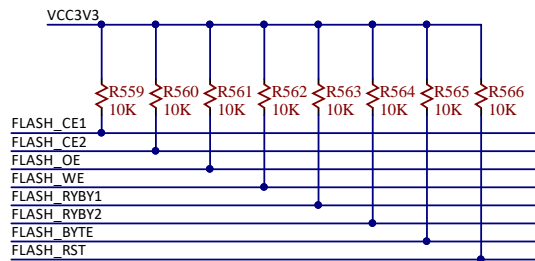
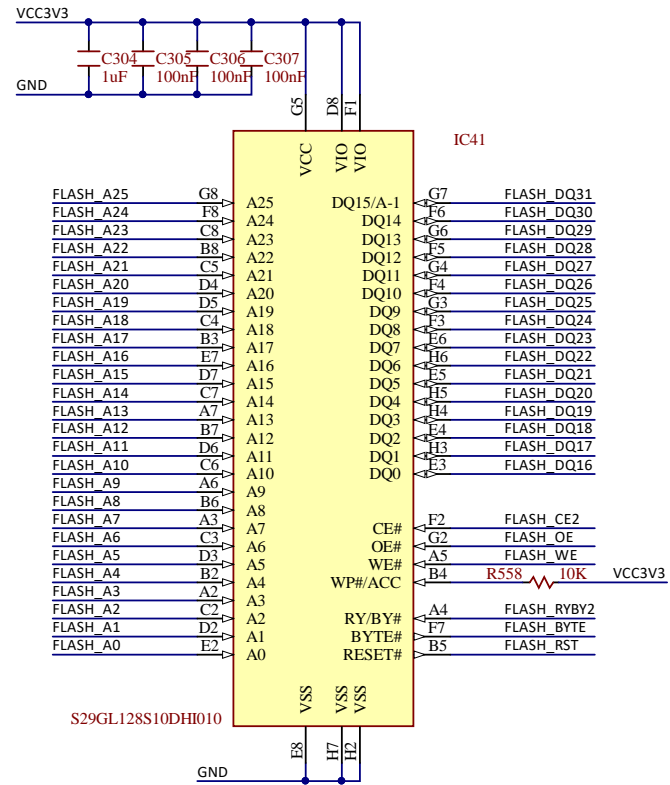
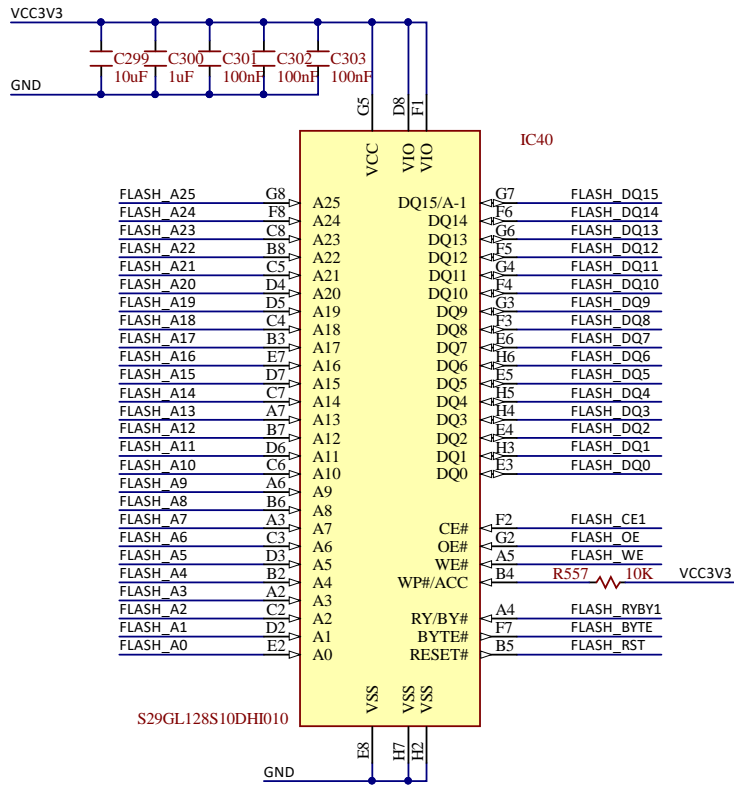

Title		Rev
<b>SWORD</b>		<b>C.1</b>
		Copyright 2018
Circuit	Page Flash	
Doc#	500-354	
Engineer	MTA	
Author	GMA	
Date	1/17/2018	
Sheet#	23 out of 27	



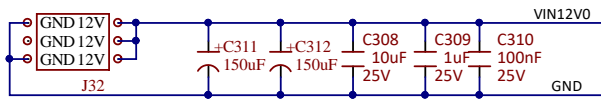

Under Barrel Jack

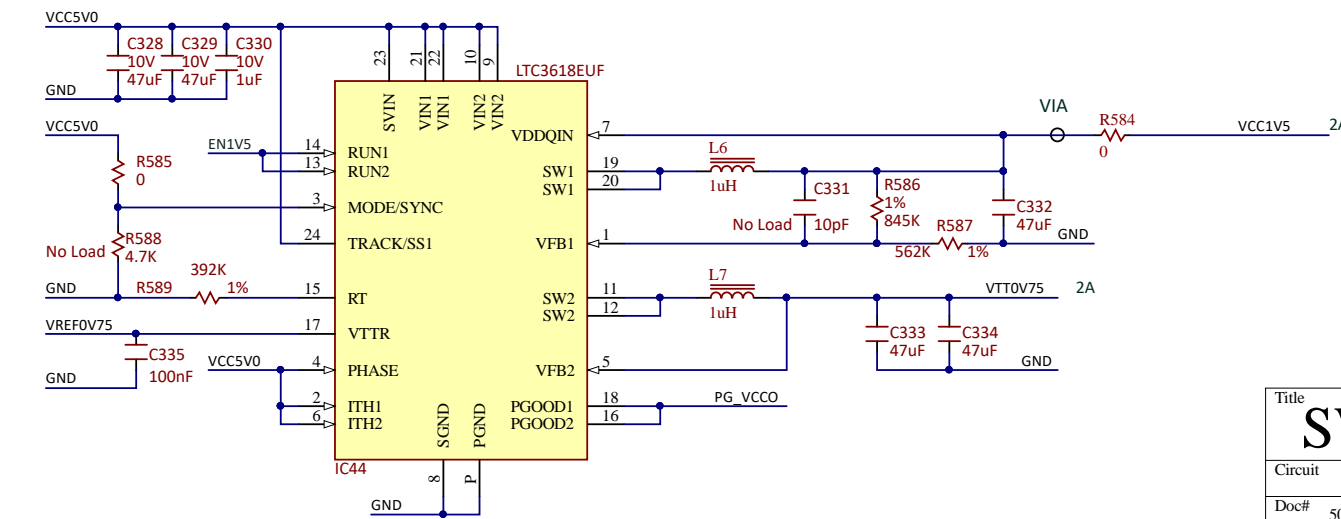
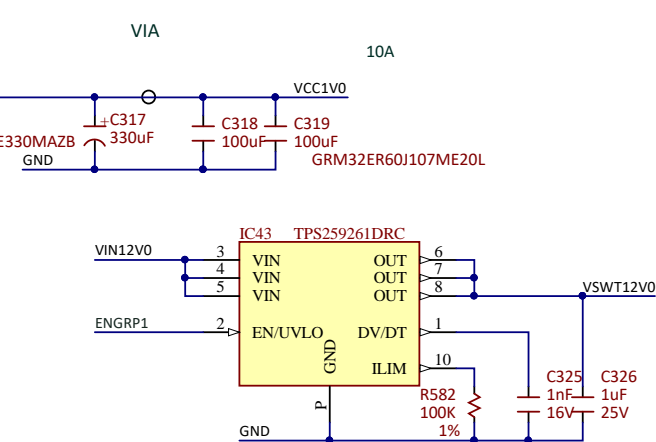
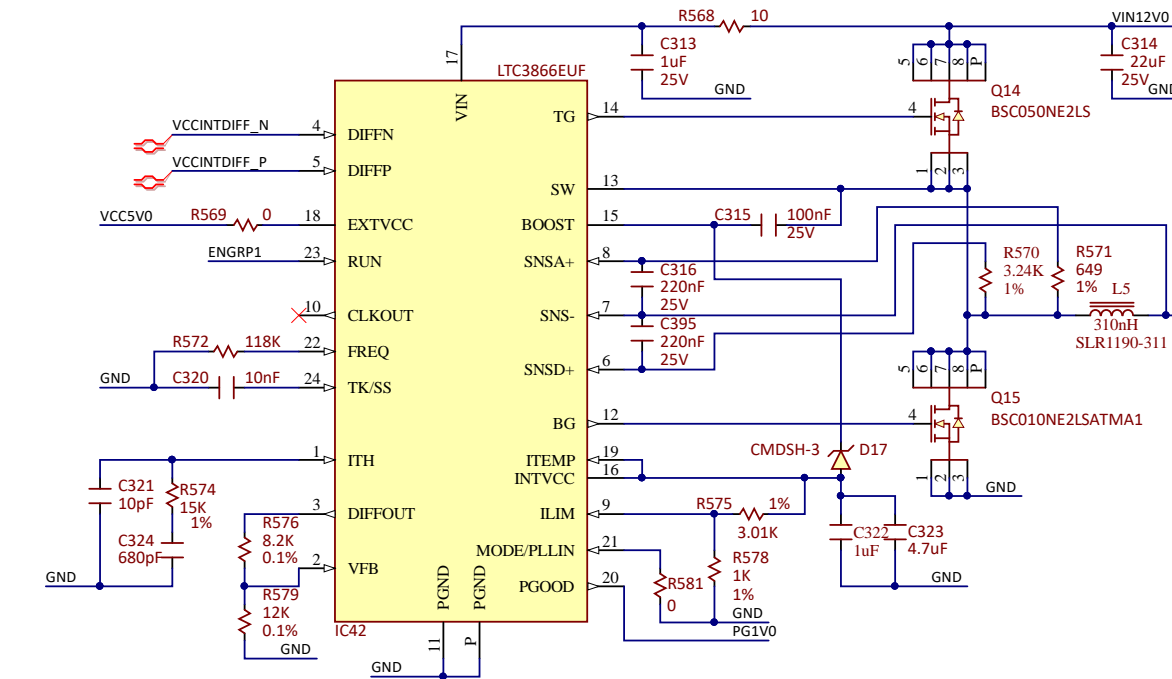

Title		Rev
<b>SWORD</b>		<b>C.1</b>
Circuit		Copyright 2018
POWER		
Doc#	500-354	
Engineer	MTA	
Author	GMA	
Date	1/17/2018	
Sheet#	24 out of 27	





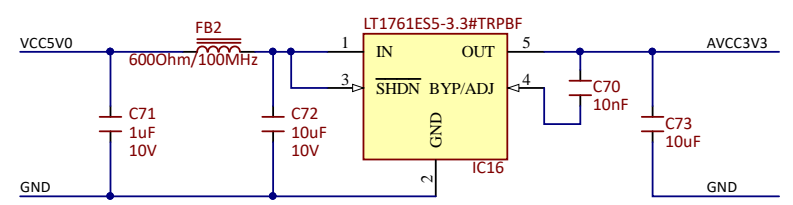
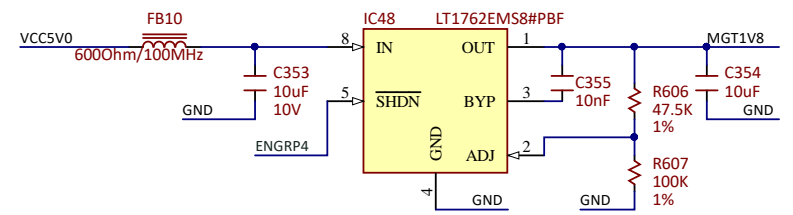
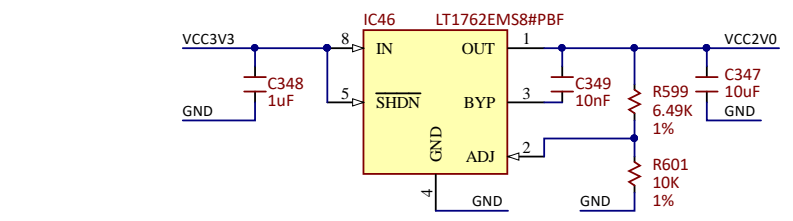
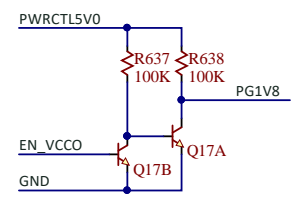
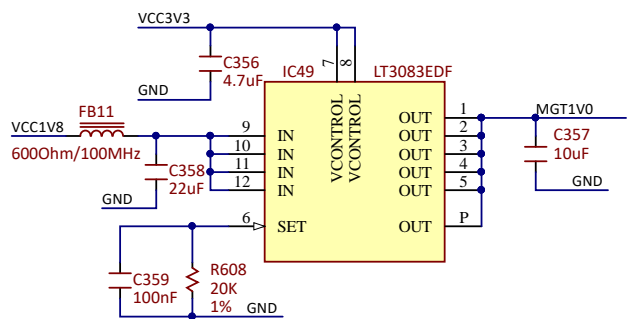
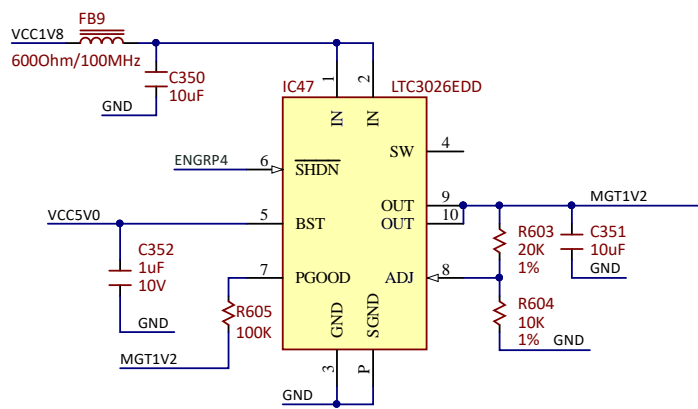
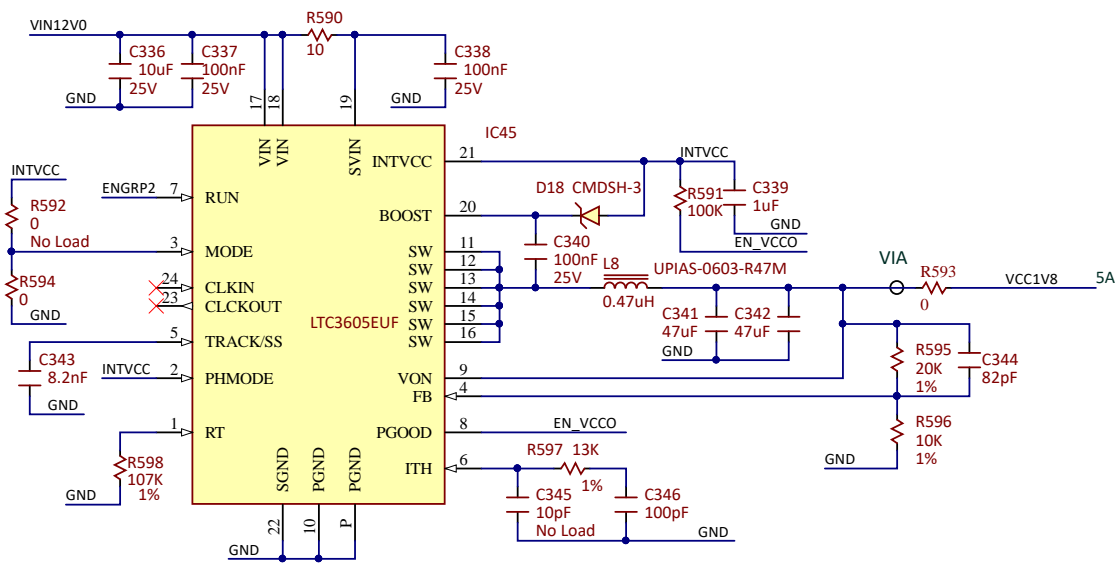

Title		Rev
<b>SWORD</b>		<b>C.1</b>
Circuit		Copyright 2018
POWER		
Doc#	500-354	
Engineer	MTA	
Author	GMA	
Date	1/17/2018	
Sheet#	25 out of 27	



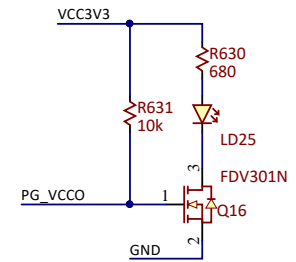
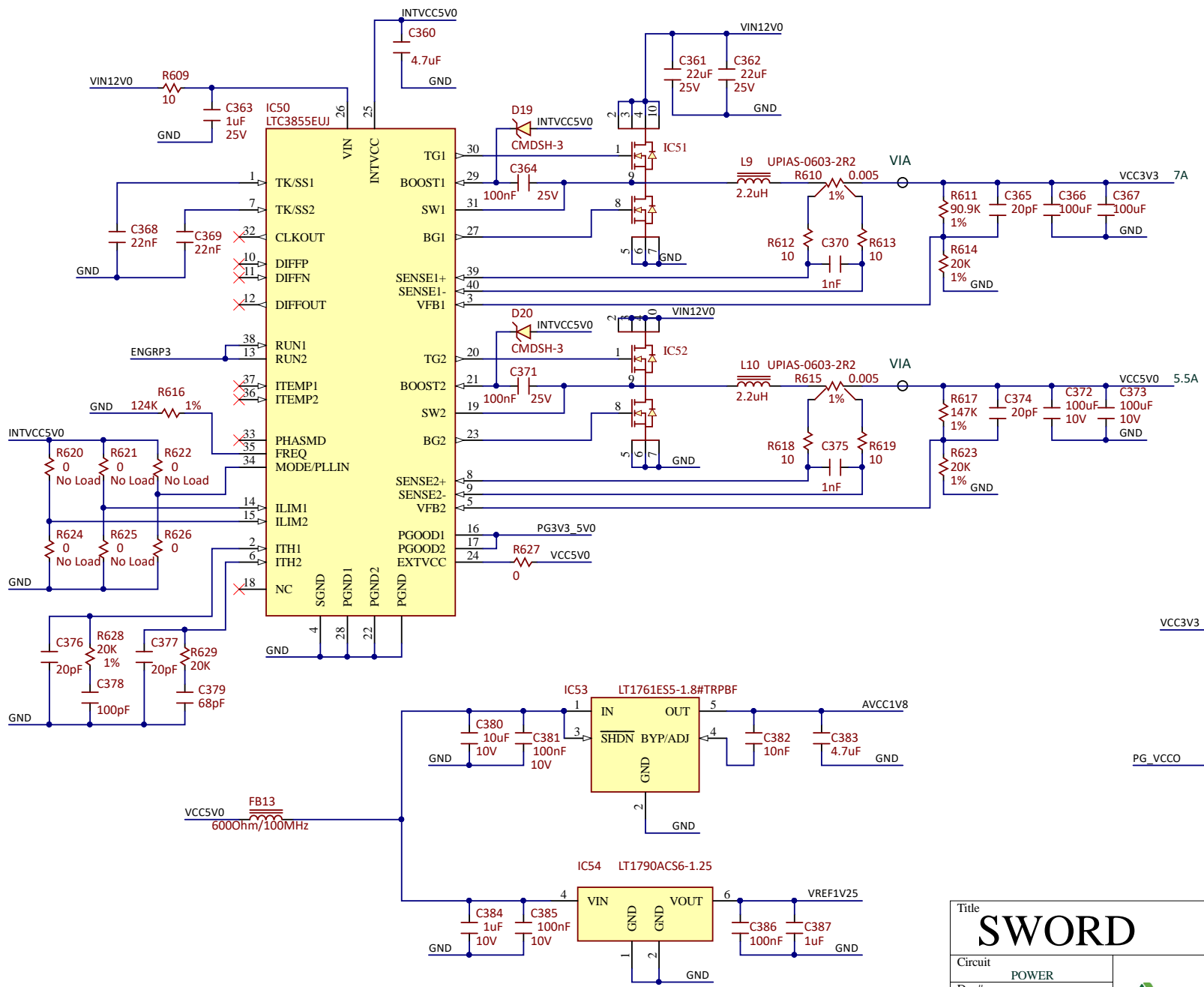

Title		Rev
<b>SWORD</b>		<b>C.1</b>
Circuit		Copyright 2018
Doc#	POWER	
Doc#	500-354	
Engineer	MTA	
Author	GMA	
Date	1/17/2018	
Sheet#	26 out of 27	



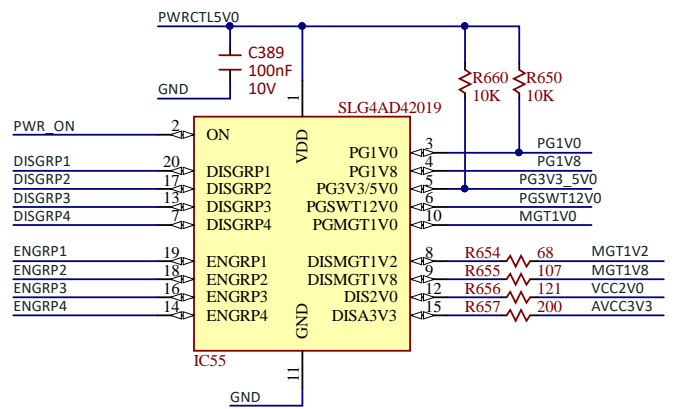
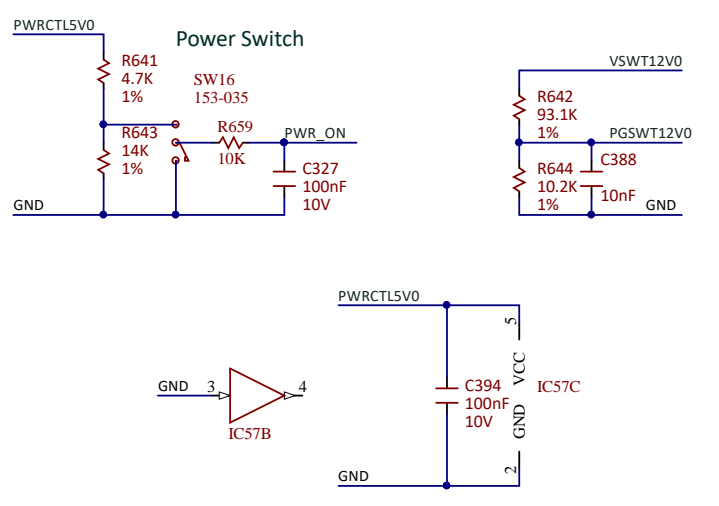
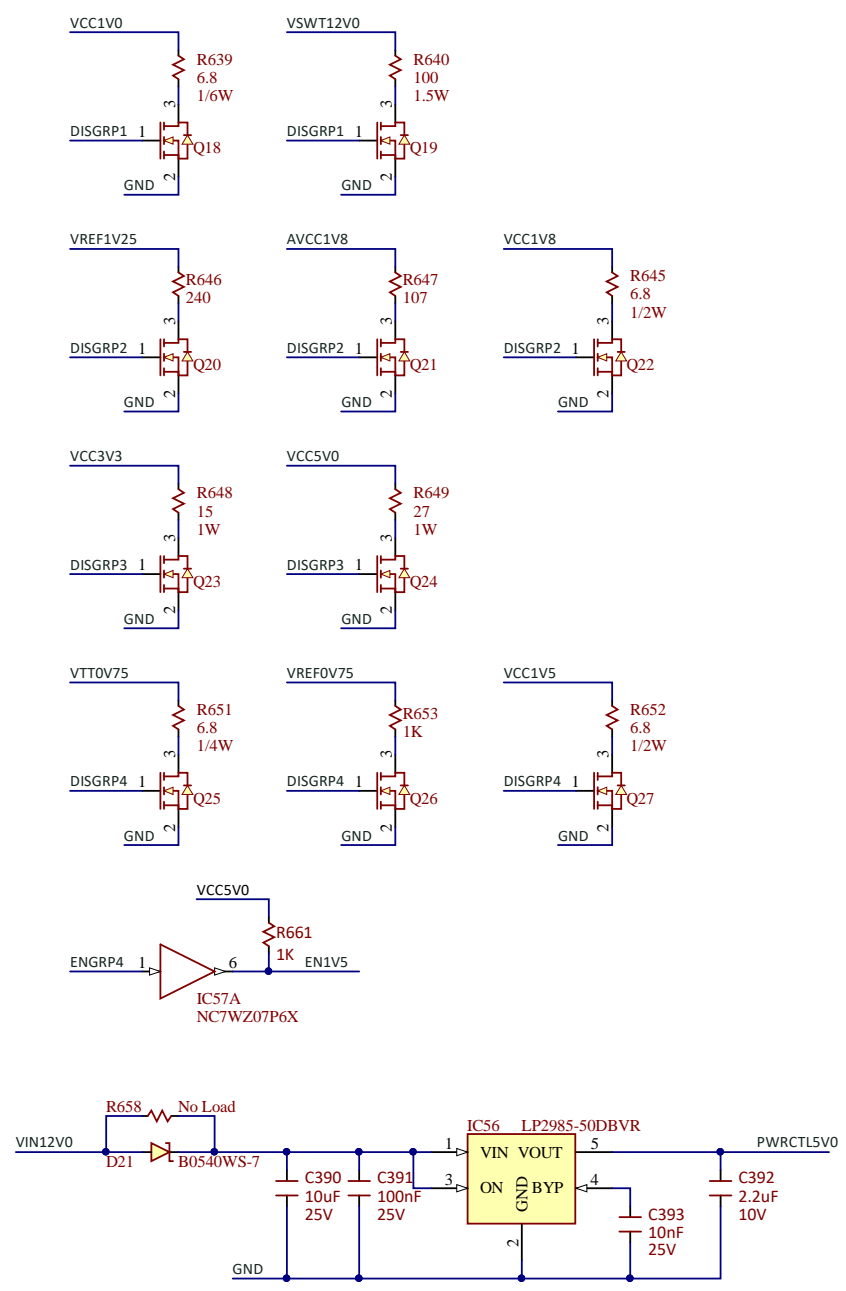

Title <b>SWORD</b>		Rev <b>C.1</b> Copyright 2018
Circuit Shutdown	Doc# 500-354	
Engineer MTA	Author GMA	
Date 1/17/2018	Sheet# 27 out of 27	