

Features

- Meets IEEE Standard 488.2-1992*
 - SH1, source handshake
 - AH1, acceptor handshake
 - T5 or TE5, talker or extended talker
 - L3 or LE3, listener or extended listener
 - SR1, service request
 - RL1, remote local
 - PP1 or PP2, parallel poll, remote or local configuration
 - DC1, device clear
 - DT1, device trigger
 - C₁-C₅, controller, all functions
- Programmable data transfer rate
- 16 registers, 8 read/8 write
- 2 address registers
 - Detection of MTA, MLA, MSA (my talk/my listen/my secondary addresses)
 - 2 device addresses
- EOS Message Automatic Detection
- Command (IEEE Standard 488-78) automatic processing and undefined command read capability
- DMA capability
- Programmable bus transceiver I/O specification (works with Texas Instruments/Motorola/Intel-compatible)
- 1 MHz to **20 MHz*** clock range
- Can monitor all bus control lines*
- Supports T1 delays of 2000, 500, **350 ns***
- +5V single power supply
- CMOS technology
- 8080/85/86 compatible
- Available in 40 Pin DIP and 44 Pin TQFP* packages
- Adds 488.2 features to NEC μPD7210 design*

*Items marked with an asterisk and shown in red are new features that are not supported by the NEC μPD7210.

The CB7210.2 is the new standard GPIB controller chip replacing the NEC μPD7210. Like many OEMs facing the eventual phasing out of the NMOS NEC μPD7210, Measurement Computing Corporation (MCC) needed a replacement, and needed it to embrace the latest technology, to preserve legacy code and circuitry, and to be available at a great price. So we designed one from the ground up.

Other vendors have introduced GPIB chips that are either outdated, such as the IOtech version which only supports 488.1 commands, or are restricted to Talker/Listener, such as the TNT488.2 chip from National Instruments. MCC's CB7210.2 is priced as low as \$8.00 in quantity, available in unrestricted Controller/Talker/Listener with all enhanced registers functioning, preserves legacy code in either package and preserves legacy circuitry in the 40-pin package.

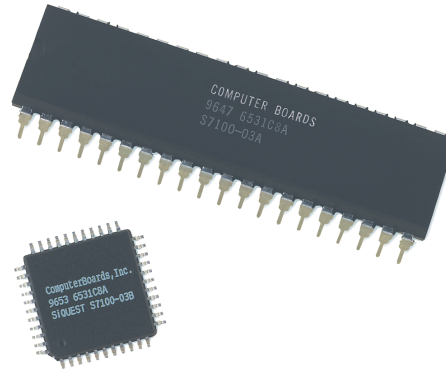

VHDL Source Available

The CB7210.2 is designed entirely in VHDL code and implemented as the state machines defined in the IEEE-488.2 specification, and the NEC μPD7210 data book. The CB7210.2 includes state machines which implement advanced functions found on the TNT488.2 GPIB controller from National Instruments. The VHDL code is available to manufacturers and OEM's designing systems and chips for GPIB instrumentation, control and analysis. Licenses are available for as little as fifty cents per instance of use.

High Speed State Machine Bus/FIFO Manager

An advanced state machine designed to handle bus transfers and a FIFO specifically for the CB7210.2 is available for the ISA, PCMCIA and PCI bus. You can integrate the ASIC equations into your own design.

Simply the Best GPIB Chip in the WORLD

The CB7210.2 is the best GPIB interface chip in the world. With an open design, unparalleled software support, advanced support circuitry, low cost and backed by Measurement Computing Corporation, the CB7210.2 is the new standard in GPIB components.

IEEE-488.2 (GPIB) Compatibility

The CB7210.2 adheres to ANSI/IEEE Standard 488-1978, and the update to the IEEE-488.2 specification. The IEEE-488 bus or GPIB (**General Purpose Interface Bus**) is a standard for instrumentation communication and control for instruments from manufacturers the world over.

Free Samples

Free samples of the CB7210.2 are available to OEMs or to anyone who owns any equipment with a socket for an NEC μPD7210 and wants to upgrade to the latest technology.

μPD7210 vs. CB7210.2

The CB7210.2 is a high performance extended version of the NEC μPD7210 GPIB controller chip. It is 100% software and hardware compatible with the NEC chip and can be used as a drop in replacement in existing designs. The CB7210.2 offers a number of significant enhancements. For new designs, the chip provides both higher performance and additional features.

Higher Performance

The maximum clock rate of the μPD7210 is 8 MHz. The CB7210.2 chip increases the maximum clock rate to 20 MHz. When running at identical clock rates, the CB7210.2 executes the GPIB handshaking protocol at faster rates, due to a more optimized design of the internal circuitry.

The CB7210.2 also supports a T1 delay of 350 ns (the minimum allowed by the IEEE 488 specification) in addition to the 500 ns and 2000 ns delays that are supported by the NEC μPD7210. These speed improvements allow straightforward hardware designs that can easily achieve the IEEE 488 specifications nominal maximum throughput of 1 MHz. With the CB7210.2 chip, the GPIB cable itself is the bottleneck. With a short cable, the CB7210.2 chip is capable of >1.5 MHz transfer speeds.

New Features

The CB7210.2 chip adds new features to the NEC μPD7210 that are implemented via new "hidden" registers added to the μPD7210 register map. These features are invisible when running existing μPD7210 software, but can be accessed by any software written for the CB7210.2 chip. The new features include:

- Ability to monitor the state of all bus control lines.
- Ability to monitor the internal state of all GPIB state machines.
- Improved SRQ handling as specified by IEEE 488.2. Includes Request For Service (RSV) state machine and support of local messages "reqt" and "reqf".
- Supports 350 ns T1 delay in addition to the 500 ns and 2000 ns T1 delays supported by the NEC μPD7210.

CMOS Technology

The original μPDP7210 was built in NMOS technology. This technology was state-of-the-art 20 years ago when the chip was released, but is outdated by today's standards. Today's CMOS is faster, consumes less power, and has equivalent drive capability with higher input impedances. These advantages, combined with the high circuit densities available, allow the new chip to offer higher performance and lower cost than the older μPDP7210.

Availability

The lack of a good chip source drove us to develop the CB7210.2. We are not like most big chip suppliers that let delivery on a chip stretch out to 12-16 weeks. In fact, we are our biggest customer. Without an adequate supply of chips, we can't ship our very successful GPIB board product line. You can be sure that we'll have the components when you need them. And since we have such a large investment in boards that use the chip, you can be sure that any chip upgrade or revision will not jeopardize 100% compatibility with previous versions. We don't want to *REV* our boards any more than you do!

Low Price

Those of you who know us from our highly successful board business know that Measurement Computing Corporation has built its business on providing quality products at extremely low prices. Look at the pricing of our board products and you'll see that we're serious about offering low prices. We're following this same low cost strategy on our chip products. Our goal is to never give you a reason to buy from anyone else. We offer premium quality products at rock bottom prices with quick delivery. Then we back the whole package up with exceptional service.

New Packaging

The μPD7210 is only available in a 40 pin DIP package, which is huge by today's standards. The CB7210.2 is available in a 44-pin, TQFP package that is small enough for use in PCMCIA cards, PC104 cards or in OEM applications where board real estate is at a premium. The TQFP package is also surface-mount compatible.

Bus/FIFO Manager Design Available

We've even done some of the board design work for you. While designing our own board level products, we developed an advanced state machine designed to handle bus transfers and a FIFO specifically for the CB7210.2. These designs are available for sale on the ISA, PCMCIA and PCI bus. Please call us at (508) 946-5100 for further details regarding our high-speed GPIB support designs.

Pin identification and Configuration

Pin #		Signal name*	I/O	Description
PDIP	TQFP			
1	40	T/R ₁	O	Transmit/Receive Control. Input/output control signal for the GPIB bus transceivers.
2	41	T/R ₂	O	Transmit/Receive Control. The values of T/R ₂ and T/R ₃ are determined by the values of the Address Mode register bits TRM1, and TRM0.
3	42	CLK	I	Clock. 1 MHz to 20 MHz reference clock for generating the state change prohibit times T ₁ , T ₆ , T ₇ , T ₉ specified in IEEE Standard 488.2-1992.
4	43	RESET	I	Reset. Resets the CB7210.2 to an idle state when high (active high).
5	44	T/R ₃	O	Transmit/Receive Control. See T/R ₂ .
6	1	DRQ	O	DMA Request. Requests data transfer. Becomes low on input of DMA acknowledge signal DACK.
7	2	DACK/	I	DMA Acknowledge. (Active Low) Signal connects the computer system data bus to the data register of the CB7210.2.
8	3	CS/	I	Chip Select. (Active Low) Enables access to the register selected by RS ₀ -RS ₂ (read or write operation).
9	4	RD/	I	Read. (Active Low) Places contents of read register specified RS ₀ -RS ₂ on D ₀ -D ₇ (computer bus).
10	5	WR/	I	Write. (Active Low) Writes data on D ₀ -D ₇ into the write register specified by RS ₀ -RS ₂ .
11	7	INT	O	Interrupt Request. (Active High/Low) Becomes active due to any 1 of 13 internal interrupt conditions (unmasked). Active state software configurable. Active high on chip reset.
12-19	8-15	D ₀ -D ₇	I/O	Data Bus. 8-bit bidirectional data bus for interface to the computer system.
20	6, 17, 28, 39	GND		Ground
21-23	18-20	RS ₀ -RS ₂	I	Register Select. These lines select one of eight read (write) registers during a read (write) operation.
24	21	IFC/	I/O	Interface Clear. Control line used for clearing the interface functions.
25	22	REN/	I/O	Remote Enable. Control line used to enable remote operation of the devices.
26	23	ATN/	I/O	Attention. Control line which indicates whether data on DIO lines is an interface message or device dependent message.
27	24	SRQ/	I/O	Service Request. Control line used to request service from the controller.
28-35	25-33	DIO ₁ /- DIO ₈ /	I/O	Data Input/Output. 8-bit bi-directional bus for transfer of message.
36	34	DAV/	I/O	Data Valid. Handshake line indicating that data on DIO lines is valid.
37	35	NRFDD/	I/O	Ready for Data. Handshake line indicating that device is ready for data.
38	36	NDAC/	I/O	Data Accepted. Handshake line indicating completion of message reception.
39	37	EOI/	I/O	End or Identity. Control line used to indicate the end of multiple byte transfer sequence or to execute a parallel polling in conjunction with ATN.
40	16, 38	V _{CC}	I/O	+5 VDC

* A "/" suffix following the signal name indicates that the signal is active low.

CB7210.2 – PDIP

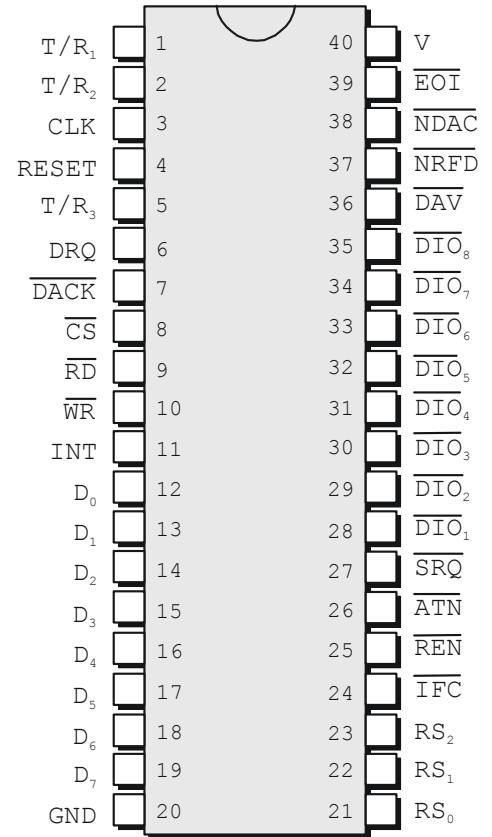

CB7210.2 – TQFP

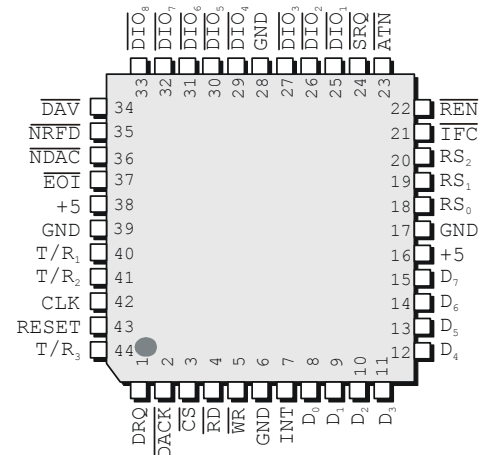

Block Diagram

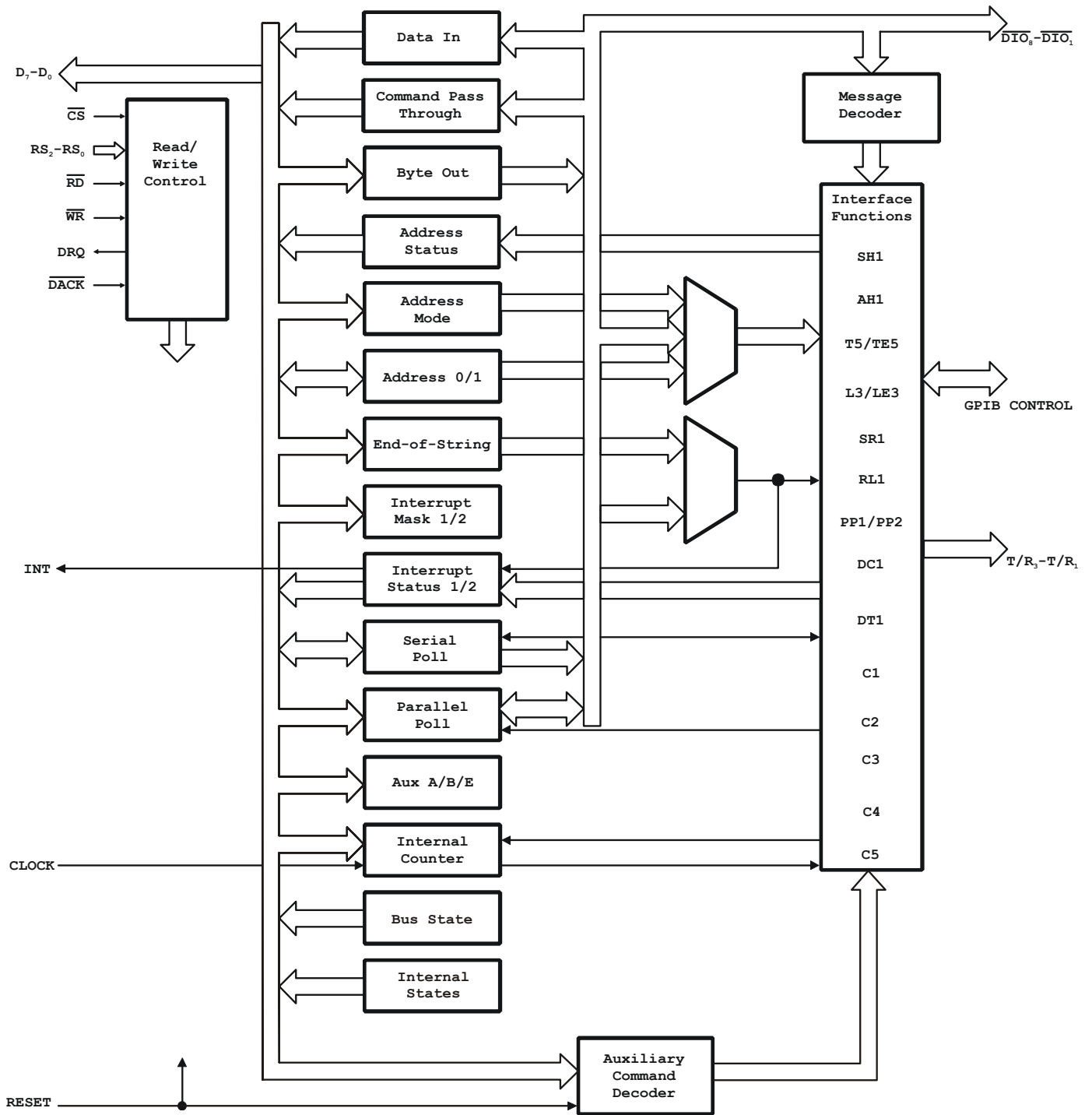

Electrical characteristics

Absolute Maximum Ratings

T(ambient) = 25 °C		
Parameter	Symbol	Test Conditions
Supply Voltage	V _{cc}	3 V to 7 V
Input Voltage	V _i	-0.3 V to V _{cc} + 0.3 V
Output Voltage	V _o	-0.3 V to V _{cc} + 0.3 V
Operating Temperature	T _{opr}	-55 °C to 125 °C
Storage Temperature	T _{stg}	-65 °C to 150 °C

Exposing the device to stresses above those listed in the Absolute Maximum Ratings table can permanently damage the CB7210.2. The device is not meant to be operated outside of the specified conditions. Exposure to absolute maximum rating conditions for extended periods may affect device reliability.

Capacitance

T _A = 25°C; V _{cc} = GND = 0V				
Parameter	Symbol	Max	Unit	Test Conditions
Input Capacitance	C _{in}	4	pF	F = 1 MHz
Output Capacitance	C _{out}	8	pF	
I/O Capacitance	C _{i/o}	8	pF	

DC characteristics

T _A = 0°C to 70°C; V _{cc} = 5V ± 10%					
Parameter	Symbol	Limits		Unit	Test Conditions
		Min	Max		
Input Low Voltage	V _{IL}	-0.3	0.8	V	
Input High Voltage	V _{IH}	2.0 V	V _{cc} + 0.3	V	
Low-Level Output Voltage	V _{OL}		0.4 V	V	I _{OL} = 6 mA V _{CC} = V _{cc} min
High Level Output Voltage	V _{OH}	2.4 V		V	I _{OH} = 6 mA V _{CC} = V _{cc} min
Input Leakage Current	I _L	-10	+10	µA	V _{cc} = V _{max}
Output Leakage Current	I _{OL}	-10	+10	µA	V _{cc} = V _{max}
Pull-up Resistor		50 K	500 K	ohms	V _{cc} = V _{max}
Supply Current	I _{cc}		30	mA	All outputs floating

Registers

Internal registers

The CB7210.2 has 16 registers: 8 read and 8 write. The register names marked with an * and shown in gray table cells are not compatible with the NEC μ PD7210.

Register Name	Addressing						Specifications							
	RS ₂	RS ₁	RS ₀	WR/	RD/	CS/								
Data In [OR]	0	0	0	1	0	0	D17	D16	D15	D14	D13	D12	D11	D10
Interrupt Status 1 [1R]	0	0	1	1	0	0	CPT	APT	DET	END	DEC	ERR	D0	D1
Interrupt Status 2 [2R]	0	1	0	1	0	0	INT	SRQI	LOK	REM	CO	LOKC	REMC	ADSC
*Serial Poll Status [3R]	0	1	1	1	0	0	S8	PEND	S6	S5	S4	S3	S2	S1
*Revision [3R]	0	1	1	1	0	0	0	0	0	1	0	0	0	0
*Address Status [4R]	1	0	0	1	0	0	CIC	ATN	SPMS	LPAS	TPAS	LA	TA	MJMN
*State 1 [4R]	1	0	0	1	0	0	T1	T0	AH2	AH1	AH0	SH2	SH1	SH0
*State 2 [4R]	1	0	0	1	0	0	DC	SR1	SR0	LE	L1	L0	SP	TE
*State 3 [4R]	1	0	0	1	0	0	C4-1	C4-0	DT	PE	PP1	PP0	RL1	RL0
*State 4 [4R]	1	0	0	1	0	0	C3-1	C3-0	C2-0	C1-0	C3	C2	C1	C0
Command Pass Through [5R]	1	0	1	1	0	0	CPT7	CPT6	CPT5	CPT4	CPT3	CPT2	CPT1	CPT0
Address 0 [6R]	1	1	0	1	0	0	X	DT0	DL0	AD5-0	AD4-0	AD3-0	AD2-0	AD1-0
*Address 1 [7R]	1	1	1	1	0	0	EOI	DT1	DL1	AD5-1	AD4-1	AD3-1	AD2-1	AD1-1
*Bus Status [7R]	1	1	1	1	0	0	NDAC	NRFD	DAV	REN	IFC	SRQ	EOI	ATN
Byte Out[0W]	0	0	0	0	1	0	BO7	BO6	BO5	BO4	BO3	BO2	BO1	BO0
Interrupt Mask 1 [1W]	0	0	1	0	1	0	CPT	APT	DET	END	DEC	ERR	DO	DI
Interrupt Mask 2 [2W]	0	1	0	0	1	0	0	SRQI	DMAO	DMAI	CO	LOKC	REMC	ADSC
Serial Poll Mode [3W]	0	1	1	0	1	0	S8	rsv	S6	S5	S4	S3	S2	S1
Address Mode [4W]	1	0	0	0	1	0	ton	lon	TRM1	TRM0	0	0	ADM1	ADM0
Auxiliary Mode [5W]	1	0	1	0	1	0	CNT2	CNT1	CNT0	COM4	COM3	COM2	COM1	COM0
Address 0/1 [6W]	1	1	0	0	1	0	ARS	DT	DL	AD5	AD4	AD3	AD2	AD1
End of String [7W]	1	1	1	0	1	0	EC7	EC6	EC5	EC4	EC3	EC2	EC1	EC0

Registers

Data Registers

Data registers are used for data and command transfers between the GPIB and the computer. The Data In register holds data sent from the GPIB to the computer. The Byte Out register holds information written into it for transfer to the GPIB.

Data In [0R]							
D17	D16	D15	D14	D13	D12	D11	D10
Byte Out [0W]							
BO7	BO6	BO5	BO4	BO3	BO2	BO1	BO0

Interrupt Registers

The Interrupt registers contain interrupt status bits, interrupt mask bits, and other non-interrupt bits.

Read

Interrupt Status 1 [1R]							
CPT	APT	DET	END	DEC	ERR	DO	DI
Interrupt Status 2 [2R]							
INT	SRQI	LOK	REM	CO	LOKC	REMC	ADSC

Write

Interrupt Mask 1 [1W]							
CPT	APT	DET	END	DEC	ERR	DO	DI
Interrupt Mask 2 [2W]							
0	SRQI	DMAO	DMAI	CO	LOKC	REMC	ADSC

There are 13 factors which can generate an interrupt from the CB7210.2, each with its own status and mask bit. Interrupt status bits are always set to 1 if the interrupt condition is met. The interrupt mask bits decide whether or not the INT bit and the interrupt pin will be active for that condition.

Interrupt status bits

- INT OR of All Unmasked Interrupt Status Bits
- CPT Command Pass Through
- APT Address Pass Through
- DET Device Trigger
- END End (END or EOS Message Received)
- DEC Device Clear
- ERR Error
- DO Data Out
- DI Data In
- SRQI Service Request Input
- LOKC Lockout Change
- REMC Remote Change
- ADSC Address Status Change
- CO Command Output

Non-interrupt related bits

- LOK Lockout
- REM Remote/Local
- DMAO Enable/Disable DMA Out
- DMAI Enable/Disable DMA In

Serial Poll Mode Registers

The Serial Poll Mode register holds the STB (status byte S8, S6-S1) sent over the GPIB and the local message rsv (request service). You can read the Serial Poll Mode register through the Serial Poll Status register. The PEND bit is set when $rsv = 1$. The PEND bit is cleared when $NPRS \cdot rsv/ = 1$, or the STB is read by the active controller. (NPRS = Negative Poll Response state)

Read

Serial Poll Status [3R]							
S8	PEND	S6	S5	S4	S3	S2	S1

Write

Serial Poll Status [3W]							
S8	rsv	S6	S5	S4	S3	S2	S1

Revision Register*

The Revision register contains a revision number for the CB7210.2. To access this register, write a Set Register Page command to the Auxiliary Mode register.

Revision [3R]							
0	0	0	0	0	0	0	0

Address Status/Address Mode Registers

The Address Mode register selects the address mode of the device, and also sets the mode for the transceiver control lines, T/R_3 and T/R_2 .

Address Status [4R]							
CIC	ATN	SPMS	LPAS	TPAS	LA	TA	MJMN
Address Mode [4W]							
ton	lon	TRM1	TRM0	0	0	ADM1	ADM0

The TRM1 and TRM0 values of the Address Mode register determine the functions of the T/R_2 and T/R_3 pins.

T/R_2	T/R_3	TRM 1	TRM 0
EOIOE	TRIG	0	0
CIC	TRIG	0	1
CIC	EOIOE	1	0
CIC	PE	1	1

EOIOE = TACS + SPAS + CIC · CSBS/

EOI/ pin output enable.

1: output

0: input

CIC = CIDS/ + CADS/

Controller in charge

1: ATN = output, SRQ = input

0: ATN = input, SRQ = output

PE = CIC + PPAS/

Pull-up enable for $DIO_8 - DIO_1$ and DAV lines.

1: Three-state

0: Open-collector

Registers

TRIG

TRIG pulses high when the Device Trigger Active State (DTAS) is initiated, or when a trigger auxiliary command is issued. Upon reset, TRM₀ and TRM₁ become 0 (TRM₀ = TRM₁ = 0) so that T/R₂ and T/R₃ both become low.

Address Status Bits

ATN	Data Transfer Cycle (Device in CSBS)
LPAS	Listener Primary Addressed state
TPAS	Talker Primary Addressed state
CIC	Controller Active
LA	Listener Addressed
TA	Talker Addressed
MJMN	Set = Minor T/L Address, Reset = Major T/L Address
SPMS	Serial Poll Mode state

Address Modes

ton	Ion	ADM1	ADM0	Address Mode	Contents of Address 0 Register	Contents of Address 1 Register
1	0	0	0	Talk only mode	Address identification not necessary (no controller on the GPIB) Not used	
0	1	0	0	Listen only mode		
0	0	0	1	Address mode 1 ¹	Major talk address or major listen address	Minor talk address or minor listen address
0	0	1	0	Address mode 2 ²	Primary address (talk or listen)	Secondary address (talk or listen)
0	0	1	1	Address mode 3 ³	Primary address (major talk or major listen)	Primary address (minor talk or minor listen)

Notes: Any combination other than those indicated is prohibited.

¹ Either MTA or MLA reception is indicated by coincidence of either address with the received address, interface function T or L

² Address register 0=primary; address register 1=secondary; interface function TE or LE.

³ CPU must read the secondary address via the Command Pass Through register interface function (TE or LE).

Address Registers

The CB7210.2 automatically detects two types of addresses which are held in Address registers 0 and 1.

Address 0 [6R]							
X	DT0	DL0	AD5-0	AD4-0	AD3-0	AD2-0	AD1-0
Address 1 [7R]							
EOI	DT1	DL1	AD5-1	AD4-1	AD3-1	AD2-1	AD1-1
Address 0/1 [6W]							
ARS	DT	DL	AD ₅	AD ₄	AD ₃	AD ₂	AD ₁

To set the address, write into the Address 0/1 register.

Address 0/1 Register Bit Selections

ARS	Selects either address register 0 or 1
DT	Permits or prohibits the address to be detected as Talk
DL	Permits or prohibits the address to be detected as Listen
AD ₅ -AD ₁	Device address value
EOI	Holds the value of EOI line when data is received

State Registers*

State registers show the internal states of all state machines. The states are as described in the IEEE-488 specification. To access the State registers, write a Set Register Page command to the Auxiliary Command register.

State 1	T1	T0	H2	AH1	AH0	SH2	SH1	SH0
State 2	DC	R1	SR0	LE	L1	L0	SP	TE
State 3	C4-1	C4-0	DT	PE	PP1	PP0	RL1	RL0
State 4	C3-1	C3-0	C2-0	C1-0	C ₃	C ₂	C ₁	C ₀

Command Pass Through Register

The Command Pass Through (CPT) register is used such that the CPU may read the DIO lines in the cases of undefined command, secondary address or parallel poll response.

Command Pass Through [5R]							
CPT7	CPT6	CPT5	CPT4	CPT3	CPT2	CPT1	CPT0

End-of-String Register

The End-of-String (EOS) register holds either a 7- or 8-bit EOS message byte used in the GPIB system to detect the end of a data block. The length of the EOS byte is selected by the A₄ function bit of Auxiliary Register A. The Auxiliary Register A function bits A₂ and A₃ control how the EOS register is used.

End of String [7W]							
EC7	EC6	EC5	EC4	EC3	EC2	EC1	EC0

Registers

Auxiliary Mode Register

The Auxiliary Mode register is a multipurpose register. A write to this register generates one of the following operations according to the values of the CNT bits.

Auxiliary Mode [5W]							
CNT2	CNT1	CNT0	COM4	COM3	COM2	COM1	COM0

CNT			COM					Function
2	1	0	4	3	2	1	0	
0	0	0	C ₄	C ₃	C ₃	C ₂	C ₀	Issues an auxiliary command specified by C ₄ to C ₀
0	0	1	0	F ₃	F ₂	F ₁	F ₀	The reference clock frequency (internal counter) determines T ₁ , T ₆ , T ₇ , and T ₉
0	1	1	U	S	P ₃	P ₂	P ₁	Sets the parallel poll register
1	0	0	A ₄	A ₃	A ₂	A ₁	A ₀	Sets the Auxiliary A register
1	0	1	B ₄	B ₃	B ₂	B ₁	B ₀	Sets the Auxiliary B register
1	1	0	0	0	0	E ₁	E ₀	Sets the Auxiliary E register
0	1	0	1	P ₃	P ₂	P ₁	P ₀	Sets the Register Page
0	1	0	0	X	X	X	U	Ultra-fast T ₁ Delay (350 ns)

Auxiliary Commands

0	0	0	C ₄	C ₃	C ₂	C ₁	C ₀
---	---	---	----------------	----------------	----------------	----------------	----------------

Command					Aux	Command Function
C ₄	C ₃	C ₂	C ₁	C ₀		
0	0	0	0	0	iepon	Immediate Execute pon, Generate Local pon message
0	0	0	1	0	crst	Chip Reset (same as External Reset)
0	0	0	1	1	rrfd	Finish Handshake (release RFD)
0	0	1	0	0	trig	Trigger
0	X	1	0	1	rtl	Return to Local
0	0	1	1	0	seoi	Send EOI message
0	0	1	1	1	nvld	Non-valid (OSA Reception), Release DAC Holdoff
0	1	1	1	1	vld	Valid (MSA Reception, CPT, DEC, DET), Release DAC Holdoff
0	X	0	0	1	sppf	Set/Reset Parallel Poll Flag
1	0	0	0	0	gts	Go To Standby
1	0	0	0	1	tca	Take Control Asynchronously
1	0	0	1	0	tcs	Take Control Synchronously
1	1	0	1	0	tcse	Take Control Synchronously on End
1	0	0	1	1	ltn	Listen
1	1	0	0	0	reqt	Request RSV bit TRUE
1	1	0	0	1	reqf	Request RSV bit FALSE
1	1	0	1	1	ltnc	Listen with Continuous Mode
1	1	1	0	0	lun	Local Unlisten
1	1	1	0	1	epp	Execute Parallel Poll
1	X	1	1	0	sifc	Set/Reset IFC
1	X	1	1	1	sren	Set/Reset REN
1	0	1	0	0	dsc	Disable System Control

Internal Counter

The internal counter generates the state change prohibit times (T₁, T₆, T₇, T₉) specified in the IEEE Standard 488-1978 with reference to the clock frequency.

0	0	1	0	F ₃	F ₂	F ₁	F ₀
---	---	---	---	----------------	----------------	----------------	----------------

Auxiliary A Register

Bits A₀-A₁ control the GPIB data receiving modes of the CB7210.2. Bits A₂-A₄ control how the EOS message is used.

1	0	0	A ₄	A ₃	A ₂	A ₁	A ₀
---	---	---	----------------	----------------	----------------	----------------	----------------

A ₁	A ₀	Data Receiving Mode
0	0	Normal handshake mode
0	1	RFD Holdoff on all data modes
1	0	RFD Holdoff on end mode
1	1	Continuous mode

Bit Name	Value	Function
A ₂	0 Prohibit 1 Permit	Permits or prohibits the setting of the END bit by reception of the EOS message
A ₃	0 Prohibit 1 Permit	Permits or prohibits automatic transmission of END message simultaneously with the transmission of EOS message TACS
A ₄	0 7-bit EOS 1 8-bit EOS	Makes the 7-bit or 8-bit contained in the EOS register the valid EOS message.

Auxiliary B Register

The Auxiliary B register function is similar to the Auxiliary A register function. This register controls the special operating features of the device.

1	0	1	B ₄	B ₃	B ₂	B ₁	B ₀
---	---	---	----------------	----------------	----------------	----------------	----------------

Bit Name	Value	Function
B ₀	1 Permit 0 Prohibit	Permits (prohibits) the setting of the CPT bit on receipt of an undefined command
B ₁	1 Permit 0 Prohibit	Permits (prohibits) the transmission of the END message when in serial poll active state
B ₂	1 T ₁ (high-speed)	T ₁ in source handshake function after transmission of second byte following data transmission
	0 T ₁ (low speed)	Sets T ₁ for all cases
B ₃	1 INT 0 INT/	Specifies the active level of the INT pin
B ₄	1 <i>ist</i> = SRQS	SRQS indicates the value of the <i>ist</i> level local message (the value of the parallel poll flag is ignored) SRQS = 1... <i>ist</i> = 1 SRQS = 0... <i>ist</i> = 0
	0 <i>ist</i> = Parallel Poll Flag	The value of the parallel poll flag is taken as the <i>ist</i> local message

Registers

Auxiliary E Register

The Auxiliary E register function controls the Data Acceptance modes of the CB7210.2.

1	1	0	0	0	0	E ₁	E ₀
---	---	---	---	---	---	----------------	----------------

Bit Name	Value	Function
E ₀	1 Enable 0 Disable	DAC Holdoff by Initiation of DCAS
E ₁	1 Enable 0 Disable	DAC Holdoff by Initiation of DTAS

Parallel Poll Register

The Parallel Poll register function defines the parallel poll response of the CB7210.2.

0	1	1	U	S	P ₃	P ₂	P ₁
---	---	---	---	---	----------------	----------------	----------------

U	1 = No parallel poll response 0 = Parallel poll response
S	Specify the status bit polarity 1 = In Phase 0 = Reverse Phase
P ₃ P ₂ P ₁	Specify status bit output line (DIO ₁ -DIO ₈)

Bus State Register*

The Bus State register indicates the current state of all bus control lines. To access the Bus State register, write a Set Page Register command to the Auxiliary Command register.

Bus State [7R]							
NDAC	NRFD	DAV	REN	IFC	SRQ	EOI	ATN

AC Characteristics

In the following table, 1 clock cycle = 50 ns.

T _A = 0C to 70C; V _{CC} = 5V ± 10%								
Parameter	Symbol	Limits						Test Conditions
		Min clock limit (clock + ns = min clock)			Max clock limit (clock + ns = max clock)			
		clock cycle	ns	Min clock	clock cycle	ns	Max clock	
EOI ↓ → DIO	t _{EODI}				-	30	30 ns	PPSS → PPAS, ATN = True
EOI ↓ → T/R1 ↑	t _{EOT11}				-	20	20 ns	PPSS → PPAS, ATN = True
EOI ↑ → T/R1 ↓	t _{EOT12}				-	25	25 ns	PPAS → PPSS, ATN = False
ATN ↓ → NDAC ↓	t _{ATND}				1	20	70 ns	AIDS → ANRS, LIDS
ATN ↓ → T/R1 ↓	t _{ATT1}				-	30	30 ns	TACS + SPAS → TADS, CIDS
ATN ↓ → T/R2 ↓	t _{ATT2}				-	30	30 ns	TACS + SPAS → TADS, CIDS
DAV ↓ → DRQ	t _{DVRQ}				1	30	80 ns	ACRS → ACDS, LACS
DAV ↓ → NRFD ↓	t _{DVNR1}				-	10	10 ns	ACRS → ACDS
DAV ↓ → NDAC ↑	t _{DVND1}				-	45	45 ns	ACRS → ACDS → AWNS
DAV ↑ → NDAC ↓	t _{DVND2}				1 ½	20	95 ns	AWNS → ANRS
DAV ↑ → NRFD ↑	t _{DVNR2}				-	10	10 ns	AWNS → ANRS → ACRS
RD ↓ → NRFD ↑	t _{RNR}				1 ½	10	85 ns	ANRS → ACRS LACS, DI register selected
NDAC ↑ → DRQ ↑	t _{NDRQ}				2 ½	20	145 ns	STRS → SWNS → SGNS, TACS
NDAC ↑ → DAV ↑	t _{NDDV}				1	25	75 ns	STRS → SWNS → SGNS
Address Setup to RD	t _{AR}	-	20	20 ns				RS ₀ to RS ₂ CS
Address Hold from RD	t _{RA}	-	0	0 ns				
RD Pulse Width	t _{RR}				-	0	0 ns	
Data Delay from RD ↓	t _{RD}				-	15	15 ns	
Output Float Delay from RD ↑	t _{DF}				-	20	20 ns	
RD Recovery Time	t _{RV}	1	0	50 ns				
Address Setup to WR	t _{AW}	-	0	0 ns				
Address Hold from WR	t _{WA}	-	0	0 ns				
WR Pulse Width	t _{WW}	1	0	50 ns				
Data Setup to WR	t _{DW}	-	20	20 ns				
Data Hold from WR	t _{WD}	-	0	0 ns				
WR Recovery Time	t _{RV}	1	0	50 ns				
DRQ ↓ Delay from DACK	t _{AKRQ}				-	10	10 ns	
Data Delay from DACK	t _{AKD}				-	15	15 ns	
DACK hold time from WR ↑	t _{DH}	-	0	0 ns				

Timing Waveforms and CPU Interface

DMA Read Timing

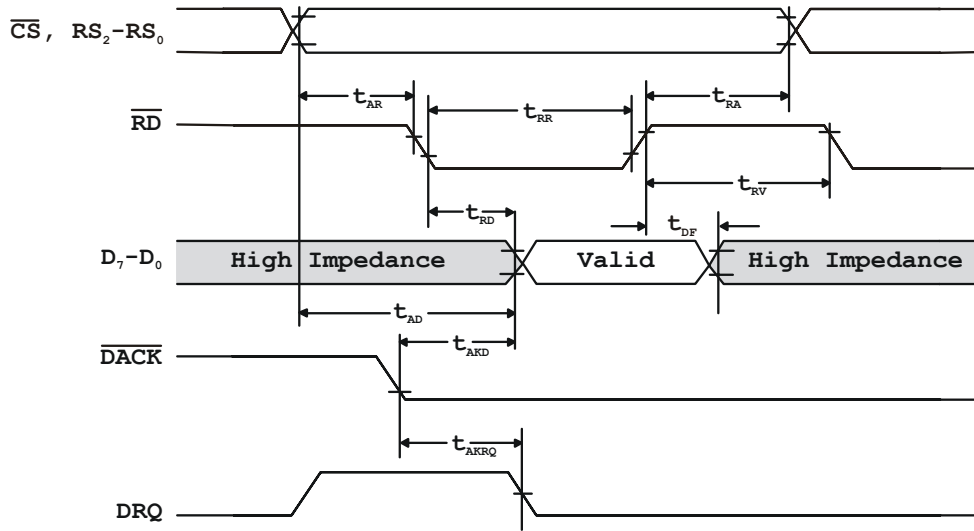

DMA Write Timing

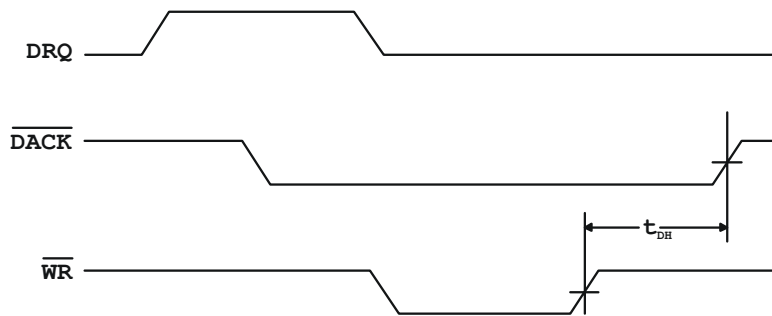

CPU Read/Write

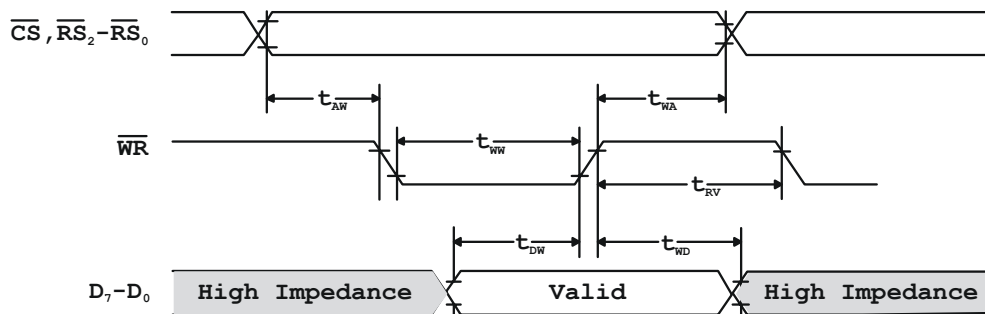

Timing Waveforms and CPU Interface

CPU Interface

You can easily interface the CB7210.2 to common microprocessor or microcomputer chips. A block diagram of the CB7210.2 to an 8085 interface is shown below.

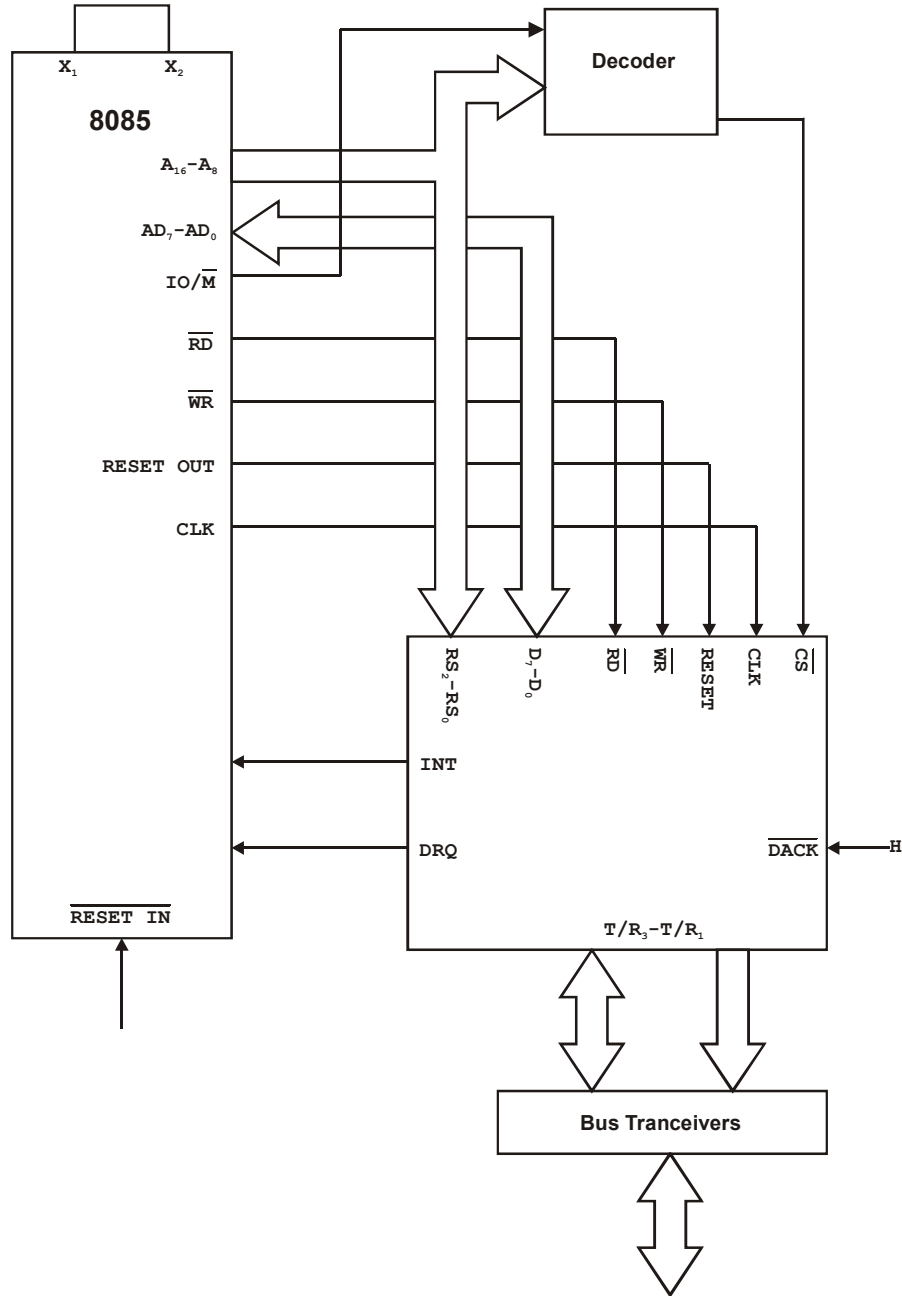

Contact us by phone or email if you need assistance in developing the interface to your particular system. Our engineering staff will work with you to ensure that your CB7210.2 interface is simple, efficient and allows access to all chip features.

- Phone: 508-946-5100 and follow the instructions for reaching Tech Support.
- Email: techsupport@measurementcomputing.com

Transceiver Examples

MC3448A-based transceiver

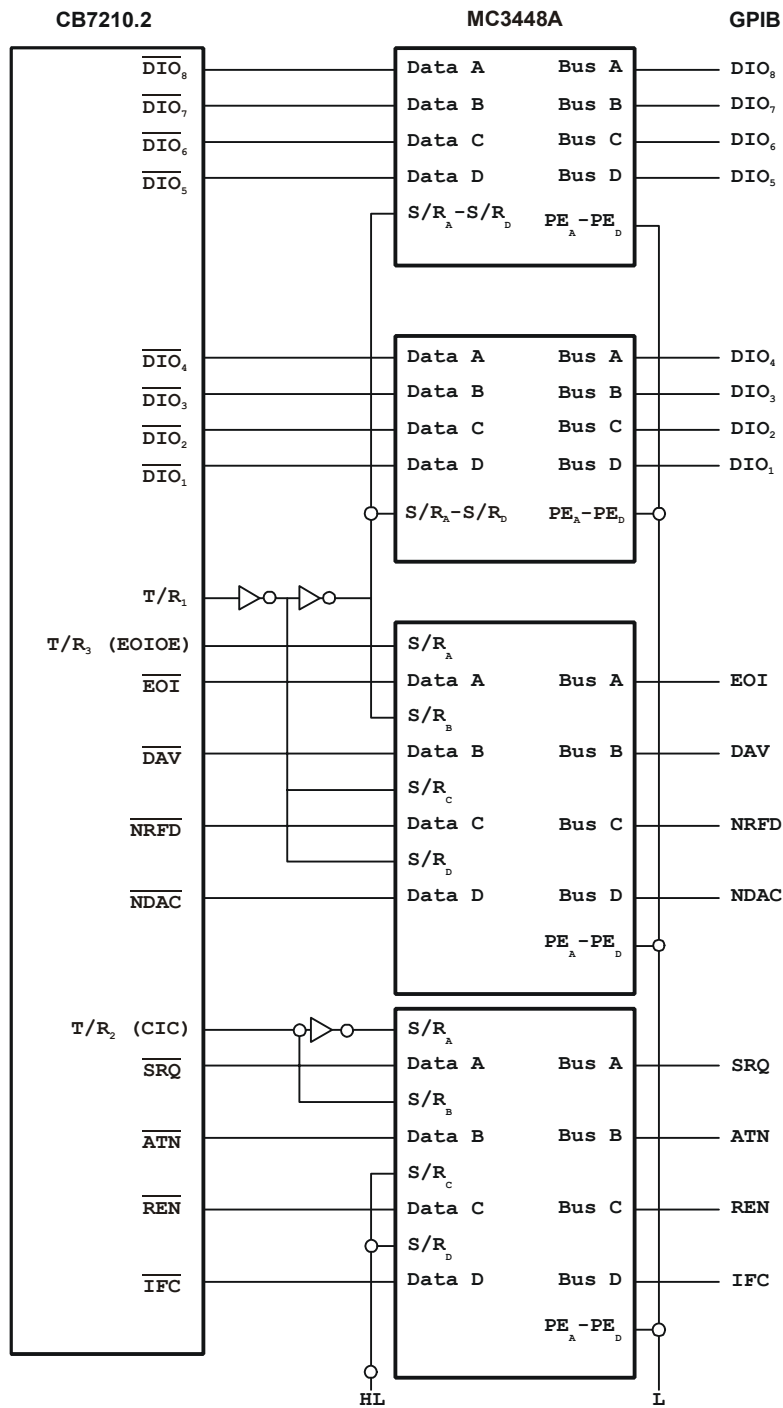

In this example, a high-speed transfer cannot be made, since the bus transceiver is an open collector type.

Transceiver Examples

SN75160-based transceiver

When configured for a low-speed data transfer (Auxiliary B Register bit B₂ = 0), you can use the TR₃ pin as a TRIG output. The PE input of SN75160 should be cleared to 0.

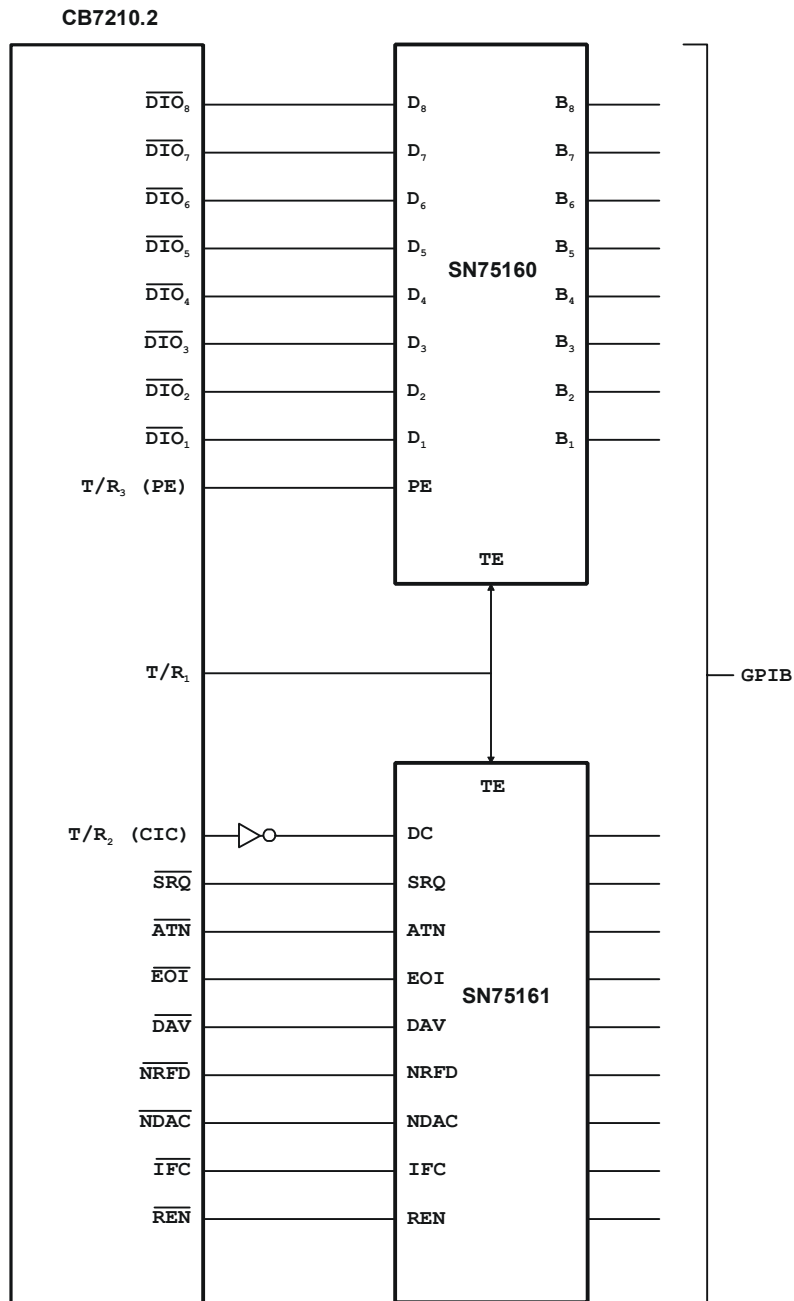

Package Outlines

CB7210.2-PDIP

Item	Millimeters
A	51.5 max
B	1.62 max
C	2.54 ± 0.1
D	0.5 ± 0.1
E	48.26 ± 0.1
F	1.2 min
G	2.54 min
H	0.5 min
I	5.22 max
J	5.72 max
K	15.24 typ
L	13.2 typ
M	0.25 (+0.1, -0.05)

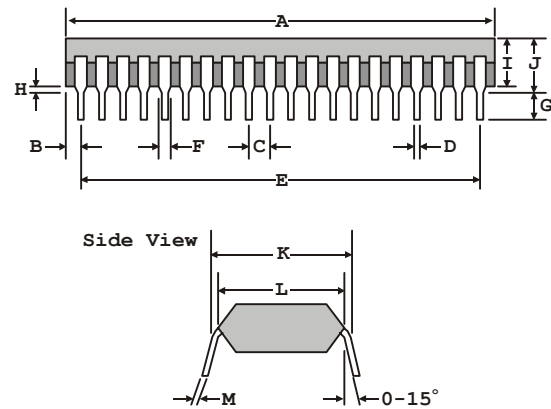

CB7210.2-TQFP

Item	Min.	Nom.	Max.
A	12.00 ± 0.2 BSC		
B	10.00 BSC		
C	12.00 ± 0.2 BSC		
D	10.00 BSC		
E	0.80 BSC		
F	0.30 mm	0.37 mm	0.45 mm
G	0.5 mm	0.10 mm	0.15 mm
H	0.09 mm	-	0.20 mm
I	0.9 mm	1.4 mm	1.9 mm
J	11°	12°	13°
K	0.45 mm	0.65 mm	0.75 mm
L	0°	-	7°
M	0.09R	-	0.20R

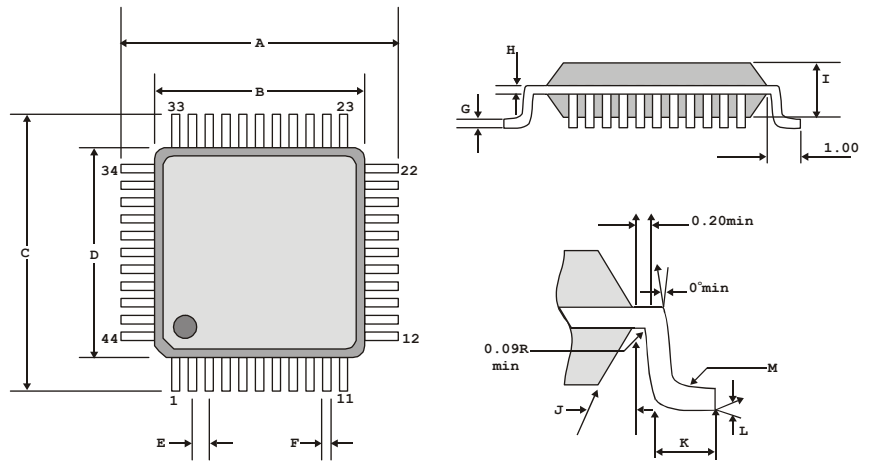

Measurement Computing Corporation
16 Commerce Boulevard,
Middleboro, Massachusetts 02346
(508) 946-5100
Fax: (508) 946-9500
E-mail: info@mccdaq.com
www.mccdaq.com