

### Features

- Eight channels of dynamic signal input for the WaveBook or ZonicBook
- Built-in IEPE biasing (4 mA), software selectable per channel
- AC or DC coupling, software selectable per channel
- Simultaneous sampling on all channels
- 8-pole Butterworth low-pass filter, programmable on a per-channel basis from 10 Hz to 50 kHz
- Programmable overrange detection
- IEPE fault detection
- TEDS support for accelerometers
- 25 VDC input range for proximity sensors
- AC excitation source
- 8 signal outputs for use as signal conditioning only
- Each input channel is provided as a conditional analog output on rear panel



The WBK18 provides a full set of features for making dynamic signal measurements

The WBK18 provides 8 channels of dynamic signal input for WaveBook or ZonicBook systems. The WBK18 provides all of the signal conditioning and biasing required for the system to accept piezoelectric accelerometers, piezoelectric pressure sensors, piezoelectric microphones, proximity sensors, or any other dynamic input source. All channels on the WBK18, and on other WBK18 modules within the same system, are sampled simultaneously to insure phase matching between channels. Each WBK18 channel features a software programmable 8-pole low-pass filter to remove undesired frequencies and alias components. Data integrity is additionally insured through overrange and IEPE fault detection mechanisms.

Each WBK18 channel has independent software control for AC or DC coupling, IEPE biasing (0 or 4 mA), programmable gain, and low-pass filter cutoff frequency. The WBK18 also includes a built-in programmable voltage excitation source for exciting other system elements such as shakers or speakers.

Up to 8 WBK18s can be attached to one WaveBook for a total IEPE sensor capacity of 64 channels (56 channels on ZonicBook). For applications where more than 64 channels are required, or where the per-channel bandwidth is higher than what a single WaveBook can support, up

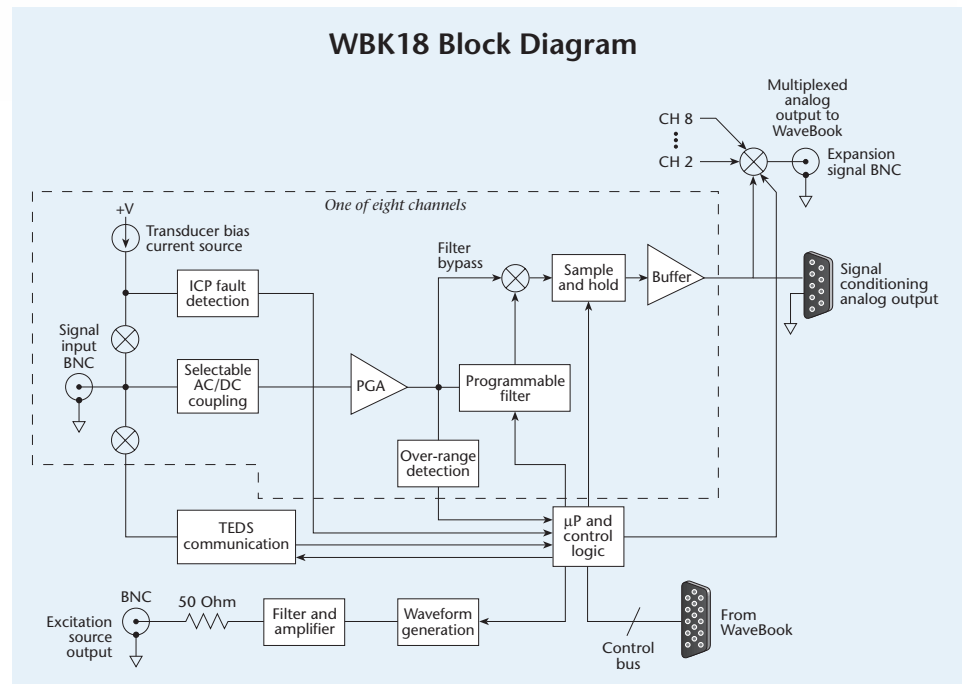

to four WaveBooks can be synchronized in one system for a total system capacity of 256 IEPE inputs.

**Programmable Coupling/Gain.** Each of the WBK18's eight inputs feature per channel software selection of AC/DC coupling and input gain range selection. A 0.1 Hz and 1 Hz high-pass cut-off selection is available in AC coupling mode with gain ranges from 25 mV to 5V full scale. In DC coupling mode an extra 25V range is available for proximity sensor measurements.

**Flexible Input.** When not using an IEPE transducer the current source can be individually disabled allowing connection of non-IEPE, high-output transducers or pre-conditioned signals from charge amplifiers.

**Low-Pass Filter.** For dynamic signal inputs each channel features an 8-pole Butterworth low-pass filter, programmable on a per channel basis from 10 Hz to 50 kHz in a 1-2-5 progression. This filter provides at least 75 dB of alias rejection to the WaveBook's A/D converter. For DC inputs such as

# WBK18

## Specifications & Ordering Information



proximity probes, LVDT's or other low frequency inputs where aliasing is less of a concern and the static DC value is more critical, a 2-pole filter is also available on each of the eight channels.

**Simultaneous Sample & Hold.** All WBK18 channels are sampled simultaneously, after which the WaveBook or ZonicBook measures each output until all channels are digitized\*. The time-skew between channels is 100 ns, regardless of the number of WBK18s connected to the WaveBook or ZonicBook. The WaveBook's eight built-in channels can also be sampled simultaneously if the WaveBook is equipped with a WBK11/HR or WBK13A simultaneous sample and hold option card.

**Overrange Detection.** Hardware overrange detection is built into the WBK18, with LEDs for each channel on the front panel for visual indication of an error condition. The overrange level is programmable as a percentage of range and is continuously monitored during an acquisition. Moreover, an error condition is latched until the commencement of a new acquisition. However, an overrange event does not stop the acquisition process or change the data, providing the user with full control over the disposition of data. In addition to front panel indicators, an overrange condition is also detectable by requesting status via software at the end of an acquisition.

**IEPE Fault Detection.** IEPE fault detection is also provided, with a front panel LED indicator for each channel. This hardware detection monitors for an open as well as a shorted transducer connection. Because it is continuously monitored during an acquisition, even intermittent faults are detected and latched. As with overrange detection, detection of this error condition does not alter the acquisition process or its data, and fault status is available via software at the end of an acquisition.

**TEDS Support.** TEDS, Transducer Electronic Data Sheet, is a sensor feature referring to the storage of calibration information within the sensor. The WBK18 can read calibration information from TEDS-compatible sensors and automatically scale the readings from each sensor using the acquired calibration information. TEDS support is a software option for the WBK18, and can be easily added after the initial purchase.

**Excitation Source.** The WBK18's AC excitation source is a sine wave-based voltage source that is programmable in frequency from 1 Hz to 5 kHz and in amplitude from 100 mVp-p to 10 Vp-p. Continuous sine, and Sweep sine modes are available. It can be used as a test source for the input channels or as excitation for other system elements, such as the amplifier for a shaker table. All of its parameters are software controlled, and its output is conveniently provided on a front panel BNC connection.

**Power.** The WBK18 can be powered by an included AC power adapter or directly from any 10 to 30 VDC source, such as a 12V car battery. For portable or field applications, the WBK18 and the WaveBook can be powered by the DBK30A rechargeable battery module.

### Included Software Support:

- WaveView *Out-of-the-Box* software
- DaqCOM ActiveX/COM support for Visual Studio® and Visual Studio®.NET
- DASyLab® drivers
- LabVIEW® VI examples
- eZ-Analyst support
- eZ-TOMAS support

## Specifications

### General

**Input Power Range:** 10 to 30 VDC

**Power Consumption**

@ 12V: 19.2W

@ 15V: 19.5W

@ 24V: 19.2W

### Environment

**Operating:** 0 to 50 °C; 0 to 95% RH, noncondensing

**Storage:** 0 to 70 °C

**Vibration:** MIL STD 810E, category 1

**Dimensions:** 280 mm W x 216 mm D x 45 mm H  
(11" x 8.5" x 1.75")

**Weight:** 1.3 kg (2.9 lbs)

### Analog Inputs

**Channels:** 8

**Signal Connection:** 1 BNC per channel

**Input Impedance:** 200k Ohm (single-ended)

**Input Coupling:** AC, DC (software programmable per channel)

**High-Pass Filter:** 0.1 Hz or 1 Hz (software programmable per channel)

**Input Ranges:** ±25V (DC coupled only), ±5V, ±2.5V, ±1V, ±500 mV, ±250 mV, ±100 mV, ±50 mV, ±25 mV (software programmable per channel)

**Overrange Detection:** Programmable from 1% to 100% of range

**Overrange Indication:** Front panel LED per channel, software status

**Low-Pass Filter** (software programmable per channel)

**Type:** 8-pole Butterworth with simultaneous sample-and-hold (SSH)

**Cutoff Frequency (Fc):** 10 Hz to 50 kHz in 1-2-5 progression

**Alias Rejection:** 75dB min

**Channel-to-Channel Phase Matching\*\*:** 1° typ, 2° max

**Unit-to-Unit Phase Matching\*\*:** 1° typ, 2° max

**SSH latency:** 100ns max

**Amplitude Accuracy†:** ±0.5dB (Fin ≤ Fc/2)

**Total Harmonic Distortion:** -70dB typ

**IEPE Bias Source:** 4 mA, 24V compliance (on/off software programmable per channel)

**IEPE Fault Detection Thresholds:** <1V (short), >25V (open)

**IEPE Fault Indication:** Front panel LED per channel, software status

### Excitation Source

**Channels:** 1

**Signal Connection:** BNC

**Frequency Range:** 1 Hz to 5 kHz

**Frequency Resolution:** 0.01 Hz

**Amplitude Settings (p-p):** 10V, 5V, 2V, 1V, 500 mV, 200 mV, 100 mV, 50 mV

**Waveform Modes:** Continuous sine, Sweep sine

**Output Impedance:** 50 Ohm

**Accuracy:** ±0.1dB

## Ordering Information

Description	Part No.
8-channel dynamic signal conditioning module for the WaveBook and ZonicBook	WBK18

### Product Compatibility

- ✓ WaveBook
- ✓ ZonicBook

\* When using a WaveBook system with a WBK11/HR, WBK13A, WBK16/SSH, or WBK18, the per channel sample rate is  $\frac{1 \text{ MHz}}{(n + 1)}$  where n=number of active channels

\*\* Conditions: 8-pole LPF mode, 0.1 Hz, 2 Hz, or DC HPF mode; 1 Hz ≤ Fin ≤ Fc/2; 200 Hz ≤ Fc ≤ 20 kHz; all WBK18 units connected to same WaveBook

† For Fin ≤ 20 kHz