

DT9847 Series

Dynamic Signal Analyzer for USB With Low THD and Wide Dynamic Range

Overview

The DT9847 Series are high-accuracy, dynamic signal acquisition modules designed for sound and vibration applications. These modules are ideal for precision measurements with microphones, accelerometers, and other transducers that have a large dynamic range. Common applications include audio, acoustic, and vibration testing.

Combine the DT9847 with the ready-to-measure QuickDAQ application to create a powerful FFT Analyzer instrument. Additionally, all Data Translation devices include comprehensive driver and software support, and interface tools for LabVIEW™ and MATLAB® programmers.

Key Features

- Simultaneous analog input and waveform analog output operations
- Analog input subsystem:
 - Up to three, simultaneous 24-bit A/D converters
 - Sample rate from 1 kS/s to 216 kS/s
 - Input range of ± 10 V with software-selectable gains of 1 and 10 for an effective input range of ± 10 V and ± 1 V
 - Support for Integrated Electronic Piezoelectric (IEPE) inputs, including use of a 4 mA current source with 18 V compliance voltage for AC or DC coupling
 - Supports a start trigger for acquiring pre-trigger samples and a reference trigger for acquiring post-trigger samples. Specify the number of post-trigger samples to acquire before stopping the operation.
 - For the start trigger, supports a software-programmable trigger source (software, external digital trigger, or a positive- or negative-going analog threshold trigger on any of the analog input channels). The threshold trigger can be programmed for a value from ± 10 V.
 - For the reference trigger, supports a positive- or negative-going analog threshold trigger on any of the analog input channels. The threshold trigger can be programmed for a value from ± 10 V.
- Analog output subsystem:

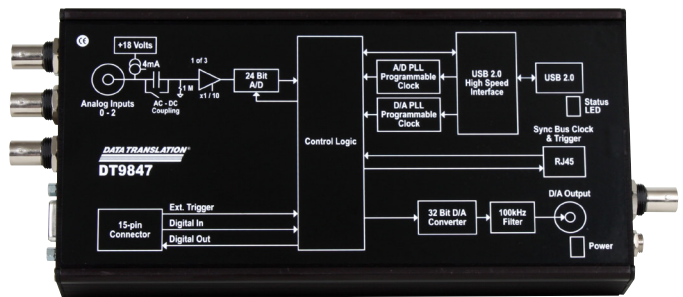

The DT9847 Series features ultra-low total harmonic distortion (THD) of 102 dB and wide dynamic range up to 123 dB for precision measurements in sound and vibration applications.

- Up to two 32-bit D/A converters
- Single value, waveform, and continuous streaming output
- Programmable output rate from 30 kS/s to 216 kS/s
- Output range of ± 10 V and ± 3 V
- Software-programmable trigger source (software trigger or external digital trigger) to start the analog output operation
- Internal clock source (shared between the analog input and analog output subsystems)
- Sync Bus (RJ45) connector for synchronizing acquisition on up to four DT9847 Series modules

Supported Operating Systems

- Windows® 10/8/7/Vista® 32/64-bit

Analog Input Channels

The DT9847-2-2 module provides two analog input channels and the DT9847-3-1 module provides three analog input channels. These are single-ended channels; IEPE sensors can be connected to these inputs. Software-selectable gains of 1 and 10 provide effective input ranges of ± 10 V and ± 1 V. The DT9847 Series modules use 24-bit Delta-Sigma analog-to-digital converters (ADCs) that provide anti-aliasing filters based on the clock rate. These filters remove aliasing, which is a condition where high frequency input components erroneously appear as lower frequencies after sampling.

DT9847 Series modules can acquire a single value from a single analog input channel, a single value from all the analog input channels simultaneously, or multiple values from a group of analog input channels.

IEPE Functions

Applications that require accelerometer, vibration, noise, or sonar measurements often use IEPE sensors. IEPE conditioning is built-in to the analog input circuitry of the DT9847 Series modules. The modules support the following software-programmable IEPE functions for each of the analog inputs:

- **Excitation current source** — The DT9847 Series modules provide an internal excitation current source of 4 mA. Enable or disable the use of a 4 mA, internal excitation current source using software. By default, the excitation current source is disabled.
- **Coupling type** — Select whether AC coupling or DC coupling is used. By default, DC coupling is selected for the DT9847 Series modules.

Programmable A/D Clock

The DT9847 Series modules support an internal clock, which is derived from the USB clock. Use software to specify the internal clock source and the frequency at which to pace the input and output operations and to start the sample clock. The sampling frequency ranges from 1 kHz to 216 kHz.

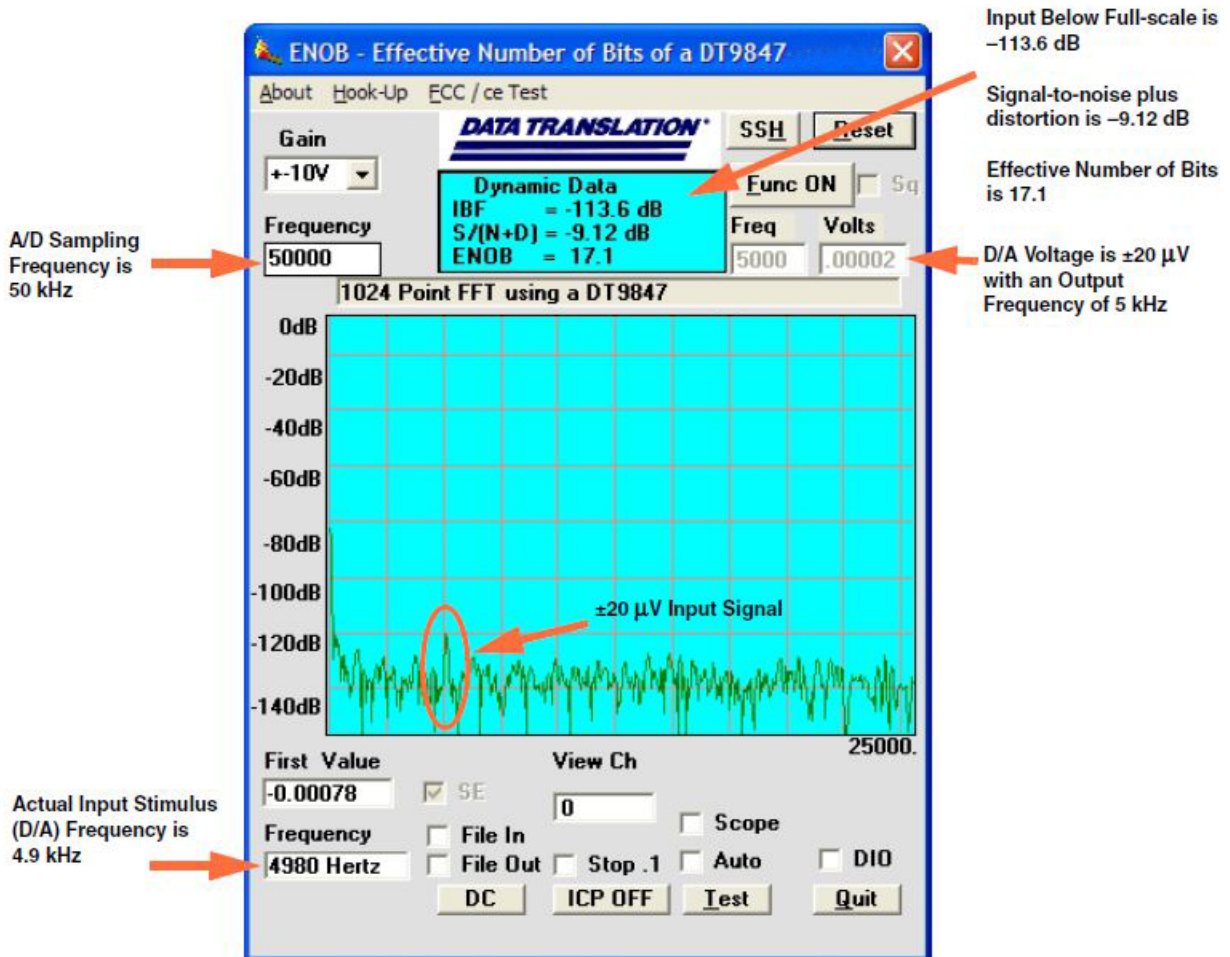

Exceptional performance of the DT9847 is illustrated in the FFT diagram. The D/A stimulus signal of ±20 μV at 4.98 kHz is fed back into the A/D input. The A/D is sampling at 50 kS/s/ch.

The IBF (input Below Full Scale) is -113.6 dB, the signal-to-noise plus distortion is -9.12 dB, the ENOB (Effective Number of Bits) is 17.1.

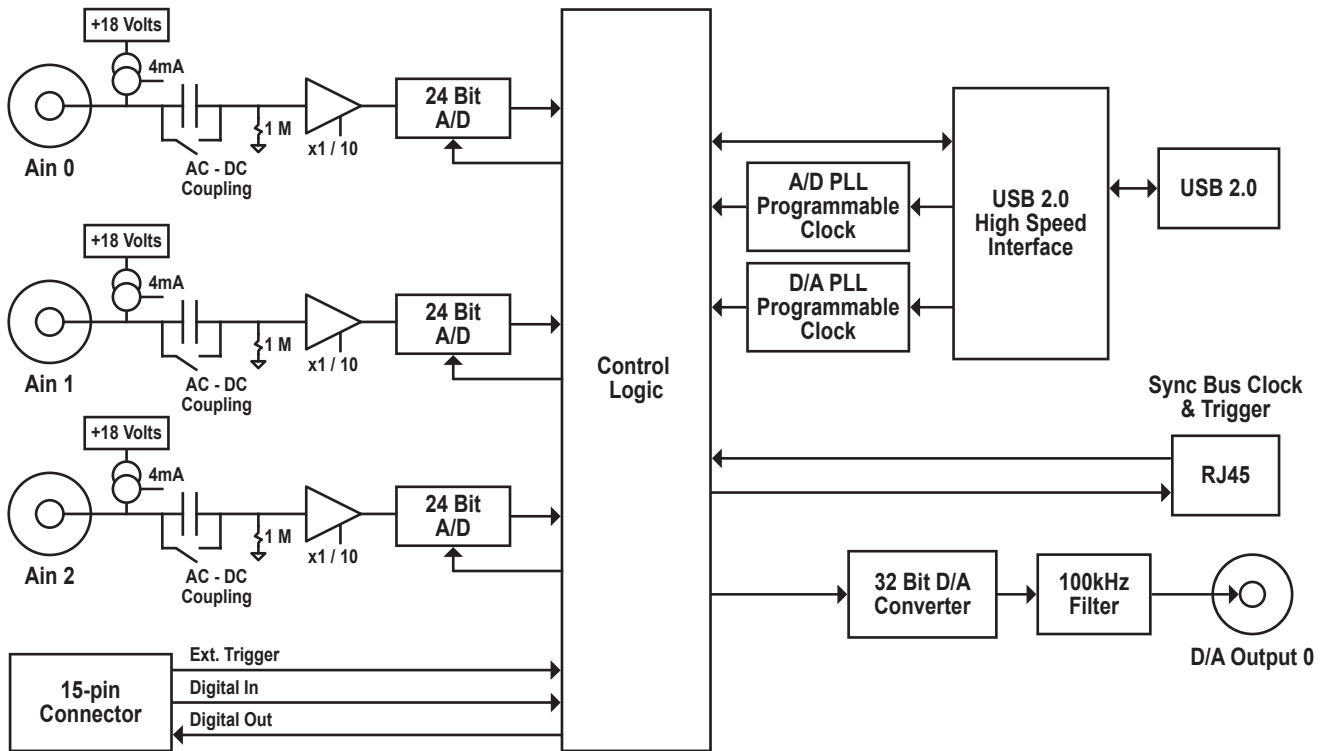

Block Diagram of DT9847-3-1 module.

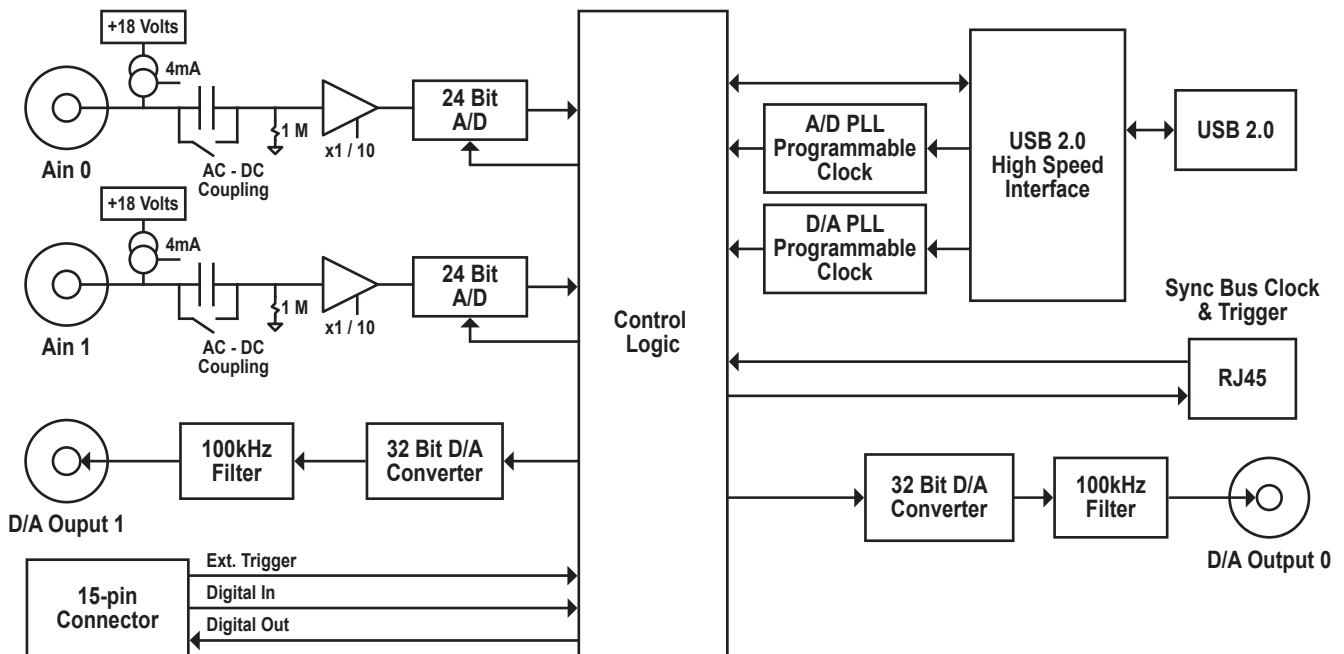

Block Diagram of DT9847-2-2 Module.

Analog Input Conversion Modes

DT9847 Series modules support single-value, single-values, and continuous scan conversion modes:

- **Single-Value Operations** — Specify the analog input channel and the gain to be used. The module acquires the data from the specified channel and returns the data immediately.
- **Single-Values Operations** — Use a single-values operation to read a single value from all the analog input channels simultaneously using one software call. Specify the analog input subsystem and the gain for the channels (not the channels themselves). The module then acquires a value from each input channel simultaneously; the data is returned as an array of input values.
- **Continuous Scan Mode** — Continuous scan mode takes full advantage of the capabilities of the DT9847 Series modules. Specify a channel list, clock frequency, start trigger, reference trigger, post-trigger scan count, and buffer using software.

On the DT9847-2-2 module, you can enter up to two entries in the channel list (analog input channels 0 and 1). On the DT9847-3-1 module, you can enter up to three entries in the channel list (analog input channels 0 to 2). Using software, specify the channels you want to sample in sequential order

When the start trigger is detected, the module simultaneously acquires pre-trigger data from all of the input channels specified in the channel list. The sampled data is placed in the allocated buffer(s). When the reference trigger occurs, pre-trigger data acquisition stops and post-trigger acquisition starts. The operation continues until the number of samples specified for the post-trigger scan count is acquired; at that point, the operation stops. The conversion rate is determined by the frequency of the input sample clock.

Using software, you can stop a scan by performing either an orderly stop or an abrupt stop. In an orderly stop, the module finishes acquiring the current buffer, stops all subsequent acquisition, and transfers the acquired data to host memory; any subsequent triggers are ignored. In an abrupt stop, the module stops acquiring samples immediately; the current buffer is not completely filled, it is returned to the application only partially filled, and any subsequent triggers are ignored.

Input Triggers

A trigger is an event that occurs based on a specified set of conditions. On the DT9847 Series modules, a start trigger source and a reference trigger source can be specified. Pre-trigger acquisition starts when the start trigger event occurs. When the reference trigger occurs, pre-trigger data acquisition stops and post-trigger acquisition starts. Post-trigger acquisition stops when the number of samples specified for the post-trigger scan count has been reached.

Start Trigger Sources

The DT9847 Series modules support the following trigger sources for the start trigger:

- **Software trigger** — A software trigger event occurs when you start the analog input operation (the computer issues a write to the module to begin conversions). Using software, specify the start trigger source as a software trigger.
- **External digital (TTL) trigger** — An external digital (TTL) trigger event occurs when the module detects a rising- or falling-edge transition on the signal connected to the External Trigger pin (pin 13) of the Digital I/O and External Trigger connector on the module. Using software, specify the trigger source as an external, positive digital (TTL) trigger or an external, negative digital (TTL) trigger.

Note: If you configure the synchronization mode as slave, the Sync Bus connector accepts trigger and clock signals from the master; you cannot use the Ext Trig connector on the slave module.

- **Analog threshold trigger** — The start trigger event occurs when the signal attached to a specified analog input channel in the channel list rises above or falls below a user-specified threshold level. Using software, specify the following parameters:
 - **Start Trigger source** — Specify a positive (low-to-high transition) threshold trigger if you want to trigger when the signal rises above a threshold level, or a negative (high-to-low transition) threshold trigger if you want to trigger when the signal falls below a threshold level.
 - **Threshold channel** — Specify any one of the analog input channels that are included in the channel list as the threshold input channel.
 - **Threshold level** — Specify a value between ± 10 V for a gain of 1 or ± 1 V for a gain of 10 as the threshold level.
- **Sync Bus trigger** — When multiple DT9847 Series modules are connected together using the Sync Bus (RJ45) connector, you can use the Sync Bus trigger as the start trigger of the slave module by setting the synchronization mode of module to Slave. In this configuration, any other start trigger for the slave module is ignored.

Reference Trigger Sources

The DT9847 Series modules support the following sources for the reference trigger:

- **External digital (TTL) trigger** – The reference trigger event occurs when the module detects a rising- or falling-edge transition on the signal connected to the External Trigger pin (pin 13) of the Digital I/O and External Trigger connector on the module.
- **Analog threshold trigger** – The reference trigger event occurs when the signal attached to a specified analog input channel in the channel list rises above or falls below a user-specified threshold value. Using software, specify a positive (low-to-high transition) threshold trigger or a negative (high-to-low transition) threshold trigger, the analog input channel to use as the threshold channel, and the threshold level.
- **Sync Bus trigger** – When multiple DT9847 Series modules are connected together using the Sync Bus (RJ45) connector, set the reference trigger of a slave DT9847 Series module to Sync Bus to receive a Sync Bus trigger from one of the other modules to stop pre-trigger and start post-trigger acquisition.

Analog Output Channels

The DT9847-3-1 module supports one analog output channel (0) through analog output subsystem 0. The DT9847-2-2 module supports two analog output channels (0 and 1) through analog output subsystem 0. The DT9847 Series modules provide a two-pole, 100 kHz Butterworth filter to prevent noise from interfering with the output signal.

The DT9847 Series modules can output bipolar analog output signals in the range of ± 3 V and ± 10 V, with a gain of 1. The resolution of the analog output channel is fixed at 32-bits.

The clock frequency for the D/A output clock on the DT9847 Series modules can be programmed to a value between 30 kHz and 216 kHz.

Use software to specify an internal clock source and to specify the clock frequency for the analog output subsystem.

Due to the group delay of the Delta-Sigma D/A converter, the DT9847 Series modules require 36 clock pulses once the analog output sample clock is started before the first D/A conversion is completed.

Output Conversion Modes

The DT9847 Series modules support single-value, waveform, and continuous analog output operations.

Single-Value Mode

Single-value mode is the simplest to use but offers the least flexibility and efficiency. Use software to specify the analog output channel that you want to update, and the value to output from that channel. The value is output from the specified channel immediately. For a single-value operation, you cannot specify a clock source, trigger source, or buffer. Single-value operations stop automatically when finished; you cannot stop a single-value operation.

Waveform Generation Mode

Waveform generation mode is supported on both the DT9847 Series modules. In this mode, a waveform, which is specified in a single buffer, is output repetitively. The waveform pattern can range from 2 to 8192 samples if you are using one analog output channel or from 2 to 4096 if you are using two analog output channels.

The host computer transfers the entire waveform pattern to the 8 kilosample output FIFO on the module when the trigger is detected. The module starts writing output values to the analog output channels at the specified clock rate. The module recycles the data, allowing you to output the same pattern continuously without any further CPU or USB bus activity.

When it reaches the end of the FIFO, the module returns to the first location of the FIFO and continues outputting the data indefinitely until you stop it.

Continuous Analog Output Operations

Use continuously paced analog output mode to continuously output buffered values to the analog output channel at a specified clock frequency. The DT9847 Series modules support the ability to start continuous analog output operations and continuous analog input operations simultaneously.

Use software to fill the output buffer with the values that you want to write to the analog output channels. For example, if your output channel list contains analog output channels 0 and 1, specify the values in the output buffer as follows: the first output value for analog output channel 0, the first output value for analog output channel 1, the second output value for analog output channel 0, the second output value for analog output channel 1, and so on.

When it detects a trigger, the module starts writing the values from the output buffer to the channels specified in the output channel list at the specified clock frequency. The operation repeats continuously until all the data is output from the buffers or you stop the operation.

Output Triggers

The DT9847 Series modules support the following trigger sources for starting analog output operations:

- **Software trigger** — A software trigger event occurs when you start the analog output operation (the computer issues a write to the module to begin conversions). Using software, specify the trigger source for D/A subsystem 0 as a software trigger.
- **External digital (TTL) trigger** — An external digital (TTL) trigger event occurs when the module detects a rising- or falling edge transition on the signal connected to the External Trigger pin (pin 13) of the Digital I/O and External Trigger connector on the module. Using software, specify the trigger source for D/A subsystem 0 as an external, positive digital (TTL) trigger or an external, negative digital (TTL) trigger.

Note: If you configure the synchronization mode as slave, the Sync Bus connector accepts trigger and clock signals from the master; you cannot use the Ext Trig BNC connector on the slave module.

- **Sync Bus trigger** — When multiple DT9847 Series modules are connected together using the Sync Bus (RJ45) connector, you can use the Sync Bus trigger as the start trigger of the slave module by setting the synchronization mode of module to Slave. In this configuration, any other start trigger for the slave module is ignored.

Digital I/O Lines

The DT9847 Series modules support one digital input port, consisting of 4 digital input lines (lines 0 to 3) and one digital output port, consisting of 4 digital output lines (lines 0 to 3). The resolution is fixed at 4 bits.

You can read all 4 digital input lines or write all 4 digital output lines with a single-value digital I/O operation. A digital line is high if its value is 1; a digital line is low if its value is 0. On power up or reset, a low value (0) is output from each of the digital output lines.

Triggering Acquisition on Multiple Modules

Acquisition on multiple DT9847 Series modules can be synchronized using the Sync Bus (RJ45) connector.

The internal clock on the DT9847 Series modules when the synchronization mode is none, is derived from the USB clock and provides the timing for both the analog input and analog output subsystems on the module.

You can start acquisition on multiple modules by connecting all modules to a shared external trigger input. When triggered, the modules start acquiring data at the same time. Using this connection scheme, the measurements of one module may not be synchronous with the measurements of another module due to logic delays in the clocking and USB circuitry.

Synchronizing Acquisition on Multiple DT9847 Series Modules

DT9847 Series modules provide a Sync Bus (RJ45) connector that can be used to connect and synchronize multiple DT9847 Series modules. In this scheme, one module is the master and the other modules are the slave. You specify the synchronization mode (master, slave, or none) of the A/D subsystem using software.

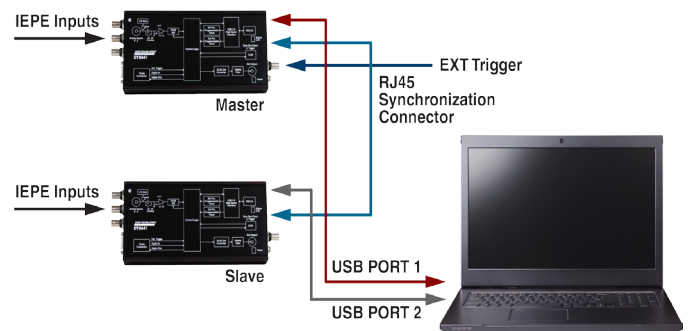

A Master/Slave connection allows two modules to operate in perfect synchronization for up to 6 IEPE inputs.

When configured as a master, the Sync Bus connector outputs trigger and clock signals. When configured as a slave, the Sync Bus connector accepts trigger and clock signals from the master; the start trigger source on the slave module is ignored in this configuration since the Sync Bus is used as the start trigger.

When configured as none (the default mode), the DT9847 Series module uses the USB clock instead of the Sync Bus connector. The synchronization mode remains set until changed or until the application exits.

You can connect multiple modules in one of two ways. The following diagram shows how to connect a maximum of two DT9847 Series modules by daisy chaining them together through the Sync Bus connector.

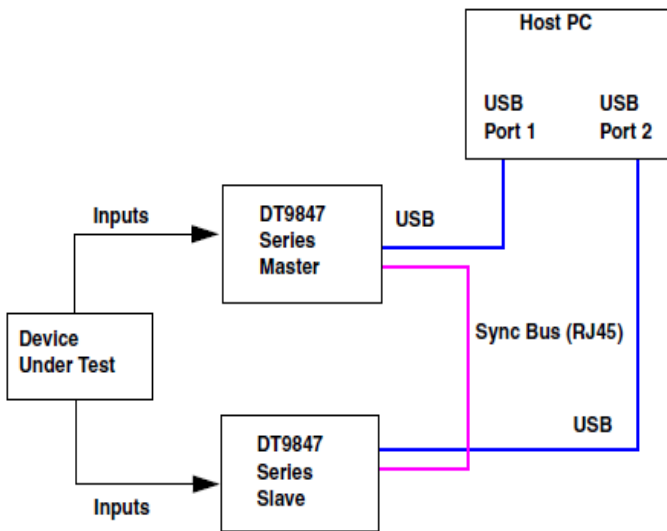

Synchronizing two DT9847 Series modules by daisy chaining the RJ45 connectors (shown using external trigger)

The following diagram shows how to connect a maximum of four DT9847 Series modules by using an RJ45 distribution panel, such as an EP386, where the panel contains four RJ45 connectors that are wired in parallel.

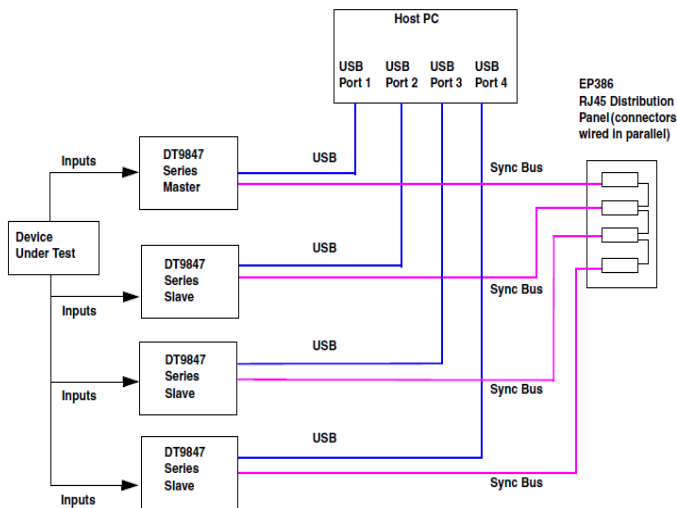

Synchronizing four DT9847 Series modules by using the EP386 RJ-45 Distribution Panel.

When synchronizing multiple modules, start the slave modules before starting the master module. When the master module is triggered (using any of the supported trigger sources), both the master and the slave modules start acquiring data at the same time (within one A/D conversion of the clock). Note that you can set the clock rate to be the same or different on each module.

QuickDAQ

QuickDAQ allows you to acquire and display from all Data Translation USB and Ethernet data acquisition devices that support analog input streaming. Combine QuickDAQ with Data Translation hardware to acquire data, record data to disk, display the results in both a plot and digital display, and read a recorded data file. Be productive right out of the box with this powerful data logging software. Data can be exported to other applications like Microsoft Excel® and The Mathworks MATLAB® for more advanced analysis. Two additional options can be purchased to add FFT analysis capabilities to the base package.

Key Features

- **QuickDAQ Base Package (Free)**
 - Ready-to-measure application software
 - Configure, acquire, log, display, and analyze your data
 - Customize many aspects of the acquisition, display, and recording functions to suit your needs
- **FFT Analysis Option (License Required)**
 - Includes all the features of the QuickDAQ Base Package
 - Perform single-channel FFT operations including:
 - ◇ Auto Spectrum
 - ◇ Spectrum
 - ◇ Power Spectral Density
 - Configure and view dynamic performance statistics
 - Supports Hanning, Hamming, Bartlett, Blackman, Blackman Harris, and Flat Top response windows
- **Advanced FFT Analysis Option (License Required)**
 - Includes all the features of the QuickDAQ Base Package and FFT Analysis Package
 - Perform 2-channel FFT operations including:
 - ◇ FRF
 - ◇ Cross-Spectrum
 - ◇ Cross Power Spectral Density
 - ◇ Coherence
 - ◇ Coherent Output Power
 - Supports real, imaginary, and Nyquist display functions
 - Additional FFT analysis functions supported: Exponential, Force, Cosine Taper
 - Save data to .uff file format

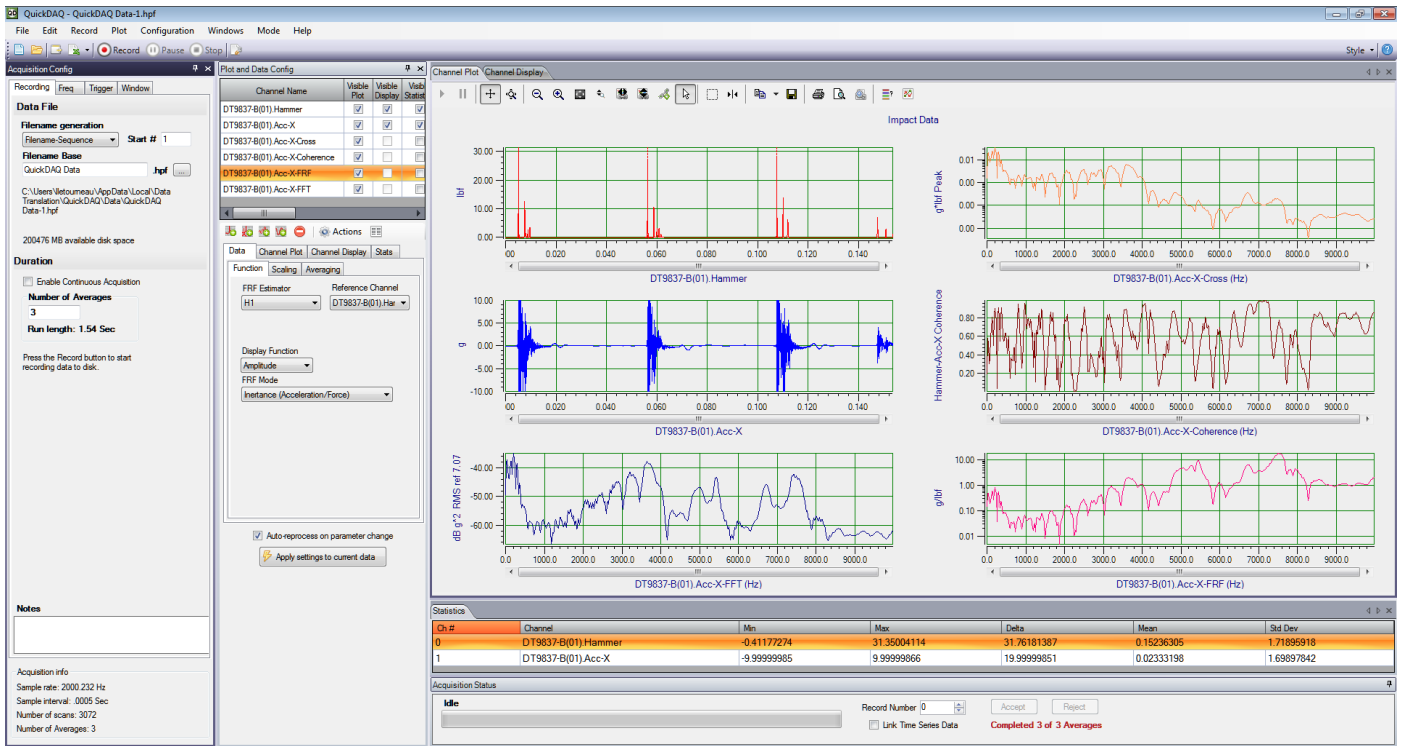

QuickDAQ with Advanced FFT Analysis Option.

Software Options

The following software is available for use with this module and is provided on the Data Acquisition Omni CD:

- **Device Driver** — The device driver allows you to use the DAQ module with any of the supported software packages or utilities.
- **Calibration Utility** — This utility allows you to calibrate features of the DAQ module.
- **DT-Open Layers® for .NET Class Library** — Use this class library if you want to use Visual C#® or Visual Basic® for .NET to develop application software for a DAQ module using Visual Studio® 2003-2012; the class library complies with the DT-Open Layers standard.
- **DataAcq SDK** — Use the DataAcq SDK to use Visual Studio 6.0 and Microsoft® C or C++ to develop application software for a DAQ module using Windows 10/8/7/Vista/XP 32/64-bit; the DataAcq SDK complies with the DT-Open Layers standard.
- **DAQ Adaptor for MATLAB** — Data Translation's DAQ Adaptor provides an interface between the MATLAB® Data Acquisition (DAQ) toolbox from The MathWorks™ and Data Translation's DT-Open Layers architecture.
- **LV-Link** — Data Translation's LV-Link is a library of VIs that enable LabVIEW™ programmers to access the data acquisition features of DT-Open Layers compliant USB and PCI devices.

QuickDAQ Advanced FFT Function Examples

The following plots show how you can use the DT9847 module with the Advanced FFT functions in QuickDAQ to analyze data from a sweep test. Single FFT and two-channel FFT functions are shown. Two-channel FFT functions compare the spectrum of a reference channel, which outputs a stimulus, to the spectrum of a response channel, which measures the effect of the stimulus.

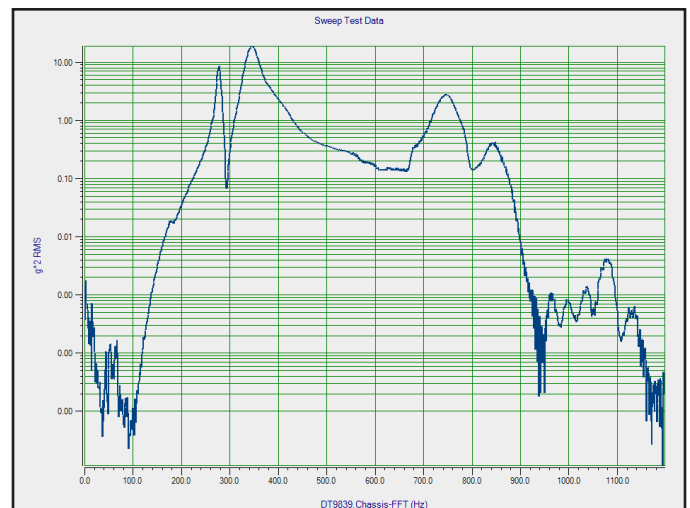

AutoSpectrum Response Channel

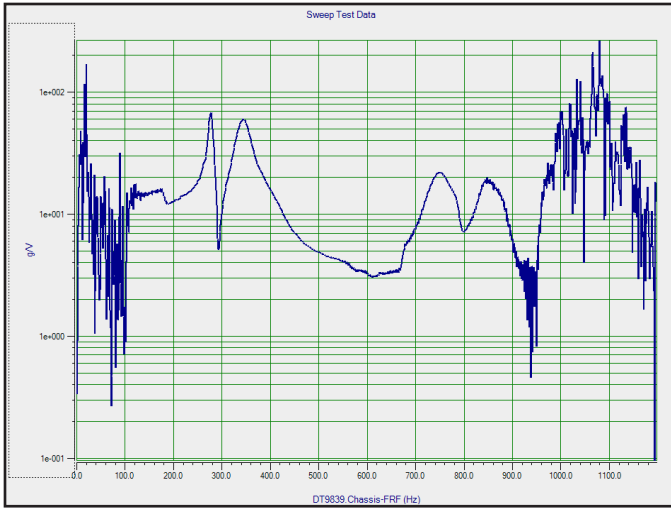

Frequency Response Function

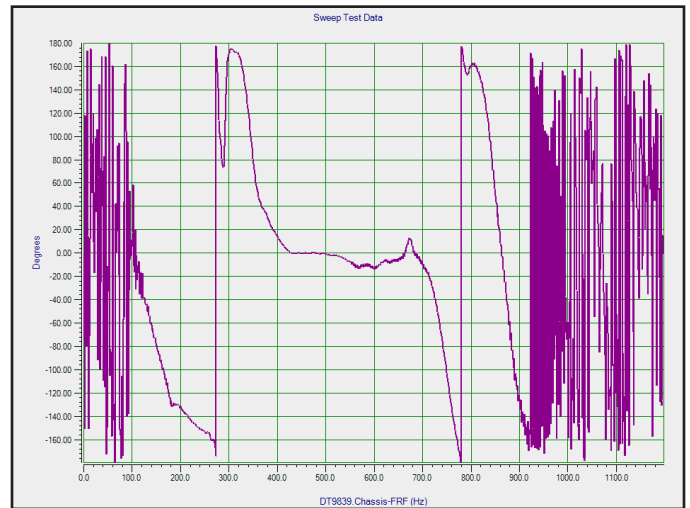

FRF - Phase

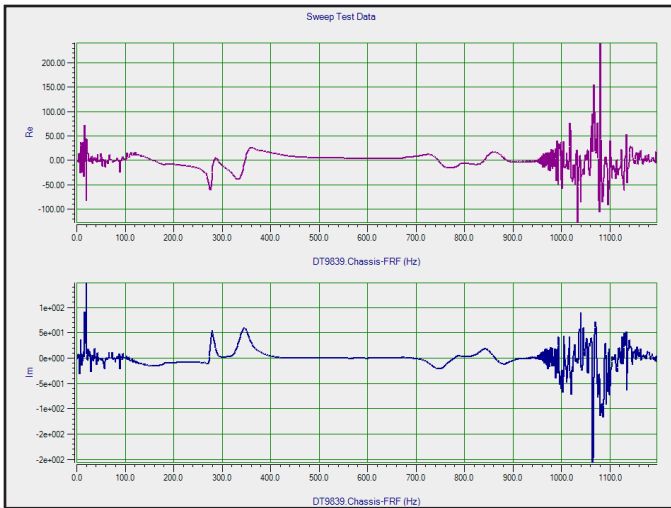

FRF - Real and Imaginary

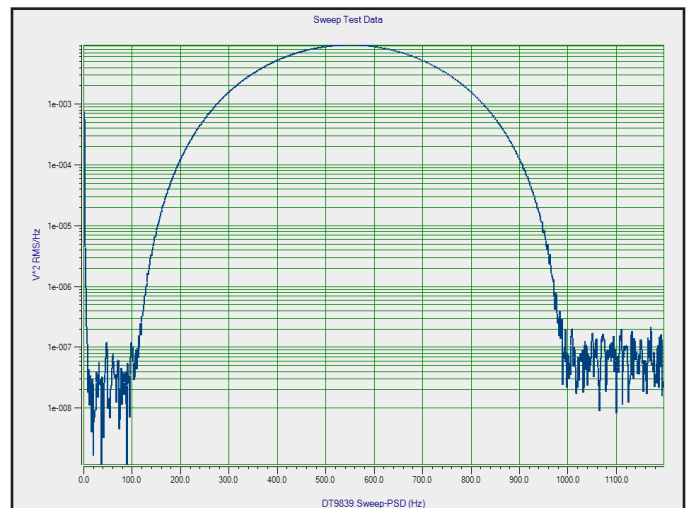

Power Spectral Density

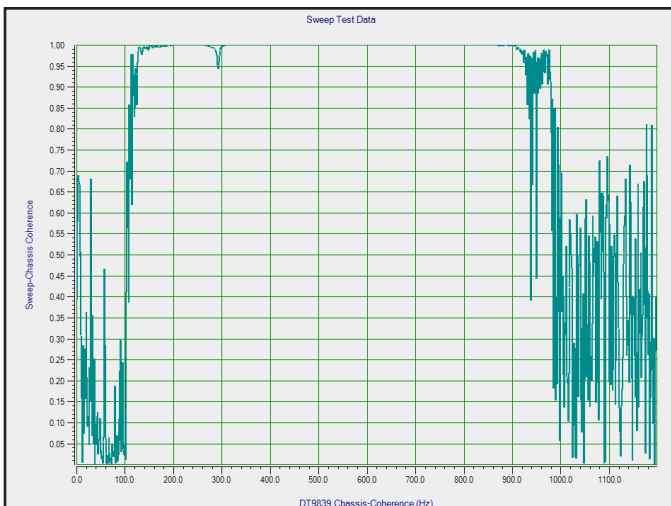

Coherence Reference Response

Cross-Series Compatibility

Virtually all Data Translation data acquisition modules are compatible with the DT-Open Layers® software standard. This means any application developed with one of Data Translation's software products can easily be upgraded to a new Data Translation module with little to no reprogramming needed.

Ordering Summary

HARDWARE

- DT9847-2-2
- DT9847-3-1

ACCESSORIES

- BNC DIN-RAIL KIT
- EP386 — RJ45 Patch Panel, contains four RJ45 connectors that are wired in parallel, to connect four modules together using the Sync Bus

FREE SOFTWARE

- QuickDAQ
- DAQ Adaptor for MATLAB
- LV-Link

OPTIONAL SOFTWARE

- QuickDAQ FFT Analysis Option (License Required)
- QuickDAQ Advanced FFT Analysis Option (License Required)