

# DT330 Series

## Low-Cost Analog Output and Digital I/O Boards for the PCI Bus

### Overview

The DT330 Series is a family of four low-cost analog output and digital I/O boards for the PCI bus. Ideal for applications requiring multiple D/A outputs and control capabilities, the DT330 Series offers four or eight analog outputs as well as 32 digital I/O lines.

### Key Features

- Four different board configurations provide a range of flexible, cost-effective options.
- Four or eight analog outputs with 12- or 16-bit resolution.
- 32 digital I/O lines for non-clocked monitoring or control of high channel count applications.
- Interrupt on bit change detection for monitoring critical signals.

### Supported Operating Systems

- Windows® 10/8/7/Vista®/XP 32/64-bit

### Analog Outputs Provide Flexibility

Available with four or eight analog outputs at 12- or 16-bit resolution, the DT330 Series analog outputs can be updated through programmed I/O at slow speeds (actual speed depends on the PC – typical update rate: 1 kS/s to 10 kS/s).

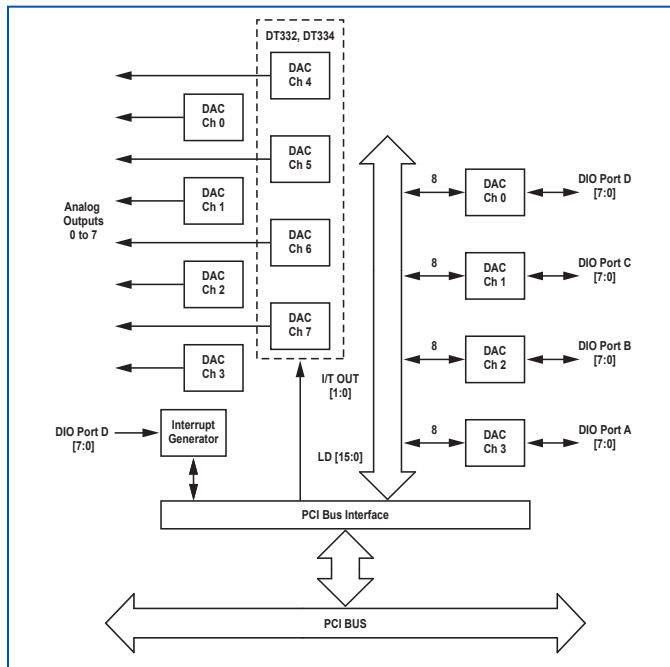

**DT330 Series Block Diagram.** Note: The DT331 and DT333 boards do not contain DAC channels 4-7. The DT331 and DT332 have 12-bit DACs, and the DT333 and DT334 have 16-bit DACs.

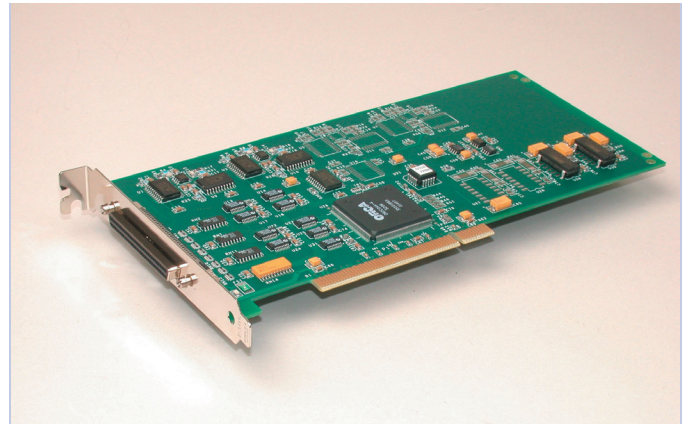

**DT330 Series boards feature either 4 or 8 channels and 32 digital I/O lines.**

The DT331 and DT332 have 12-bit analog outputs that can be set through software for ranges of  $\pm 10$  V, 0–10 V,  $\pm 5$  V, or 0–5 V. The DT333 and DT334 have 16-bit analog outputs with a fixed range of  $\pm 10$  V.

### 32 Digital I/O Channels for High-Channel-Count Requirements

Each DT330 Series board provides 32 digital I/O lines, grouped into four 8-bit ports. You can program each port for either input or output. Digital outputs are capable of driving solid-state relays (sink 24 mA and source 15 mA).

The DT330 Series boards can generate an interrupt when any of the eight digital I/O lines corresponding to one of the 8-bit digital ports changes state. This feature is useful when you want to monitor critical signals or when you want to signal the host computer to transfer data to or from the board. You can enable the interrupts on a bit-by-bit basis on this port.

Features Summary				
Analog Outputs				
Model	Channels	Resolution	Output Ranges	
DT331	4	12-bit	$\pm 10$ V, 0-10 V, $\pm 5$ V, 0-5 V	
DT332	8	12-bit	$\pm 10$ V, 0-10 V, $\pm 5$ V, 0-5 V	
DT333	4	16-bit	$\pm 10$ V	
DT334	8	16-bit	$\pm 10$ V	
Digital I/O				
Port	Lines Per Port	Type	Interrupt on Bit Change Detection	SSR Drive
A, B, C	8 bidirectional	Level-sensitive	No	Yes
D	8 bidirectional	Level-sensitive	Yes	Yes

## Easy User Connections

All signals are brought out to a dedicated 68-pin connector on the backplate of the DT330 Series board. The STP68 screw terminal panel is available to simplify connections. The EP305 cable connects the DT330 Series board to the STP68 screw terminal panel.

## Cross-Series Compatibility

Virtually all Data Translation data acquisition boards and modules are compatible with the DT-Open Layers® Class Library. This means that if your application was developed with one of Data Translation's software products, you can easily upgrade to a new Data Translation board. Little or no reprogramming is needed.

## Software Options

The following software is available for free and provided on the Data Acquisition Omni CD:

- **Device Driver** – The device driver allows you to use the PCI DAQ board with any of the supported software packages or utilities.
- **DT-Open Layers® for .NET Class Library** – Use this class library if you want to use Visual C#® or Visual Basic® for .NET to develop application software using Visual Studio® 2003-2012; the class library complies with the DT-Open Layers standard.
- **DataAcq SDK** – Use the DataAcq SDK to use Visual Studio 6.0 and Microsoft® C or C++ to develop application software using Windows 10/8/7/Vista/XP 32/64-bit; the DataAcq SDK complies with the DT-Open Layers standard.
- **DAQ Adaptor for MATLAB** – Data Translation's DAQ Adaptor provides an interface between the MATLAB® Data Acquisition (DAQ) toolbox from The MathWorks™ and Data Translation's DT-Open Layers architecture.
- **LV-Link** – Data Translation's LV-Link is a library of VIs that enable LabVIEW™ programmers to access the data acquisition features of DT-Open Layers compliant USB and PCI devices.

## User's Manual

Each DAQ board or module includes a comprehensive user's manual that provides getting started and reference information. The manual is provided in electronic (PDF) format on the Data Acquisition Omni CD, included with the module and also available online.

## Technical Support

Application engineers are available by phone and email during normal business hours to discuss your application requirements. Extensive product information, including drivers, example code, pinouts, a searchable Knowledge Base, and much more, is available 24 hours a day on our web site at [www.mccdaq.com](http://www.mccdaq.com).

For more information about the DT330 Series, including specifications, please visit [www.mccdaq.com/Products/PCI-Data-Acquisition/DT330-Series](http://www.mccdaq.com/Products/PCI-Data-Acquisition/DT330-Series).

## Ordering Summary

### HARDWARE

- **DT331** – PCI 4-channel, 12-bit analog output and digital I/O board
- **DT332** – PCI 8-channel, 12-bit analog output and digital I/O board
- **DT333** – PCI 4-channel, 16-bit analog output and digital I/O board
- **DT334** – PCI 8-channel, 16-bit analog output and digital I/O board

### ACCESSORIES

- **EP305** – 68-pin, 2 meter, shielded cable
- **STP68** – Screw Terminal Panel

### FREE SOFTWARE

The following software is available as a free download from our website:

- **LV-Link** – Access the power of Data Translation boards through LabVIEW™
- **DAQ Adaptor for MATLAB** – Access the analysis and visualization tools of MATLAB®.