

CPCI-DDA02/16, 04/16, 08/16

CompactPCI-bus Compatible, 2, 4, & 8-Channel, 16-Bit Analog Output Board with 48 Digital I/O bits



Features

- 2, 4, & 8 channel analog output models
- One D/A per channel
- 16-bit D/A resolution (1 in 65,536)
- 48 bits of high output digital I/O
- High current digital outputs
- Digital I/O section is connector compatible with all ComputerBoards 50-pin based signal conditioning
- Unique *in-system* calibration function allows the removal of wiring IR errors
- Fully Plug-and-Play
- Fully Autocalibrating

Block Diagram

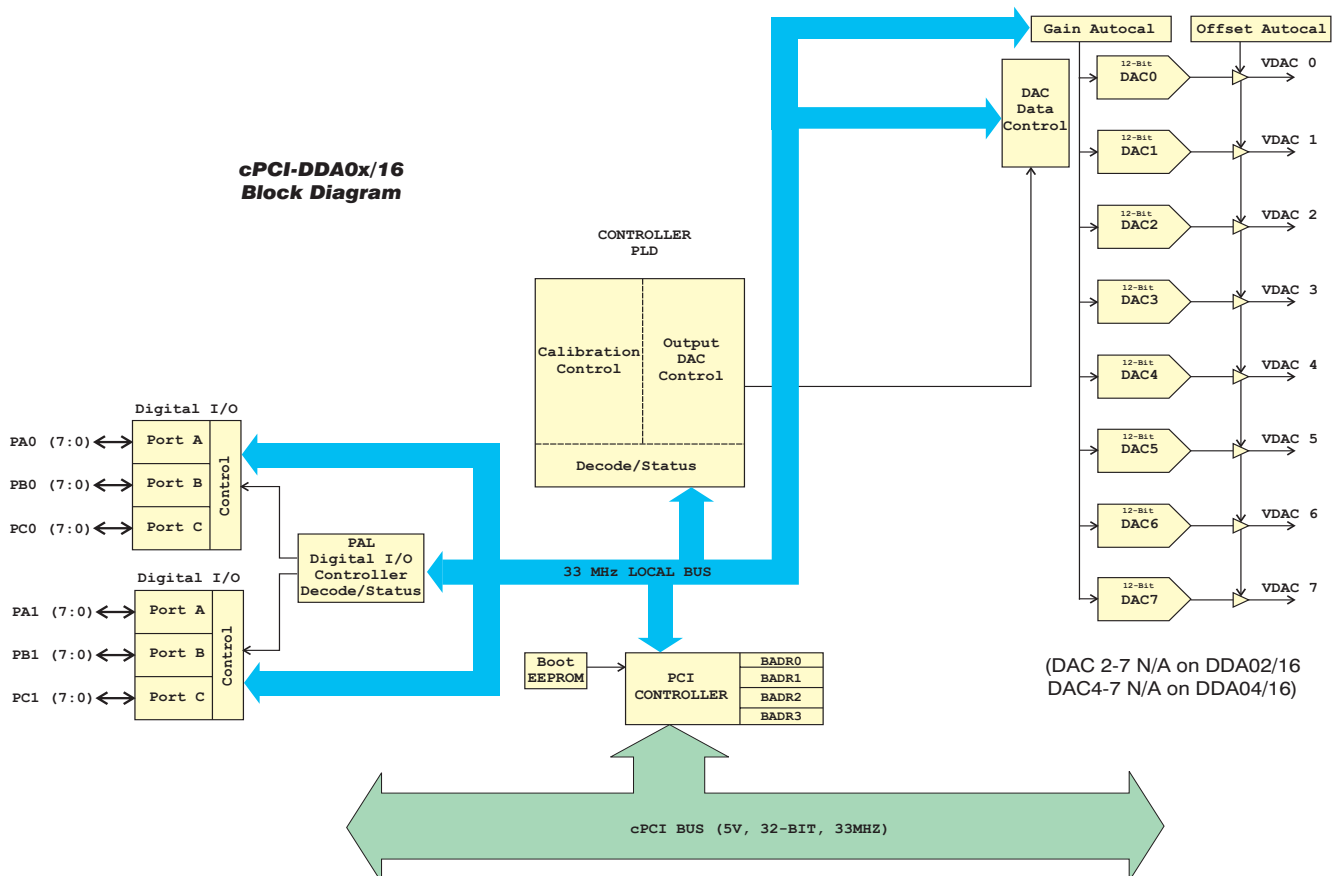

Functional Description

The CPCI-DDA0x/16 multifunction analog output and digital I/O boards set a new standard for high performance, analog output on the CompactPCI-bus. The CPCI-DDA0x/16 family consists of three models with either 2, 4, or 8 output channels and 48 bits of digital I/O. The CPCI-DDA0x/16 analog output channels may be updated independently or simultaneously.

The CPCI-DDA0x/16 is completely plug-and-play. There are no switches, jumpers or potentiometers on the board. All board addresses, interrupt channels, etc. are set by your computer's plug-and-play software. Even calibration is performed via software by using on-board trim D/A converters. A powerful *in-system* calibration capability allows the board to be calibrated after installation, and eliminates connection wire and connector IR errors. (For more details on our digital calibration techniques, please see our calibration tutorial on page 270).

Analog Outputs

The CPCI-DDA0x/16 provides two, four, or eight channels of 16-bit analog output (one part in 65536). Each channel is implemented with an independent D/A converter, and the analog outputs are updated under software control. Software selectable output ranges of 0-10V, 0-5V, 0-2.5V, $\pm 10V$, $\pm 5V$, and $\pm 2.5V$ are provided and channels may be set at

different ranges. The D/A outputs provide rated accuracy to ± 5 mA, are short circuit protected (25 mA limit) and are cleared to 0 volts on power up or reset.

The table below details the input ranges and resolutions for the available input configurations and gains.

Bipolar		Unipolar	
Range	Resolution	Range	Resolution
$\pm 10V$	305 μV	0-10V	152.6 μV
$\pm 5V$	152.6 μV	0-5V	76.29 μV
$\pm 2.5V$	76.29 μV	0-2.5V	38.15 μV

Parallel Digital I/O

The CPCI-DDA0x/16 provide 48 bits of parallel, digital I/O in the form of four 8-bit ports and four 4-bit ports. This digital capability is based on an on-board, high output current emulation of the 82C55 mode 0 and allows each of the ports to be set independently as input or output. On power up or reset, the ports default to the input state (high impedance). The digital I/O section of the board is fully connector compatible with all of ComputerBoards 50-pin digital signal conditioning boards.

I/O Connector & Cables

All I/O signals are brought through a 100-pin high-density connector. The standard C100HD50-X series cable splits the 100 pins into two separate 50-pin cables. The first 50-pin cable contains pins 1-50, while the second carries pins 51-100 keeping the analog signals in one cable and the digital in another. This configuration minimizes noise in the analog signal lines and greatly simplifies field wiring as well as connections to external signal conditioning products. The C100HD50-X series cable then connects to either the SCB-50 screw connection box (one required) or the CIO-MINI50 (two required).

The C100HDS-X series shielded cable provides greater noise immunity and is compatible with the SCB-100 screw connection box.

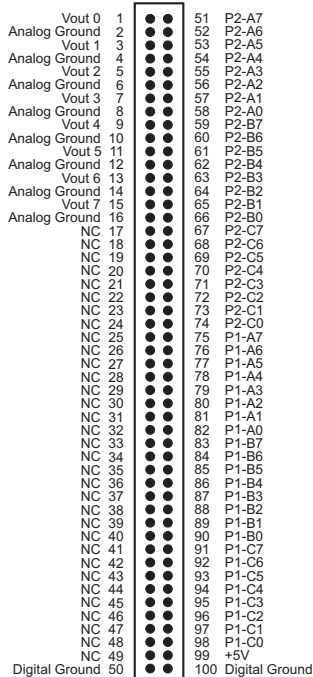

Connector Diagram

Software

All CPCI-DDA0x/16 boards come complete with ComputerBoards' powerful *InstaCal*™ software package. *InstaCal* is a complete installation, calibration and test program for ComputerBoards data acquisition and control boards. Complete with extensive error checking, *InstaCal* guides you through installation and setup of your data acquisition board and creates the board configuration file for use by your program or application software package. *InstaCal* is described in detail within the software section of this website.



InstaCal provides installation, calibration and test functions for all of our boards!

The CPCI-DDA0x/16 boards are fully supported by ComputerBoards' powerful Universal Library. Universal Library is a complete set of I/O libraries and drivers for all of our boards, in all Windows based languages. When using the Universal Library you can switch boards or even programming languages and the syntax remains constant. For details on Universal Library, please refer to this website's software section.

The CPCI-DDA0x/16 boards are fully supported by a wide variety of applications software packages including SoftWIRE™, DAS-Wizard™, (and DAS-Wizard Pro™), HP VEE®, HP VEE Lab and LabVIEW™. For further details on these, as well as a variety of other software packages, please refer to the software section of this website.

CPCI-DDA0x/16 Specifications

Analog Output:

D/A convertor type	Voltage Output
Resolution	16-bits
Number of channels	8, 4 or 2 depending on model
Output Ranges	$\pm 10V$, $\pm 5V$, $\pm 2.5V$, $0 - 10V$, $0 - 5V$, $0 - 2.5V$. Each channel independently programmable.
Data transfer modes	Programmed I/O.
Offset error	± 1.5 LSB (calibrated)
Gain error	± 1.5 LSB (calibrated)
Differential nonlinearity	± 0.5 LSB typ., ± 1 LSB max (over temp)
Integral nonlinearity	± 0.5 LSB typ., ± 4 LSB max (over temp)
Monotonicity	16-bits
D/A Gain drift	± 0.1 ppm/ $^{\circ}C$
D/A Offset drift	± 0.5 ppm/ $^{\circ}C$
Throughput	PC dependent
Settling time	20 μ s max (20V step to ± 1.5 LSB) 12 μ s typ (20V step to ± 1.5 LSB)
Slew Rate	2.5 V/ μ s
Current Drive	± 5 mA
Output short-circuit duration	25 mA indefinite
Output coupling	DC
Output impedance	0.011 ohms max
In-system calibration range	In-system calibration can compensate for connector/cable resistance up to 7 ohms
Miscellaneous	Double buffered output latches Update DACs individually or simultaneously (software selectable)
Power up and reset state	all DAC's cleared to 0 volts

Digital Input / Output

Number of channels	48 I/O
Configuration	4 banks of 8, 4 banks of 4, programmable by bank as input or output
Port configurations	Dual 8255 mode 0 emulation
Digital Interface chips	Output: 74S244 Input: 74LS373
Output High	2.4 volts @ -15mA min
Output Low	0.5 volts @ 64 mA min
Input High	2.0 volts min, 7 volts absolute max
Input Low	0.8 volts max, -0.5 volts absolute min
Power On / Reset State	All ports to input mode

Power consumption

CPCI-DDA08/16

+5V Operating	1.8A typical, 2.2A max
+12V	not used
-12V	not used

CPCI-DDA04/16

+5V Operating	1.6A typical, 2.1A max
+12V	not used
-12V	not used

CPCI-DDA02/16

+5V Operating	1.4A typical, 2.0A max
+12V	not used
-12V	not used

Environmental

Operating temp range	0 to 70 $^{\circ}C$
Storage temp range	-40 to 100 $^{\circ}C$
Humidity	0 to 90% non-condensing

Auto-Calibration / Self-Calibration

In keeping with general plug-and-play standards, the CPCI-DDA0x/16 boards have no switches, jumpers or potentiometers. *Auto-calibration* is performed with trim D/A converters.

The calibration factors that control the digital trim components are stored in EEPROM on the board. You can remove the board from one computer, install it in another, and it will still provide calibrated data.

Signal Conditioning & Accessories

Analog Signal Conditioning

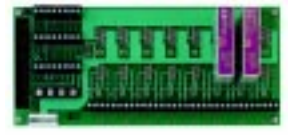

ISO-DA02/P* 2-channel ISO-5B module rack connects a ISO-5B module to each analog output channel.

ISO-DA04/P* 4-channel ISO-5B module rack connects a ISO-5B module to each analog output channel.

ISO-DA08/P* 8-channel ISO-5B module rack connects a ISO-5B module to each analog output channel.

Solid State I/O Modules & Racks

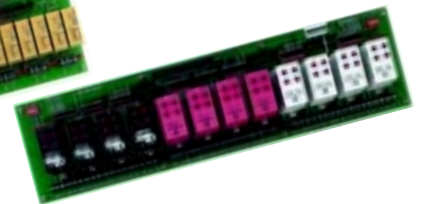

SSR-RACK48* 48 channel solid state I/O module rack.

SSR-RACK24* 24 channel solid state I/O module rack.

Electromechanical Relays

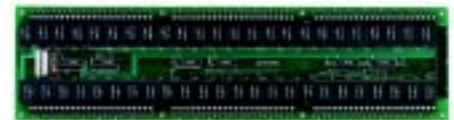

CIO-SERB48* 48 channel relay rack with 10 Amp, socketed and field replaceable Form C relays.

CIO-ERB48* 48 channel relay rack with 6 Amp, Form C relays.

CIO-ERB24* 24 channel relay rack with 6 Amp, Form C relays

CIO-SERB24* 24 channel fault detecting relay rack with 10 Amp, socketed and field replaceable Form C relays.

Screw Terminal Boards

Screw Terminal Accessory Boards and Boxes



SCB-Series Screw Connection Box

The 100-pin connector is compatible with the C100HD50-X series cable and the SCB-50 (1 required). The C100HDS-X series shielded cable provides maximum noise immunity and is compatible with the SCB-100 screw terminal interface box.

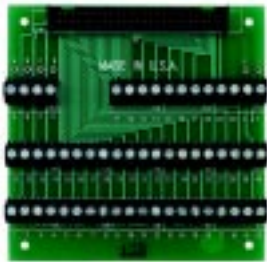

CIO-MINI-50 Screw Terminal Board

The 100-pin connector is compatible with the C100HD50-X series cable and the CIO-MINI50 (2 required).

Ordering Guide

CPCI-DDA02/16

2-channel, 16-bit D/A & high-current digital I/O board for PCI-bus computers.

CPCI-DDA04/16

4-channel, 16-bit D/A & high-current digital I/O board for PCI-bus computers.

CPCI-DDA08/16

8-channel, 16-bit D/A & high-current digital I/O board for PCI-bus computers.



The CIO-MINI50 is available with detachable screw terminals. These terminals simplify field wiring and board replacements. To specify detachable screw terminals order the CIO-MINI50/DST

SoftWIRE™ *Graphical Programming for Visual Basic*

The power and flexibility of syntactical programming

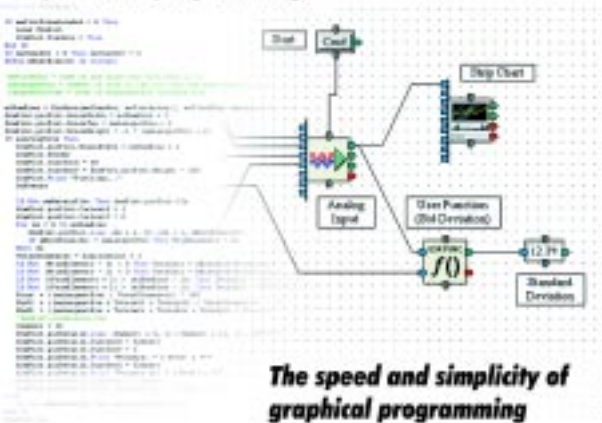

Introducing SoftWIRE™ *Graphical Programming in Visual Basic®*

Syntactical programming has been around since the early days of computers. More recently, graphical programming languages have been introduced and are now a popular alternative to writing hard core, text-based syntax. What's been lacking is an easy way to combine the speed and ease of use of graphical programming with the flexibility and efficiency of writing code in an industry standard language. Until now—Introducing SoftWIRE.