

**DATA TRANSLATION**<sup>®</sup>  
A MEASUREMENT COMPUTING COMPANY

UM-24789-H

**DT9838**  
**User's Manual**

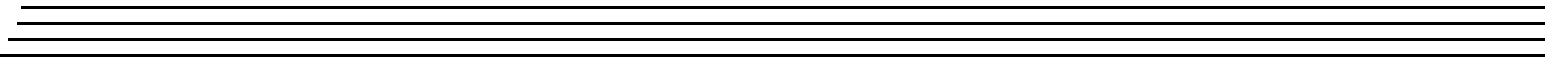
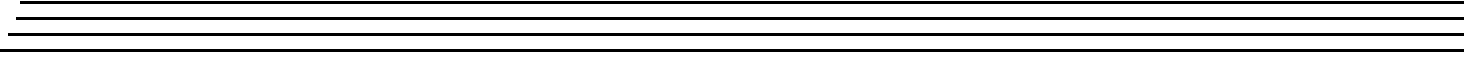
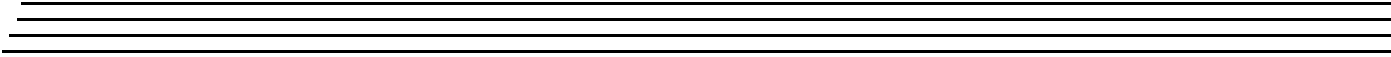

## Trademark and Copyright Information

Measurement Computing Corporation, InstaCal, Universal Library, and the Measurement Computing logo are either trademarks or registered trademarks of Measurement Computing Corporation. Refer to the Copyrights & Trademarks section on [mccdaq.com/legal](http://mccdaq.com/legal) for more information about Measurement Computing trademarks.

Other product and company names mentioned herein are trademarks or trade names of their respective companies.

© 2019 Measurement Computing Corporation. All rights reserved. No part of this publication may be reproduced, stored in a retrieval system, or transmitted, in any form by any means, electronic, mechanical, by photocopying, recording, or otherwise without the prior written permission of Measurement Computing Corporation.

### **Notice**

Measurement Computing Corporation does not authorize any Measurement Computing Corporation product for use in life support systems and/or devices without prior written consent from Measurement Computing Corporation. Life support devices/systems are devices or systems that, a) are intended for surgical implantation into the body, or b) support or sustain life and whose failure to perform can be reasonably expected to result in injury. Measurement Computing Corporation products are not designed with the components required, and are not subject to the testing required to ensure a level of reliability suitable for the treatment and diagnosis of people.

## Radio and Television Interference

This equipment has been tested and found to comply with CISPR EN55022 Class A and EN61000-6-1 requirements and also with the limits for a Class A digital device, pursuant to Part 15 of the FCC Rules. These limits are designed to provide reasonable protection against harmful interference when the equipment is operated in a commercial environment. This equipment generates, uses, and can radiate radio frequency energy and, if not installed and used in accordance with the instruction manual, may cause harmful interference to radio communications. Operation of this equipment in a residential area is likely to cause harmful interference, in which case the user will be required to correct the interference at his own expense.

Changes or modifications to this equipment not expressly approved by Data Translation could void your authority to operate the equipment under Part 15 of the FCC Rules.

---

**Note:** This product was verified to meet FCC requirements under test conditions that included use of shielded cables and connectors between system components. It is important that you use shielded cables and connectors to reduce the possibility of causing interference to radio, television, and other electronic devices.

---

## Canadian Department of Communications Statement

This digital apparatus does not exceed the Class A limits for radio noise emissions from digital apparatus set out in the Radio Interference Regulations of the Canadian Department of Communications.

Le présent appareil numérique n'émet pas de bruits radioélectriques dépassant les limites applicables aux appareils numériques de la class A prescrites dans le Règlement sur le brouillage radioélectrique édicté par le Ministère des Communications du Canada.



---

# Table of Contents

<b>About this Manual</b> .....	<b>9</b>
Intended Audience .....	9
How this Manual is Organized .....	9
Conventions Used in this Manual .....	10
Related Information .....	10
Where To Get Help .....	11
<b>Chapter 1: Overview</b> .....	<b>13</b>
DT9838 Hardware Features .....	14
Supported Software .....	16
Supported Accessories .....	19
Getting Started Procedure .....	22
<b>Chapter 2: Setting Up and Installing the Module</b> .....	<b>25</b>
Unpacking .....	27
System Requirements .....	28
(Optional) Applying Power to the Module .....	29
Attaching Modules to the Computer .....	31
Connecting Directly to the USB Ports .....	31
Connecting to an Expansion Hub .....	32
Configuring the DT9838 Device Driver .....	34
<b>Chapter 3: Wiring Signals</b> .....	<b>35</b>
Preparing to Wire Signals .....	37
General Wiring Recommendations .....	38
Definitions .....	38
Analog Input Connector Pin Assignments (RJ50 Connector) .....	39
Connecting a General-Purpose or Bridge-Completion Accessory .....	40
Connecting Quarter-Bridge Circuits .....	42
Wiring a Quarter-Bridge (Axial and Bending) Circuit .....	42
Remote Sensing In Quarter-Bridge Configurations .....	45
Shunt Calibration in Quarter-Bridge Configurations .....	46
Wiring a Quarter-Bridge Temp Comp Circuit .....	47
Remote Sensing In Quarter-Bridge Temp Comp Configurations .....	48
Shunt Calibration in Quarter-Bridge Temp Comp Configurations .....	49
Connecting Half-Bridge Circuits .....	50
Wiring a Half-Bridge Poisson Circuit .....	50
Remote Sensing In Half-Bridge Poisson Configurations .....	52
Shunt Calibration in Half-Bridge Poisson Configurations .....	53

Wiring a Half-Bridge Bending Circuit . . . . .	54
Remote Sensing In Half-Bridge Bending Configurations . . . . .	55
Shunt Calibration in Half-Bridge Bending Configurations . . . . .	56
Connecting Full-Bridge Circuits . . . . .	57
Wiring a Full-Bridge Bending Circuit . . . . .	57
Remote Sensing in Full-Bridge Bending Configurations . . . . .	59
Shunt Calibration in Full-Bridge Bending Configurations . . . . .	59
Wiring a Full-Bridge Bending Poisson Configuration. . . . .	60
Remote Sensing in Full-Bridge Bending Poisson Configurations . . . . .	61
Shunt Calibration in Full-Bridge Bending Poisson Configurations . . . . .	62
Wiring a Full-Bridge Axial Poisson Circuit. . . . .	63
Remote Sensing in Full-Bridge Axial Poisson Configurations . . . . .	64
Shunt Calibration in Full-Bridge Axial Poisson Configurations . . . . .	65
Connecting Load Cells and Other Transducers. . . . .	66
Connecting Voltage Inputs . . . . .	68
Connecting a Tachometer Input Signal. . . . .	69
Connecting an External Trigger Signal. . . . .	70
<b>Chapter 4: Verifying the Operation of a Module . . . . .</b>	<b>71</b>
Select the Device . . . . .	73
Measure Strain Gage Data . . . . .	76
Configure the Channels . . . . .	76
Configure the Recording Settings. . . . .	84
Configure the Acquisition Settings. . . . .	85
Start the Operation . . . . .	86
<b>Chapter 5: Principles of Operation . . . . .</b>	<b>89</b>
Analog Input Features . . . . .	91
Analog Input Channels . . . . .	91
Specifying a Single Analog Input Channel . . . . .	91
Specifying One or More Analog Input Channels . . . . .	91
Bridge Configurations . . . . .	92
Quarter-Bridge Configuration . . . . .	94
Quarter-Bridge Temp Comp Configuration . . . . .	95
Half-Bridge Poisson Configuration . . . . .	95
Half-Bridge Bending Configuration . . . . .	96
Full-Bridge Bending Circuit . . . . .	97
Full-Bridge Bending Poisson Configuration . . . . .	98
Full-Bridge Axial Poisson Configuration . . . . .	99
Transducer Support . . . . .	99
Bridge Excitation . . . . .	100
Remote Sensing and Lead Wire Correction . . . . .	100

Shunt Calibration .....	101
Shunt Calibration Equation for the Quarter-Bridge and Quarter-Bridge Temp Comp Configurations .....	102
Shunt Calibration Equation for the Half-Bridge Poisson Configuration .....	102
Shunt Calibration Equation for the Half-Bridge Bending Configuration .....	102
Shunt Calibration Equation for the Full-Bridge Bending Configuration .....	103
Shunt Calibration Equation for the Full-Bridge Bending Poisson Configuration .....	103
Shunt Calibration Equation for the Full-Bridge Axial Poisson Configuration ..	103
Offset Nulling .....	103
TEDS .....	103
Input Resolution .....	104
Input Range .....	104
A/D Sample Clock .....	104
Analog Input Conversion Modes .....	105
Single-Value Mode .....	105
Continuous Scan Mode .....	105
Input Triggers .....	107
Start Trigger Sources .....	107
Reference Trigger Sources .....	108
Data Format .....	109
Error Conditions .....	109
Tachometer Input Features .....	110
Synchronizing Acquisition on Multiple Modules .....	112
Triggering DT9838 and DT9837 Series Modules Using the Sync Bus .....	114
<b>Chapter 6: Supported Device Driver Capabilities .....</b>	<b>117</b>
Data Flow and Operation Options .....	119
Buffering .....	120
Triggered Scan Mode .....	120
Data Encoding .....	120
Channels .....	121
Gain .....	121
Ranges .....	122
Resolution .....	122
Current and Resistance Support .....	122
Thermocouple, RTD, and Thermistor Support .....	123
IEPE Support .....	124
Bridge and Strain Gage Support .....	124
Start Triggers .....	125
Reference Triggers .....	125
Clocks .....	126

Counter/Timers .....	127
Tachometers .....	128
<b>Chapter 7: Troubleshooting .....</b>	<b>129</b>
General Checklist .....	130
Technical Support .....	132
If Your Module Needs Factory Service .....	133
<b>Chapter 8: Calibration .....</b>	<b>135</b>
Using the Calibration Utility .....	136
Calibrating the Analog Input Subsystem .....	137
Connecting a Precision Voltage Source .....	137
Using the Auto-Calibration Procedure .....	137
Using the Manual Calibration Procedure .....	138
Calibrating the Internal Analog Output Circuitry (Excitation Voltage) .....	139
Connecting a Digital Voltmeter .....	139
Calibrating the Analog Output Circuitry .....	139
<b>Appendix A: Specifications .....</b>	<b>141</b>
Analog Input Specifications .....	142
Bridge Specifications .....	143
Tachometer Input Specifications .....	144
Trigger Specifications .....	145
Power, Physical, and Environmental Specifications .....	146
Regulatory Specifications .....	147
Connector Specifications .....	148
External Power Supply Specifications .....	149
<b>Appendix B: Connector Pin Assignments .....</b>	<b>151</b>
Analog Input Connectors .....	152
Sync Bus Connector .....	153
External Trigger and Tachometer Connector .....	154
External USB Connector .....	155
External Power Connector .....	156
Screw Terminals on the STP STRAIN, STP STRAIN 120, and STP STRAIN 350 .....	157
<b>Index .....</b>	<b>159</b>



# About this Manual

The first part of this manual describes how to install and set up your DT9838 module and device driver, and verify that your module is working properly.

The second part of this manual describes the features of the DT9838 module, the capabilities of the DT9838 Device Driver, and how to program the DT9838 module using DT-Open Layers for .NET Class Library™ software. Troubleshooting information is also provided.

---

**Notes:** For more information on the class library, refer to the *DT-Open Layers for .NET Class Library User's Manual*. If you are using the DataAcq SDK or a software application to program your device, refer to the documentation for that software for more information.

---

## Intended Audience

This document is intended for engineers, scientists, technicians, or others responsible for installing, setting up, using, and/or programming DT9838 modules for data acquisition operations.

It is assumed that you are familiar with the requirements of your application. It is also assumed that you have some familiarity with data acquisition principles, that you understand your application, and that you are familiar with the Microsoft® Windows Vista®, Windows 7, Windows 8, or Windows 10 operating system.

## How this Manual is Organized

This manual is organized as follows:

- [Chapter 1, "Overview,"](#) describes the major features of the DT9838 module, as well as the supported software and accessories for the modules.
- [Chapter 2, "Setting Up and Installing the Module,"](#) describes how to apply power to the module, how to attach the module to your computer, and how to configure the device driver.
- [Chapter 3, "Wiring Signals,"](#) describes how to wire signals to the DT9838 module.
- [Chapter 4, "Verifying the Operation of a Module,"](#) describes how to verify the operation of the module with the QuickDAQ application.
- [Chapter 5, "Principles of Operation,"](#) describes all of the features of the module and how to use them in your application.
- [Chapter 6, "Supported Device Driver Capabilities,"](#) lists the data acquisition subsystems and the associated features accessible using the DT9838 Device Driver.
- [Chapter 7, "Troubleshooting,"](#) provides information that you can use to resolve problems with the module and device driver, should they occur.

- [Chapter 8, “Calibration,”](#) describes how to calibrate the analog I/O circuitry of the module.
- [Appendix A, “Specifications,”](#) lists the specifications of the DT9838 module.
- [Appendix B, “Connector Pin Assignments,”](#) shows the pin assignments of the connectors on the DT9838 module.
- An index completes this manual.

## Conventions Used in this Manual

The following conventions are used in this manual:

- Notes provide useful information that requires special emphasis, cautions provide information to help you avoid losing data or damaging your equipment, and warnings provide information to help you avoid catastrophic damage to yourself or your equipment.
- Items that you select or type are shown in **bold**.
- Courier font is used to represent source code.

## Related Information

Refer to the following documents for more information on using the DT9838 module:

- *QuickDAQ User's Manual* (UM-24774). This manual describes how to create a QuickDAQ application to acquire and analyze data from DT-Open Layers data acquisition devices.
- *DT-Open Layers for .NET User's Manual* (UM-22161). For programmers who are developing their own application programs using Visual C# or Visual Basic .NET, this manual describes how to use the DT-Open Layers for .NET Class Library to access the capabilities of Data Translation data acquisition devices.
- *DataAcq SDK User's Manual* (UM-18326). For programmers who are developing their own application programs using the Microsoft C compiler, this manual describes how to use the DT-Open Layers™ DataAcq SDK™ to access the capabilities of Data Translation data acquisition devices.
- *LV-Link Online Help*. This help file describes how to use LV-Link™ with the LabVIEW™ graphical programming language to access the capabilities of Data Translation data acquisition devices.
- *DAQ Adaptor for MATLAB* (UM-22024). This document describes how to use Data Translation's DAQ Adaptor to provide an interface between the MATLAB Data Acquisition subsystem from The MathWorks and Data Translation's DT-Open Layers architecture.
- Microsoft Windows Vista, Windows 7, Windows 8, or Windows 10 documentation.
- USB web site (<http://www.usb.org>)

## **Where To Get Help**

Should you run into problems installing or using a DT9838 module, the Technical Support Department is available to provide technical assistance. Refer to [Chapter 7](#) starting on [page 129](#) for information. If you are outside the United States or Canada, call your local distributor, whose number is listed on our web site [www.mccdaq.com](http://www.mccdaq.com).





# ***Overview***

DT9838 Hardware Features .....	14
Supported Software .....	16
Supported Accessories .....	19
Getting Started Procedure .....	22

## DT9838 Hardware Features

The DT9838 module, shown in [Figure 1](#), is a USB strain gage measurement device intended for full-, half-, and quarter-bridge strain gage elements and bridge-based sensor assemblies such as load cells, torque sensors, and pressure sensors, as well as general-purpose voltage measurements. It is compatible with USB 2.0 and USB 1.1 ports.

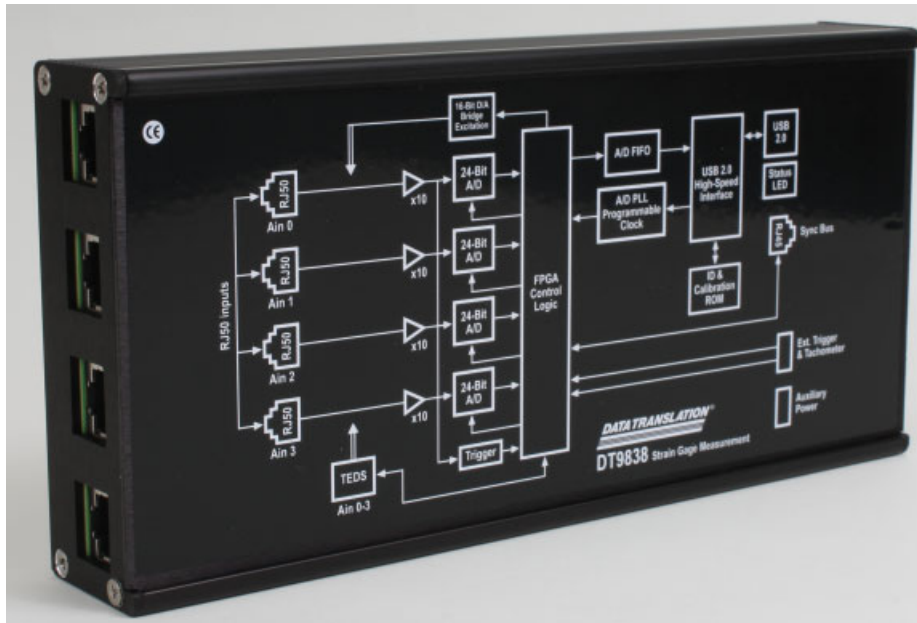

**Figure 1: DT9838 Module**

The key hardware features of the DT9838 are as follows:

- Simultaneous measurement of four 24-bit analog input channels and one tachometer in the analog input stream
- Direct full-bridge and half-bridge support with half-bridge completion
- Quarter-bridge support with external bridge-completion resistor
- Load cell support
- Non-bridged voltage input configuration
- Programmable input and bridge configuration
- Internal bridge excitation of 0 to 10 V in 167  $\mu$ V steps
- Programmable 100 k $\Omega$   $\pm$ 0.1% shunt resistor per channel
- TEDS (IEEE 1451.4) sensor compatible
- Software calibration of the bridge offset and gain
- Sampling frequency from 195.3125 Hz to 52.734 kHz
- Input range of  $\pm$ 250 mV

- Continuously paced analog input operations
- Software-programmable trigger type (software, external digital trigger, or variable digital threshold trigger) to start analog input operations
- Sync Bus (RJ45) connector for synchronizing acquisition on up to four DT9838 modules
- LEDs for monitoring the arm/trigger state and USB status

---

**Note:** A board-level version of this module (without the enclosure) is also available for OEM applications.

---

## Supported Software

The DT Omni installer includes the following software for use with the DT9838 module:

- **DT9838 Device Driver** – The DT9838 Device Driver allows you to use a DT9838 module with any of the supported software packages or utilities.
- **QuickDAQ Base Version** – The base version of QuickDAQ is free-of-charge and allows you to acquire and analyze data from all Data Translation USB and Ethernet devices, except the DT9841 Series, DT9817, DT9835, and DT9853/54. Using the base version of QuickDAQ, you can perform the following functions:
  - Discover and select your devices.
  - Configure all input channel settings for the attached sensors.
  - Load/save multiple hardware configurations.
  - Generate output stimuli (fixed waveforms, swept sine waves, or noise signals).
  - On each supported data acquisition device, acquire data from all channels supported in the input channel list.
  - Choose to acquire data continuously or for a specified duration.
  - Choose software or triggered acquisition.
  - Log acquired data to disk in an .hpf file.
  - Display acquired data during acquisition in either a digital display using the Channel Display window or as a waveform in the Channel Plot window.
  - Choose linear or logarithmic scaling for the horizontal and vertical axes.
  - View statistics about the acquired data, including the minimum, maximum, and mean values and the standard deviation in the Statistics window.
  - Export time data to a .csv or .txt file; you can open the recorded data in Microsoft Excel® for further analysis.
  - Read a previously recorded .hpf data file.
  - Customize many aspects of the acquisition, display, and recording functions to suit your needs, including the acquisition duration, sampling frequency, trigger settings, filter type, and temperature units to use.
- **QuickDAQ FFT Analysis Option** – When enabled with a purchased license key, the QuickDAQ FFT Analysis option includes all the features of the QuickDAQ Base version plus basic FFT analysis features, including the following:
  - The ability to switch between the Data Logger time-based interface and the FFT Analyzer block/average-based interface.
  - Supports software, freerun, or triggered acquisition with accept and reject controls for impact testing applications.
  - Allows you to perform single-channel FFT (Fast Fourier Transform) operations, including AutoSpectrum, Spectrum, and Power Spectral Density, on the acquired analog input data. You can configure a number of parameters for the FFT, including the FFT size, windowing type, averaging type, integration type, and so on.
  - Allows you to display frequency-domain data as amplitude or phase.



- Supports dB or linear scaling with RMS (root mean squared), peak, and peak-to-peak scaling options
- Supports linear or exponential averaging with RMS, vector, and peak hold averaging options.
- Supports windowed time channels.
- Supports the following response window types: Hanning, Hamming, Bartlett, Blackman, Blackman Harris, and Flat top.
- Supports the ability to lock the waveform output to the analysis frame time.
- Allows you to configure and view dynamic performance statistics, including the input below full-scale (IBF), total harmonic distortion (THD), spurious free dynamic range (SFDR), signal-to-noise and distortion ratio (SINAD), signal-to-noise ratio (SNR), and the effective number of bits (ENOB), for selected time-domain channels in the Statistics window.
- Supports digital IIR (infinite impulse response) filters.
- **QuickDAQ Advanced FFT Analysis Option** – When enabled with a purchased software license, the QuickDAQ Advanced FFT Analysis option includes all the features of the QuickDAQ Base version with the FFT Analysis option plus advanced FFT analysis features, including the following:
  - Allows you to designate a channel as a Reference or Response channel.
  - Allows you to perform two-channel FFT analysis functions, including Frequency Response Functions (Inertance, Mobility, Compliance, Apparent Mass, Impedance, Dynamic Stiffness, or custom FRF) with H1, H2, or H3 estimator types, Cross-Spectrum, Cross Power Spectral Density, Coherence, and Coherent Output Power.
  - Supports the Exponential response window type.
  - Supports the following reference window types: Hanning, Hamming, Bartlett, Blackman, Blackman Harris, FlatTop, Exponential, Force, and Cosine Taper windows.
  - Supports real, imaginary, and Nyquist display functions.
  - Allows you to save data in the .uff file format.
- **DT-Open Layers for .NET Class Library** – Use this class library if you want to use Visual C# or Visual Basic for .NET to develop your own application software for a DT9838 module using Visual Studio 2003 to 2012; the class library complies with the DT-Open Layers standard.
- **DataAcq SDK** – Use the Data Acq SDK if you want to use Visual Studio 6.0 and Microsoft C or C++ to develop your own application software for a DT9838 module using Windows Vista, Windows 7, or Windows 8; the DataAcq SDK complies with the DT-Open Layers standard.
- **DAQ Adaptor for MATLAB** – A link to the DAQ Adaptor for MATLAB is included from the DT Omni installer. Data Translation's DAQ Adaptor provides an interface between the MATLAB Data Acquisition (DAQ) subsystem from The MathWorks and Data Translation's DT-Open Layers architecture.

- **LV-Link** – A link to LV-Link is included from the DT Omni installer. Use LV-Link if you want to use the LabVIEW graphical programming language to access the capabilities of the DT9838 module.

Refer to the web site [www.mccdaq.com](http://www.mccdaq.com) for information about selecting the right software package for your needs.

# Supported Accessories

The following accessories are available for the DT9838 module:

- **STP STRAIN General-Purpose Accessory** – This accessory contains four general-purpose screw terminal panels. Use one screw terminal panel for each channel.



Figure 2: STP STRAIN General-Purpose Accessory

- **STP STRAIN 120 Quarter-Bridge Completion Accessory** – This accessory contains four screw terminal panels with a 120 Ω quarter-bridge completion resistor installed on each screw terminal panel. Use one screw terminal panel for each channel.

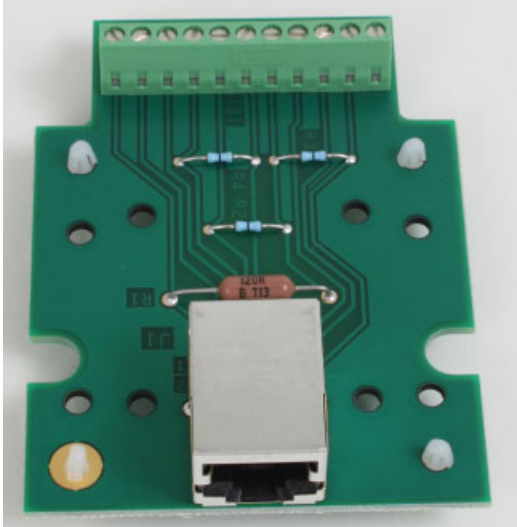
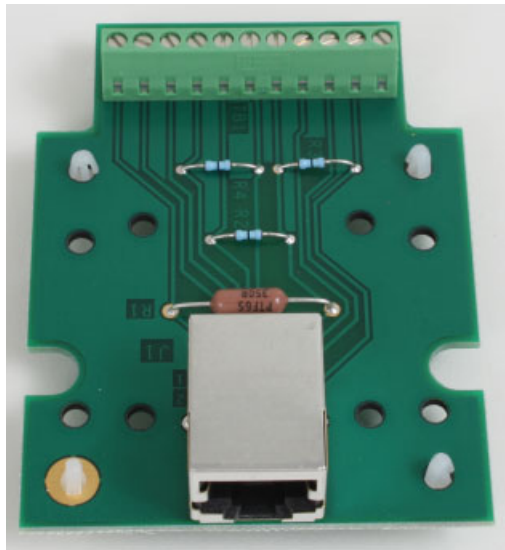

Figure 3: STP STRAIN 120 Quarter-Bridge Completion Accessory

- **STP STRAIN 350 Quarter-Bridge Completion Accessory** – This accessory contains four screw terminal panels with a 350  $\Omega$  quarter-bridge completion resistor installed on each screw terminal panel. Use one screw terminal panel for each channel.



**Figure 4: STP STRAIN 350 Quarter-Bridge Completion Accessory**

- **EP398 RJ50 cables** – The EP398 accessory contains four RJ50 cables that are used to connect four STP STRAIN, STP STRAIN 120, or STP STRAIN 350 screw terminal panels to the DT9838 module. [Figure 5](#) shows an RJ50 cable.



**Figure 5: RJ50 Cable**

- **EP394 +5 V external power supply** – Use this optional power supply, shown in [Figure 6](#), if you want to use an external +5 V power supply to power the DT9838 module. Refer to [page 29](#) for information on using internal USB power or external +5 V power to power the DT9838 module.



**Figure 6: EP394 External +5 V Power Supply**

- **EP386 panel** – The EP386 panel, shown in [Figure 7](#), contains four RJ45 connectors that are wired in parallel, making it useful when attaching up to four DT9838 modules together using the Sync Bus. Refer to [page 112](#) for more information on using this panel.

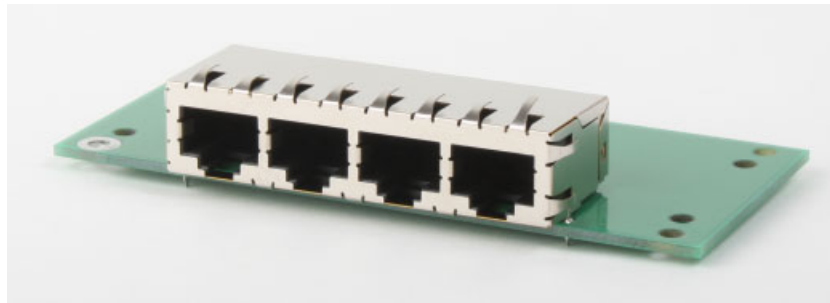

**Figure 7: EP386 Panel**

## Getting Started Procedure

The flow diagram shown in [Figure 8](#) illustrates the steps needed to get started using the DT9838 module. This diagram is repeated in each Getting Started chapter; the shaded area in the diagram shows you where you are in the procedure.

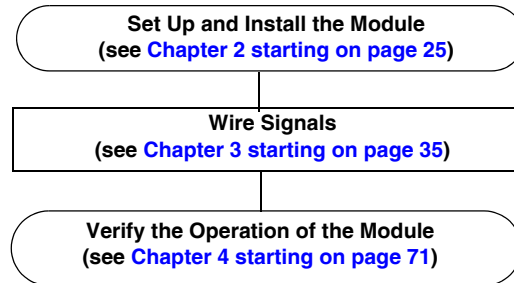

**Figure 8: Getting Started Flow Diagram**

# ***Part 1: Getting Started***







## ***Setting Up and Installing the Module***

Unpacking .....	27
System Requirements .....	28
(Optional) Applying Power to the Module .....	29
Attaching Modules to the Computer .....	31
Configuring the DT9838 Device Driver .....	34

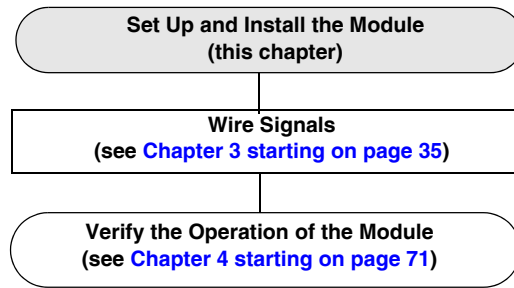

---

**Note:** The DT9838 module is factory-calibrated. If you decide that you want to recalibrate the analog input circuitry, refer to the instructions on [Chapter 8](#).

---

## ***Unpacking***

Open the shipping box and verify that the DT9838 module is missing and undamaged.

If the module is damaged, contact Data Translation. If you are in the United States, call the Customer Service Department at (508) 956-5100. An application engineer will guide you through the appropriate steps for replacing damaged items. If you are located outside the United States, call your local distributor (see [www.mccdaq.com](http://www.mccdaq.com) for more information).

## ***System Requirements***

For reliable operation, ensure that your computer meets the following system requirements:

- Processor: Pentium 4/M or equivalent
- RAM: 1 GB
- Screen Resolution: 1024 x 768 pixels
- Operating System: Windows 10, Windows 8, Windows 7, or Windows Vista (32- and 64-bit)
- Disk Space: 4 GB

## (Optional) Applying Power to the Module

The DT9838 is designed to operate from USB power alone. However, the number of channels that it can power is limited by the USB port power capability, the programmed excitation voltage, and the bridge resistance. To enhance the bridge drive capability, you can purchase the optional +5 V power supply (model number EP394) available from Data Translation or use an external +5 to +24 VDC power supply to power the DT9838 module.

Table 1 shows the number of channels that are supported when the module is powered with USB power or external power, given different bridge configurations and excitation voltages.

**Table 1: Number of Channels Supported when Module is Powered with USB Power or External Power**

Bridge Configuration	Excitation Voltage	USB Power Supplied			5 V to 24 V External Power Supplied		
		Bridge Resistance			Bridge Resistance		
		120 $\Omega$	350 $\Omega$	1 k $\Omega$	120 $\Omega$	350 $\Omega$	1 k $\Omega$
Full Bridge	2.5 V	3 channels	4 channels	4 channels	4 channels	4 channels	4 channels
	3.3 V	2 channels	4 channels	4 channels	4 channels	4 channels	4 channels
	5 V	–	4 channels	4 channels	–	4 channels	4 channels
	10 V	–	1 channel	3 channels	–	4 channels	4 channels
Quarter Bridge and Half Bridge	2.5 V	4 channels	4 channels	4 channels	4 channels	4 channels	4 channels
	3.3 V	4 channels	4 channels	4 channels	4 channels	4 channels	4 channels
	5 V	3 channels	4 channels	4 channels	4 channels	4 channels	4 channels
	10 V	–	2 channel	4 channels	–	4 channels	4 channels

To attach an external power supply to the module, do the following:

1. Connect the +5 V power supply (EP394) to the auxiliary power connector on the DT9838 module, as shown in [Figure 9](#).
2. Plug the power supply into a wall outlet.

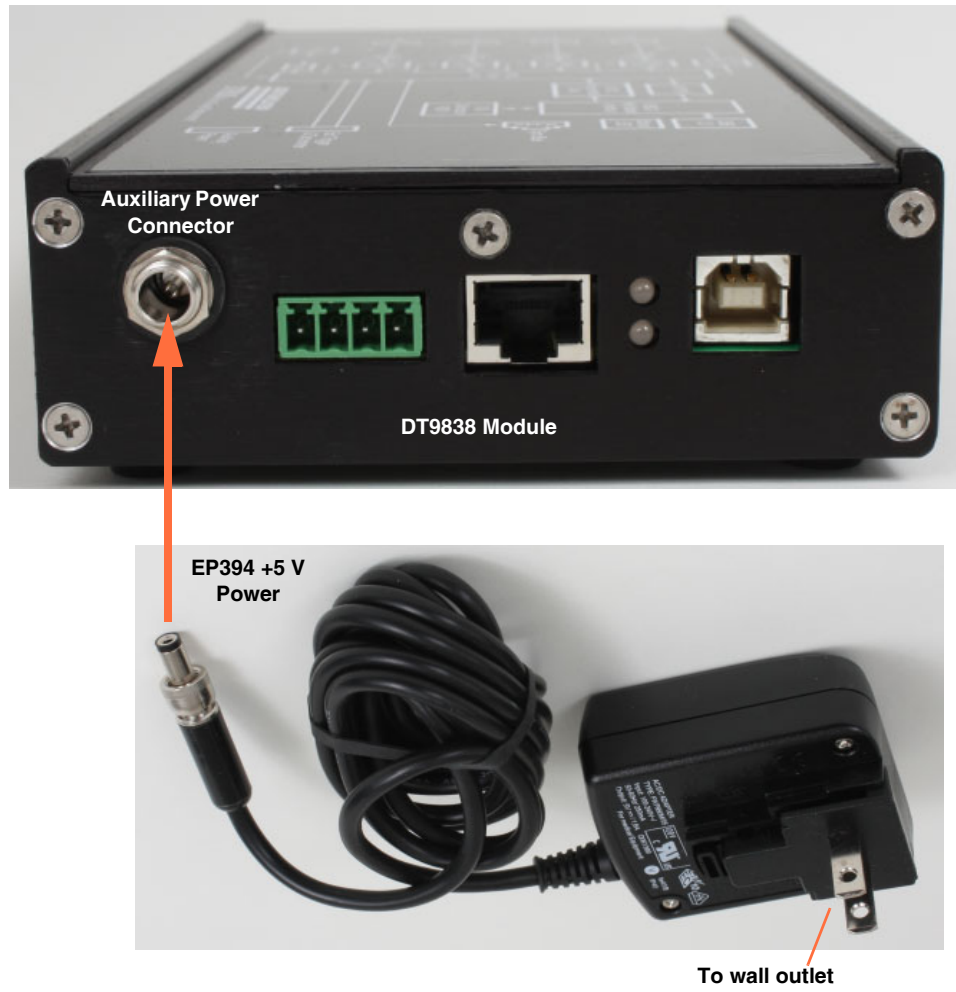

**Figure 9: Attaching an External +5 V Power Supply to the DT9838 Module**

## Attaching Modules to the Computer

This section describes how to attach DT9838 modules to the host computer.

---

**Note:** Most computers have several USB ports that allow direct connection to USB devices. If your application requires more DT9838 modules than you have USB ports for, you can expand the number of USB devices attached to a single USB port by using expansion hubs. For more information, refer to [page 32](#).

You can unplug a module, then plug it in again, if you wish, without causing damage. This process is called hot-swapping. Your application may take a few seconds to recognize a module once it is plugged back in.

---

You must install the device driver before connecting your DT9838 module(s) to the host computer. Run the DT Omni software to install the device driver and other software for the module.

### Connecting Directly to the USB Ports

To connect a DT9838 module directly to a USB port on your computer, do the following:

1. Attach one end of the USB cable to the USB port on the module.
2. Attach the other end of the USB cable to one of the USB ports on the host computer, as shown in [Figure 10](#).

*The operating system automatically detects the USB module and starts the Found New Hardware wizard.*



Connect the USB cable to the DT9838 module and to your computer.

**Figure 10: Attaching the DT9838 Module to the Host Computer**

3. For Windows Vista:
  - a. Click **Locate and install driver software (recommended)**.  
*The popup message "Windows needs your permission to continue" appears.*
  - b. Click **Continue**.  
*The Windows Security dialog box appears.*
  - c. Click **Install this driver software anyway**.  
*The USB LED on the module turns green.*

---

**Note:** Windows 7, Windows 8, and Windows 10 find the device automatically.

---

4. Repeat these steps to attach another DT9838 module to the host computer, if desired.

## Connecting to an Expansion Hub

Expansion hubs are powered by their own external power supply. The practical number of DT9838 modules that you can connect to a single USB port depends on the throughput you want to achieve.

To connect multiple DT9838 modules to an expansion hub, do the following:

1. Attach one end of the USB cable to the module and the other end of the USB cable to an expansion hub.
2. Connect the power supply for the expansion hub to an external power supply.
3. Connect the expansion hub to the USB port on the host computer using another USB cable.  
*The operating system automatically detects the USB module and starts the Found New Hardware wizard.*
4. For Windows Vista:
  - a. Click **Locate and install driver software (recommended)**.  
*The popup message "Windows needs your permission to continue" appears.*
  - b. Click **Continue**.  
*The Windows Security dialog box appears.*
  - c. Click **Install this driver software anyway**.  
*The USB LED on the module turns green.*

---

**Note:** Windows 7, Windows 8, and Windows 10 find the device automatically.

---

5. Repeat these steps until you have attached the number of expansion hubs and modules that you require. Refer to [Figure 11](#).  
*The operating system automatically detects the USB devices as they are installed.*



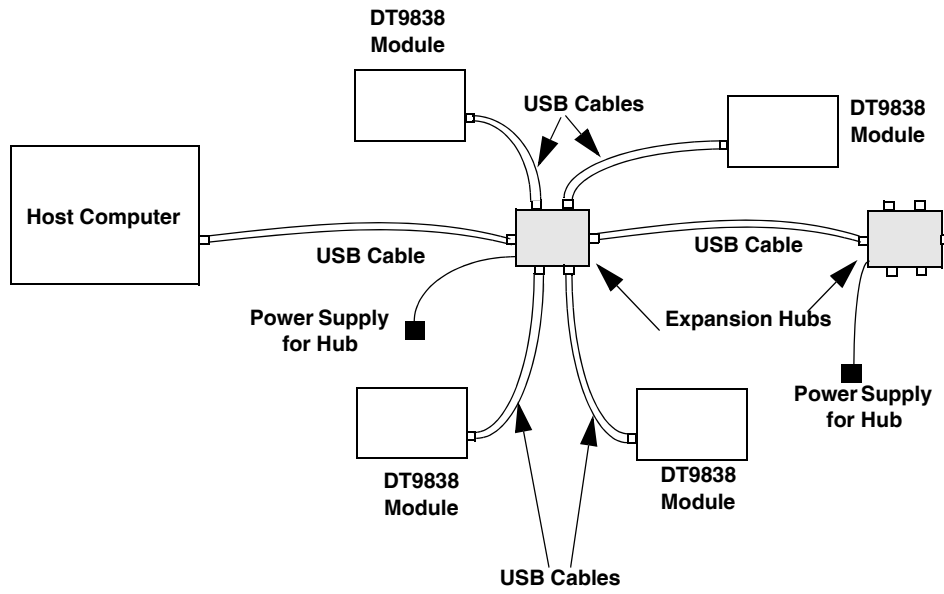

Figure 11: Attaching Multiple Modules Using Expansion Hubs

## Configuring the DT9838 Device Driver

---

**Note:** In Windows, you must have administrator privileges to run the Open Layers Control Panel. When you double-click the Open Layers Control Panel icon, you may see the Program Compatibility Assistant. If you do, select **Open the control panel using recommended settings**. You may also see a Windows message asking you if you want to run the Open Layers Control Panel as a "legacy CPL elevated." If you get this message, click **Yes**.

If you do not get this message and have trouble making changes in the Open Layers Control Panel, right click the DTOLCPL.CPL file and select **Run as administrator**. By default, this file is installed in the following location:

Windows (32-bit)

C:\Windows\System32\Dtolcpl.cpl

Windows (64-bit)

C:\Windows\SysWOW64\Dtolcpl.cpl

---

To configure the device driver for the DT9838 module, do the following:

1. If you have not already done so, power up the host computer and all peripherals.
2. From the Windows Start menu, select **Settings | Control Panel**.
3. From the Control Panel, double-click **Open Layers Control Panel**.  
*The Data Acquisition Control Panel dialog box appears.*
4. If you want to rename the module, click the name of the module that you want to rename, click **Edit Name**, enter a new name for the module, and then click **OK**. The name is used to identify the module in all subsequent applications.
5. Repeat step 4 for the other modules that you want to configure.
6. When you are finished configuring the modules, click **Close** to close the Control Panel.



## ***Wiring Signals***

Preparing to Wire Signals .....	37
Connecting a General-Purpose or Bridge-Completion Accessory .....	40
Connecting Quarter-Bridge Circuits .....	42
Connecting Half-Bridge Circuits .....	50
Connecting Full-Bridge Circuits .....	57
Connecting Load Cells and Other Transducers.....	66
Connecting Voltage Inputs .....	68
Connecting a Tachometer Input Signal.....	69
Connecting an External Trigger Signal.....	70

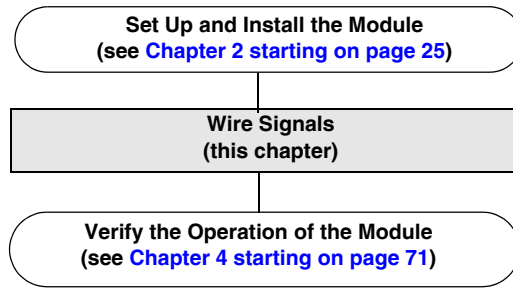

## Preparing to Wire Signals

Figure 12 shows the connectors of the DT9838 module. The left side of the DT9838 module contains four analog input (RJ50) connectors for connecting strain gages, load cells and other sensors, and/or voltage input signal. The right side of the DT9838 module provides the following connectors:

- Auxiliary power connector – Allows you to attach the optional EP394 external power supply.
- External trigger and tachometer connector – Provides screw terminals for connecting an external trigger and/or tachometer input signal.
- Sync Bus connector – Allows you to attach multiple modules together.
- USB connector – Allows you to attach the DT9838 module to your computer.



Figure 12: Connectors on the DT9838 Module (Side Views)

## General Wiring Recommendations

Keep the following recommendations in mind when wiring signals to the DT9838 module:

- Follow standard ESD procedures when wiring signals to the module.
- Separate power and signal lines by using physically different wiring paths or conduits.
- To avoid noise, do not locate the DT9838 module and cabling next to sources that produce high electromagnetic fields, such as large electric motors, power lines, solenoids, and electric arcs, unless the signals are enclosed in a mumetal shield.
- Prevent electrostatic discharge to the I/O while the DT9838 module is operational.
- Use an overall shielded cable for connections between the strain gages and the DT9838, with the shield connected to the chassis ground connection of the DT9838. A shield connection point is provided on pin 11 of the STP STRAIN, STP STRAIN 120, and STP STRAIN 350 accessories.
- Use individually shielded twisted-pair wire (size 14 to 26 AWG) when wiring voltage input signals to the DT9838 module.

## Definitions

The following terms are used in this chapter:

- $\varepsilon$  is the measured strain (+ $\varepsilon$  is the tensile strain and  $-\varepsilon$  is the compressive strain)
- $\nu$  is the Poisson's ratio, defined as the negative ratio of transverse strain to axial (longitudinal) strain
- $R_L$  is the lead resistance
- $R_g$  is the nominal gage resistance, which is specified by the gage manufacturer

## Analog Input Connector Pin Assignments (RJ50 Connector)

For analog input channels 0 to 3, the DT9838 module provides RJ50 connectors, shown in [Figure 13](#), for connecting strain gages, load-cell sensors, and/or voltage inputs. [Table 2](#) lists the pin assignments for the RJ50 connectors.

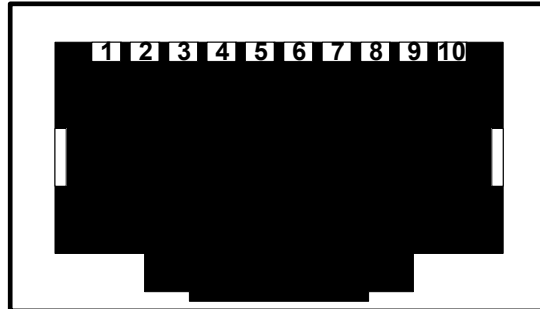

Figure 13: Analog Input (RJ50) Connector

Table 2: Pin Assignments for the RJ50 Connectors

Pin	Signal Description
1	RSHUNT+
2	AIN+
3	AIN-
4	SENSE+
5	SENSE-
6	EXC+
7	EXC-
8	TEDS DATA
9	TEDS RETURN
10	RSHUNT -

## Connecting a General-Purpose or Bridge-Completion Accessory

To make wiring bridges easier, you may want to purchase one of the following optional accessories:

- **STP STRAIN General-Purpose Accessory** – This accessory contains four general-purpose screw terminal panels. Use one screw terminal panel for each channel.
- **STP STRAIN 120 Quarter-Bridge Completion Accessory** – This accessory contains four screw terminal panels with a 120  $\Omega$  quarter-bridge completion resistor installed on each screw terminal panel. Use one screw terminal panel for each channel.
- **STP STRAIN 350 Quarter-Bridge Completion Accessory** – This accessory contains four screw terminal panels with a 350  $\Omega$  quarter-bridge completion resistor installed on each screw terminal panel. Use one screw terminal panel for each channel.

Figure 14 shows the layout of the STP STRAIN, STP STRAIN 120, and STP STRAIN 350 accessories.

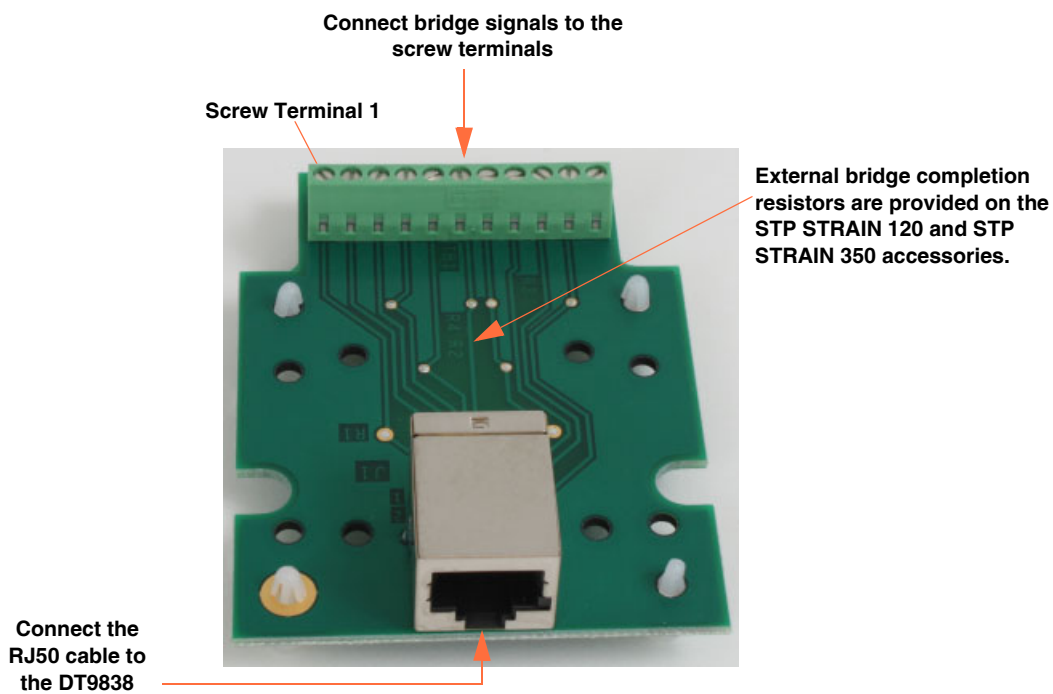

Figure 14: Layout of the STP STRAIN, STP STRAIN 120, and STP STRAIN 350 Accessories

The screw terminal assignments of the STP STRAIN, STP STRAIN 120, and STP STRAIN 350 screw terminal panels, listed in Table 3, match the pin designations of the RJ45 analog input connectors on the DT9838.



**Table 3: Pin Assignments for the STP STRAIN, STP STRAIN 120, and STP STRAIN 350 Screw Terminal Panels**

Pin	Signal Description
1	Shunt Cal+
2	Input+
3	Input-
4	Sense+
5	Sense-
6	Excitation+
7	Excitation-
8	TEDS+ (Data)
9	TEDS- (Return)
10	Shunt Cal-
11	Shield

The optional EP398 contains four RJ50 cables. Use an RJ50 cable to connect the RJ50 connector on the STP STRAIN, STP STRAIN 120, or STP STRAIN 350 screw terminal panel to the RJ50 connector on the DT9838 module, as shown in [Figure 15](#).

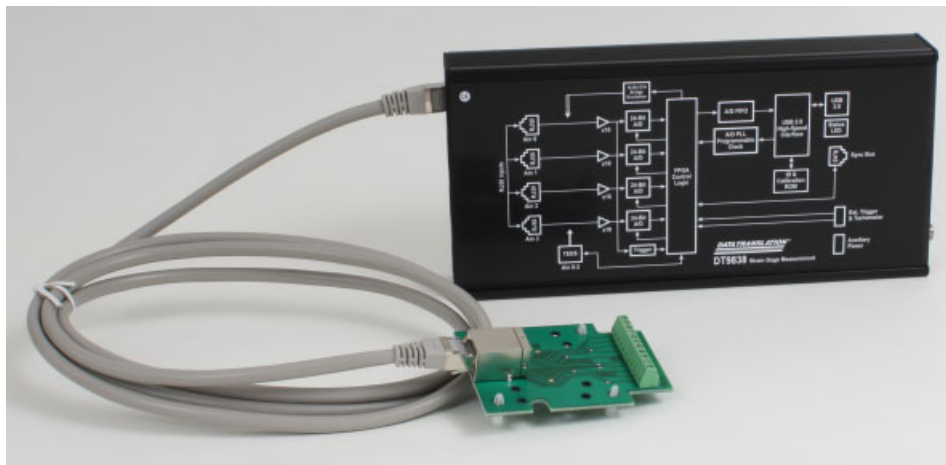

**Figure 15: Connecting the STP STRAIN, STP STRAIN 120, or STP STRAIN 350 Accessory to the DT9838 Module**

## Connecting Quarter-Bridge Circuits

The DT9838 module supports the following quarter-bridge configurations:

- Quarter-Bridge (Axial and Bending)
- Quarter-Bridge Temp Comp

This section describes how to wire the Quarter-Bridge and Quarter-Bridge Temp Comp circuits to the DT9838 module. For more information about these bridge configuration types, refer to [page 94](#).

### Wiring a Quarter-Bridge (Axial and Bending) Circuit

The Quarter-Bridge configuration, shown in [Figure 16](#), measures axial or bending strain.

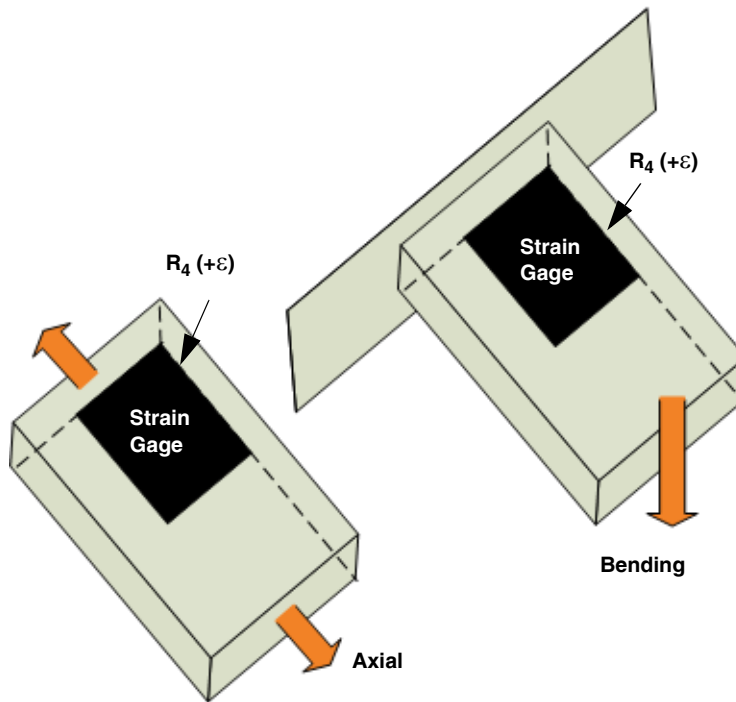

**Figure 16: Quarter-Bridge Configuration**

The Quarter-Bridge configuration has the following characteristics:

- A single active strain gage element is mounted in the direction of axial or bending strain.
- You must supply a resistor ( $R_3$ ) that matches the nominal resistance of the bridge to complete the bridge externally. This is supplied for you when you use the STP STRAIN 120 or STP STRAIN 350 quarter-bridge completion accessory.

**Note:** In some cases, you may wish to use a rosette, which is arrangement of two or three closely positioned strain gage grids that are oriented to measure the normal strains along different directions in the underlying surface of a test material. The DT9838 supports rectangular and delta rosettes; tee rosettes are not supported.

A rectangular rosette is an arrangement of three strain gage grids where the second grid is angularly displaced from the first grid by 45 degrees and the third grid is angularly displaced from the first grid by 90 degrees. A delta rosette is an arrangement of three strain gage grids where the second grid is angularly displaced from the first grid by 60 degrees and the third grid is angularly displaced from the first grid by 120 degrees.

To use a rectangular or delta rosette, use the Quarter-Bridge configuration with the proper bridge completion. You can then read the strain value from each analog input channel individually, and if desired, use software to calculate the minimum and maximum principal strain values and their associated angles (in degrees).

---

[Figure 17](#) shows how to connect a 3-wire Quarter-Bridge circuit to the STP STRAIN 120 or STP STRAIN 350 quarter-bridge completion accessory. Remote sense lines (SENSE+ and SENSE-) are not used in the 3-wire connection scheme using the STP STRAIN 120 or STP STRAIN 350 quarter-bridge completion accessories; therefore, the remote sense lines are connected to the excitation lines (SENSE+ is connected to EXC+ and SENSE- is connected to EXC-) to ensure proper bridge voltage regulation. If the lead wire resistance is known, you can enter the lead wire correction coefficient in software. Refer to [page 100](#) for more information.

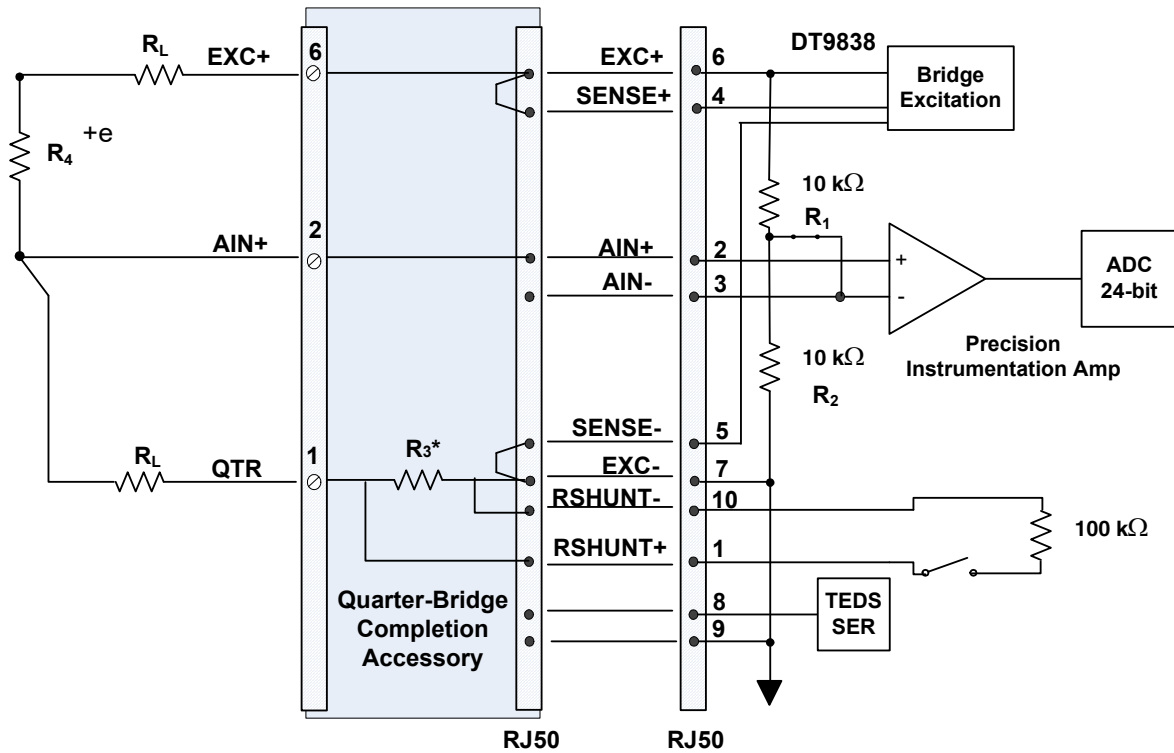

\*With the STP STRAIN 120 quarter-bridge completion accessory, the value of resistor  $R_3$  is  $120\ \Omega$  to match the value of resistor  $R_4$ .

With the STP STRAIN 350 quarter-bridge completion accessory, the value of resistor  $R_3$  is  $350\ \Omega$  to match the value of resistor  $R_4$ .

**Figure 17: Connecting a Quarter-Bridge Circuit to the DT9838 When Using the STP STRAIN 120 or STP STRAIN 350 Quarter-Bridge Completion Accessory**

Figure 18 shows how to connect a Quarter Bridge circuit to the DT9838 when using the general-purpose STP STRAIN accessory. In this example, the user-supplied resistor is mounted at the strain gage and the remote sense lines (SENSE+ and SENSE-) are not used; therefore, the remote sense lines are connected to the excitation lines (SENSE+ is connected to EXC+ and SENSE- is connected to EXC-) to ensure proper bridge voltage regulation. If the lead wire resistance is known, you can enter the lead wire correction coefficient in software. Refer to [page 100](#) for more information.

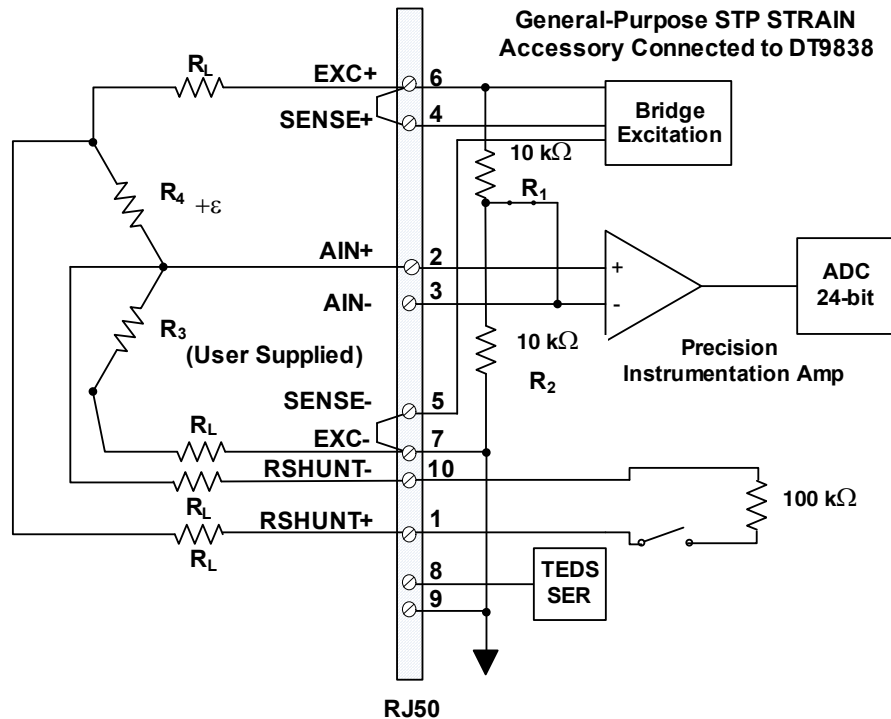

**Figure 18: Connecting a Quarter-Bridge Circuit to the DT9838 and General-Purpose STP STRAIN Accessory when the Completion Resistor is Mounted at the Strain Gage**

### Remote Sensing In Quarter-Bridge Configurations

Remote sensing is not used in the 3-wire Quarter-Bridge configurations that use the STP STRAIN 120 and STP STRAIN 350 quarter-bridge completion accessories, as shown in [Figure 17](#). However, you may want to use the remote sense lines (SENSE+ and SENSE-) in some applications that use Quarter-Bridge configurations, particularly where long wires and/or small gauge wires are used, to minimize voltage drops caused by the lead wire resistance of the EXC+ and EXC- lines.

[Figure 19](#) shows how to connect a Quarter Bridge circuit to the DT9838 using remote sense lines. In this example, the general-purpose STP STRAIN accessory is used and the user-supplied resistor is mounted at the strain gage.

---

**Note:** When remote sensing is used, enter 0  $\Omega$  for the lead wire correction coefficient in software. Refer to [page 100](#) for more information.

---

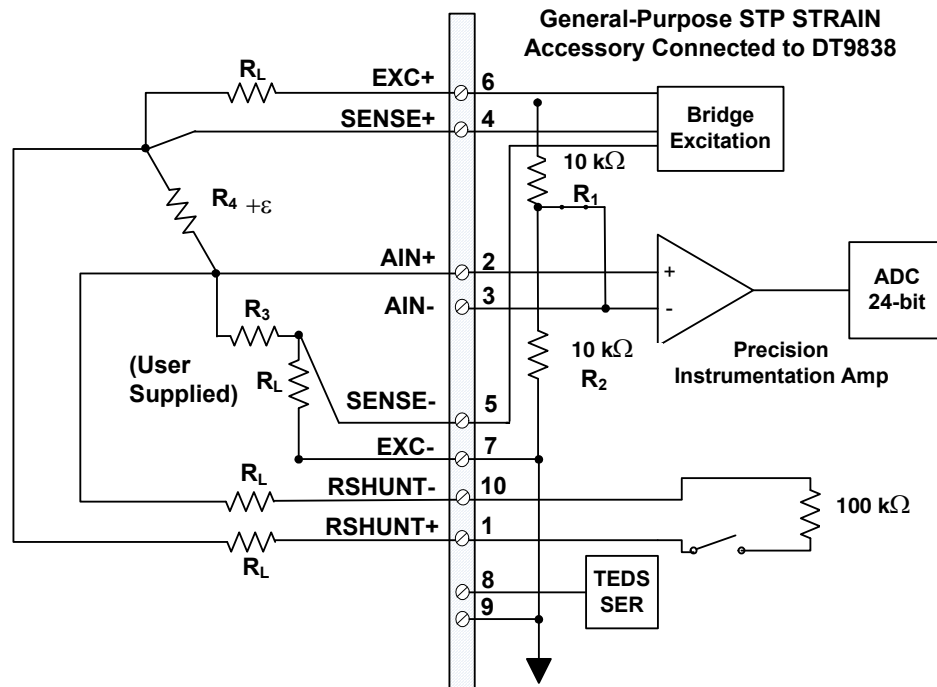

**Figure 19: Connecting a Quarter-Bridge Circuit to the DT9838 and General-Purpose STP STRAIN Accessory when the Completion Resistor is Mounted at the Strain Gage and the Remote Sense Lines are Used**

### Shunt Calibration in Quarter-Bridge Configurations

When setting up your strain gage, you can use shunt calibration to correct for errors due to lead wire resistance ( $R_L$ ) in the excitation wiring. Refer to [page 102](#) for the equations used for shunt calibration in Quarter-Bridge configurations.

To perform shunt calibration in a Quarter-Bridge configuration, the RSHUNT+ and RSHUNT- lines for the internal 100 kΩ shunt resistor are connected either across  $R_3$  or  $R_4$  of the connected bridge. However, when using the STP STRAIN 120 or STP STRAIN 350 bridge completion accessory, as shown in [Figure 17](#), the shunt resistor can only be connected across  $R_3$ . [Figure 18](#) and [Figure 19](#) show how to connect the RSHUNT+ and RSHUNT- lines when using the general-purpose STP STRAIN accessory.

In either case, while the bridge is in the unstrained condition, you can use software to switch in the shunt calibration resistor to simulate a known amount of strain. The measured output value with the shunt resistor in place is then compared to the expected value of strain with the shunt resistor in place. The gain of the bridge transfer function is then modified by the ratio of the expected strain to the measured strain, calibrating the system. Refer to your software documentation for more information about shunt calibration

Once you have verified your setup, you can disconnect the RSHUNT+ and RSHUNT- lines, if desired.

## Wiring a Quarter-Bridge Temp Comp Circuit

The Quarter-Bridge Temp Comp configuration, shown in [Figure 20](#), measures axial and bending strain and compensates for temperature.

---

**Note:** This configuration is often confused with the more commonly used Half-Bridge Poisson configuration, described on [page 50](#). In the Half-Bridge Poisson configuration, the  $R_3$  element is active and is bonded to the strain specimen to measure the effect of the Poisson ratio. In the Quarter-Bridge Temp Comp configuration,  $R_3$  is not active (a dummy strain gage is used) and is not bonded to the specimen.

---

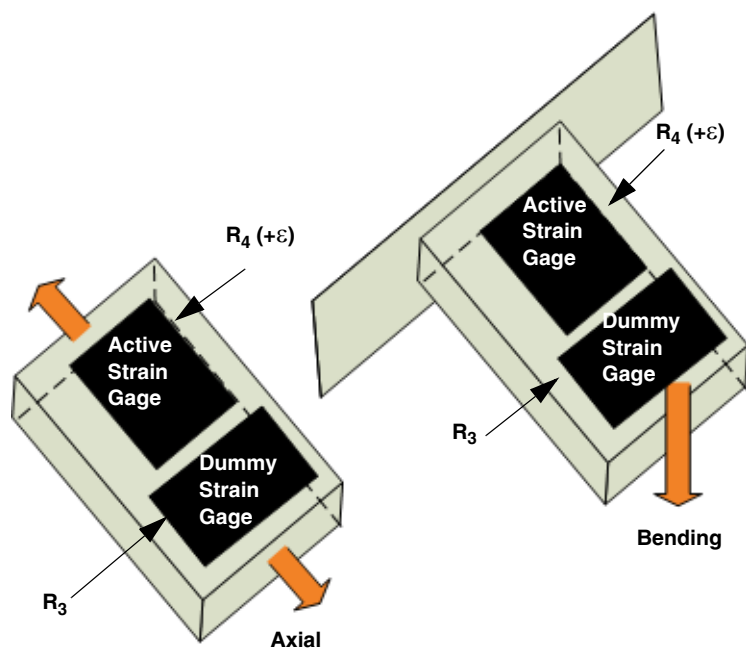

**Figure 20: Quarter-Bridge Temp Comp Configuration**

The Quarter-Bridge Temp Comp configuration has the following characteristics:

- Uses active strain gage element and one passive (dummy) strain gage element.
- The active strain gage element is mounted in the direction of axial or bending strain.
- The passive (dummy) strain gage element,  $R_3$ , is mounted in close thermal contact with the strain specimen to compensate for temperature, but is not bonded to the specimen; it does not respond to the axial or bending strain of the specimen.

Although it is not necessary, the dummy strain gage element is usually mounted perpendicular to the axis of strain.

Figure 22 shows how to connect a Quarter-Bridge Temp Comp circuit to the DT9838 when using the general-purpose STP STRAIN accessory and remote sensing.

**Note:** When remote sensing is used, enter 0  $\Omega$  for the lead wire correction coefficient in software. Refer to [page 100](#) for more information.

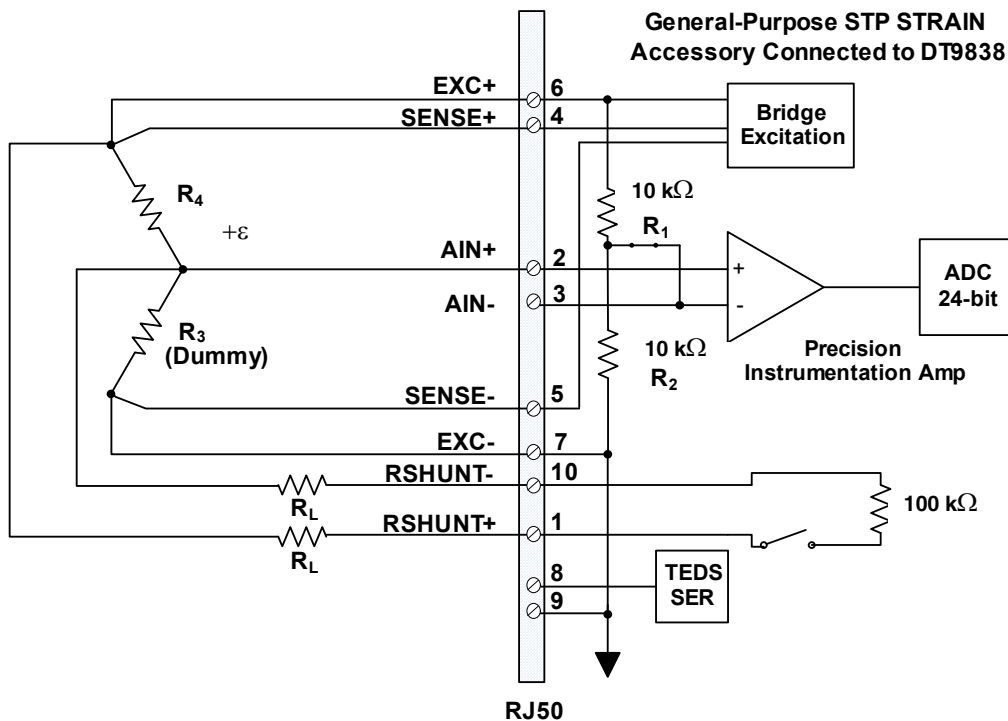

Figure 21: Connecting a Quarter Bridge Temp Comp Circuit to the DT9838 When Using the General-Purpose STP STRAIN Accessory and Remote Sensing

### Remote Sensing In Quarter-Bridge Temp Comp Configurations

Although not required for operation in Quarter-Bridge Temp Comp configurations, it is recommended that you connect the bridge SENSE+ and SENSE- lines, as shown in [Figure 21](#) to minimize voltage drops caused by the lead wire resistance of the EXC+ and EXC- lines. This is most important in applications where long wires and/or small gauge wires, which have greater resistance, are used.

If you do not use remote sense leads, you must connect the sense leads to the excitation leads (connect SENSE+ to EXC+ and SENSE- to EXC-), as shown in [Figure 22](#), to ensure proper bridge voltage regulation. If the lead wire resistance is known, you can enter the lead wire correction coefficient in software. Refer to [page 100](#) for more information.



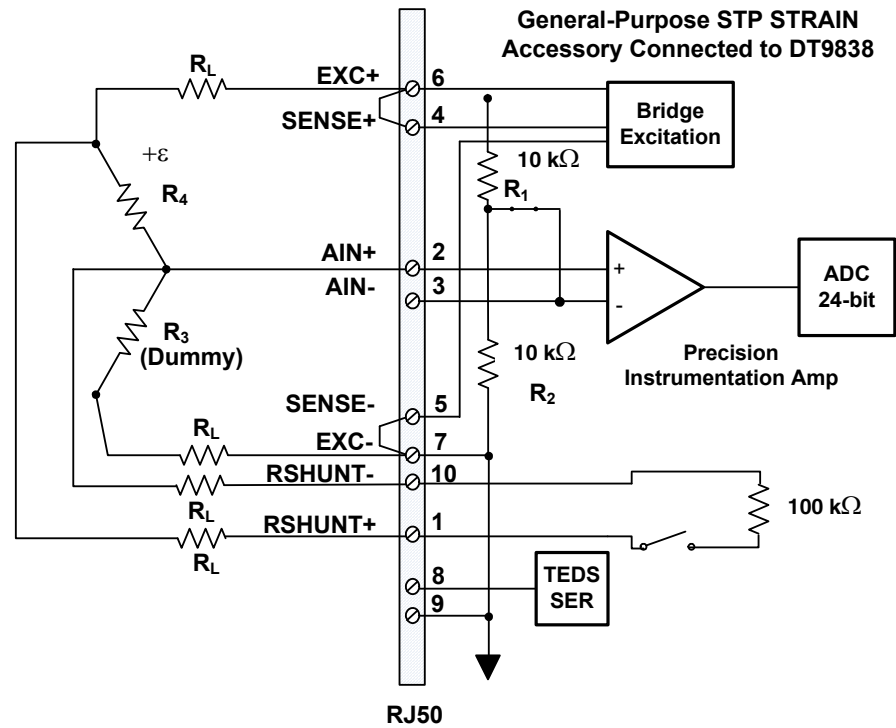

**Figure 22: Connecting a Quarter Bridge Temp Comp Circuit to the DT9838 When Using the General-Purpose STP STRAIN Accessory Without Remote Sensing**

### ***Shunt Calibration in Quarter-Bridge Temp Comp Configurations***

When setting up your strain gage, you can use shunt calibration to correct for errors due to lead wire resistance ( $R_L$ ) in the excitation wiring. Refer to [page 102](#) for the equations used for shunt calibration in Quarter-Bridge Temp Comp configurations.

To perform shunt calibration in a quarter-bridge configuration using the internal 100 k $\Omega$  resistor, connect the internal RSHUNT+ and RSHUNT- lines across gage  $R_3$  or  $R_4$ , as shown in [Figure 21](#) and [Figure 22](#). You can then use software to switch in 100 k $\Omega$  across gage  $R_3$  or  $R_4$  when no strain is applied to the specimen, creating a known change in the bridge output. You can then use software to measure the output of the bridge, compare it to the expected bridge output value, and adjust the gain of the DT9838 to compensate for these errors.

Once you have verified your setup, you can disconnect the RSHUNT+ and RSHUNT- lines, if desired.

Refer to your software documentation for more information about shunt calibration.

## Connecting Half-Bridge Circuits

The DT9838 module supports the following half-bridge configurations:

- Half-Bridge Poisson (Bending or Axial)
- Half-Bridge Bending

This section describes how to wire the Half-Bridge Poisson and Half-Bridge Bending circuits to the DT9838 module. The wiring diagram is the same for all half-bridge configurations; however, the meaning of  $R_3$  and  $R_4$  differs depending on the configuration you choose. For more information about these bridge configuration types, refer to [page 95](#).

### Wiring a Half-Bridge Poisson Circuit

The Half-Bridge Poisson configuration, shown in [Figure 23](#), measures either axial or bending strain, compensates for temperature, and compensates for the aggregate effect on the principle strain measurement due to the Poisson ratio of the specimen material.

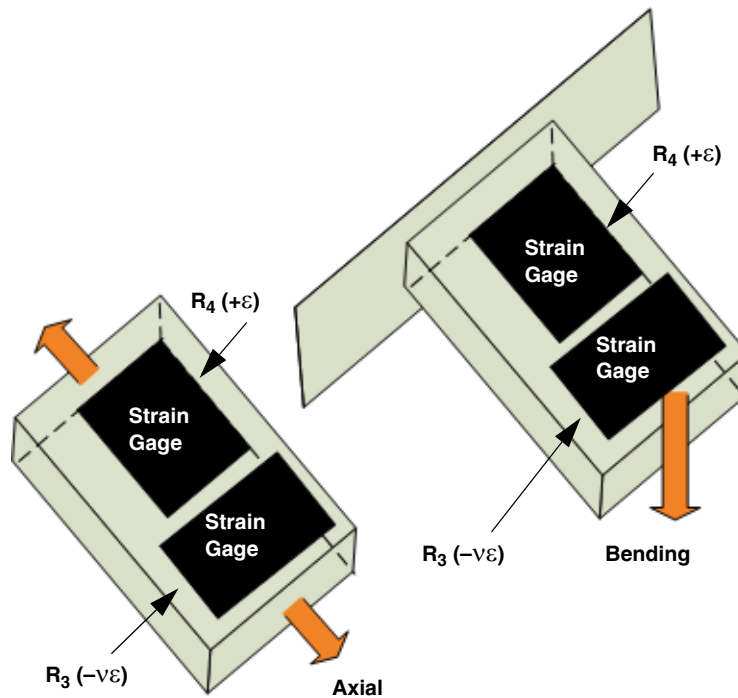

Figure 23: Half-Bridge Poisson Configuration

The Half-Bridge Poisson configuration has the following characteristics:

- Uses two active strain gage elements.
- One strain gage element,  $R_4 (+\epsilon)$ , is mounted in the direction of axial strain.

The other strain gage element,  $R_3 (-\nu\epsilon)$ , is mounted transversely (perpendicular) to the axis of strain to measure the Poisson effect.

- The DT9838 provides two internal  $10\text{ k}\Omega$  resistors  $R_1$  and  $R_2$ , to complete the sensor side of the bridge circuit.

Figure 24 shows how to connect a Half-Bridge Poisson circuit to the DT9838 when using the general-purpose STP STRAIN accessory and remote sensing.

---

**Note:** When remote sensing is used, enter  $0\ \Omega$  for the lead wire correction coefficient in software. Refer to [page 100](#) for more information.

---

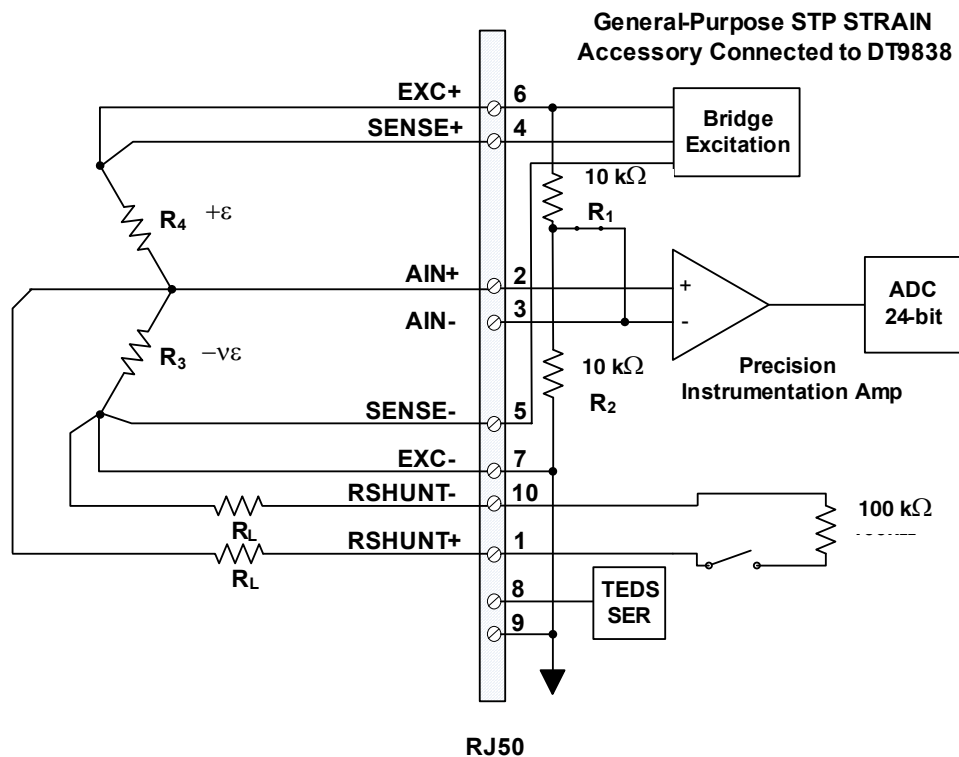

**Figure 24: Connecting a Half-Bridge Poisson Circuit to the DT9838 When Using the General-Purpose STP STRAIN Accessory and Remote Sensing**

## Remote Sensing In Half-Bridge Poisson Configurations

Although not required for operation in Half-Bridge Poisson configuration, it is recommended that you connect the bridge SENSE+ and SENSE- lines, as shown in Figure 24 to minimize voltage drops caused by the lead wire resistance of the EXC+ and EXC- lines. This is most important in applications where long wires and/or small gauge wires, which have greater resistance, are used.

If you do not use remote sense lines, you must connect the sense leads to the excitation leads (connect SENSE+ to EXC+ and SENSE- to EXC-), as shown in Figure 25, to ensure proper bridge voltage regulation. If the lead wire resistance is known, you can enter the lead wire correction coefficient in software. Refer to page 100 for more information.

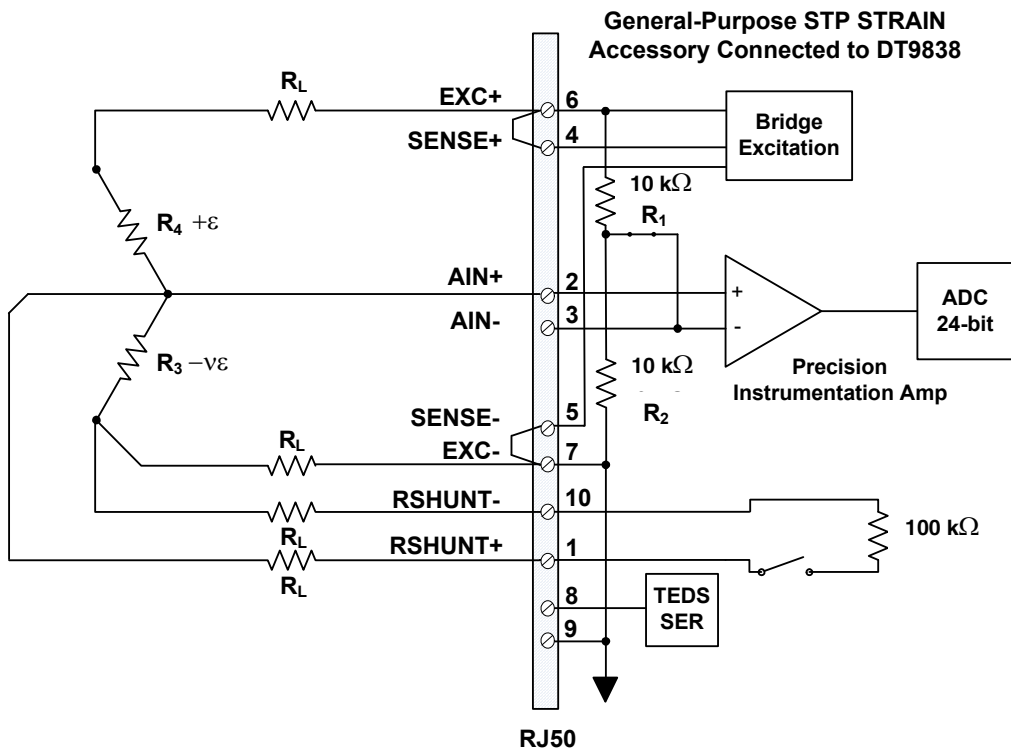

Figure 25: Connecting a Half-Bridge Poisson Circuit to the DT9838 When Using the General-Purpose STP STRAIN Accessory Without Remote Sensing

## **Shunt Calibration in Half-Bridge Poisson Configurations**

When setting up your strain gage, you can use shunt calibration to correct for errors due to lead wire resistance ( $R_L$ ) in the excitation wiring. Refer to [page 102](#) for the equation used for shunt calibration in a Half-Bridge Poisson configuration.

To perform shunt calibration in a Half-Bridge Poisson configuration using the internal 100 k $\Omega$  resistor, connect the internal RSHUNT+ and RSHUNT- lines across gage  $R_3$  or  $R_4$ , as shown in [Figure 24](#) and [Figure 25](#). You can then use software to switch in 100 k $\Omega$  across the selected gage when no strain is applied to the specimen, creating a known change in the bridge output. Using software, you can then measure the output of the bridge, compare it to the expected bridge output value, and adjust the gain of the DT9838 to compensate for these errors.

Once you have performed the shunt calibration procedure, you can disconnect the RSHUNT+ and RSHUNT- lines, if desired.

Refer to your software documentation for more information about shunt calibration.

## Wiring a Half-Bridge Bending Circuit

The Half-Bridge Bending configuration, shown in [Figure 26](#), measures bending strain, rejects axial strain, and compensates for temperature.

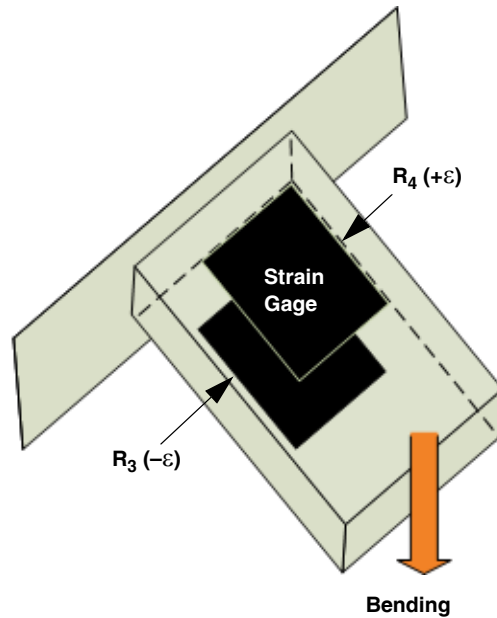

**Figure 26: Half-Bridge Bending Configuration**

The Half-Bridge Bending configuration has the following characteristics:

- Uses two active strain gage elements.
- One strain gage element,  $R_4 (+\varepsilon)$ , is mounted in the direction of bending strain on the top of the specimen.  
The other strain gage element,  $R_3 (-\varepsilon)$ , is mounted in the direction of bending strain on the bottom of the specimen.
- The DT9838 provides two internal  $10\text{ k}\Omega$  resistors ( $R_1$  and  $R_2$ ) to complete the sensor side of the bridge circuit.

[Figure 27](#) shows how to connect a Half-Bridge Bending circuit to the DT9838 when using the general-purpose STP STRAIN accessory and remote sensing.

---

**Note:** When remote sensing is used, enter  $0\ \Omega$  for the lead wire correction coefficient in software. Refer to [page 100](#) for more information.

---

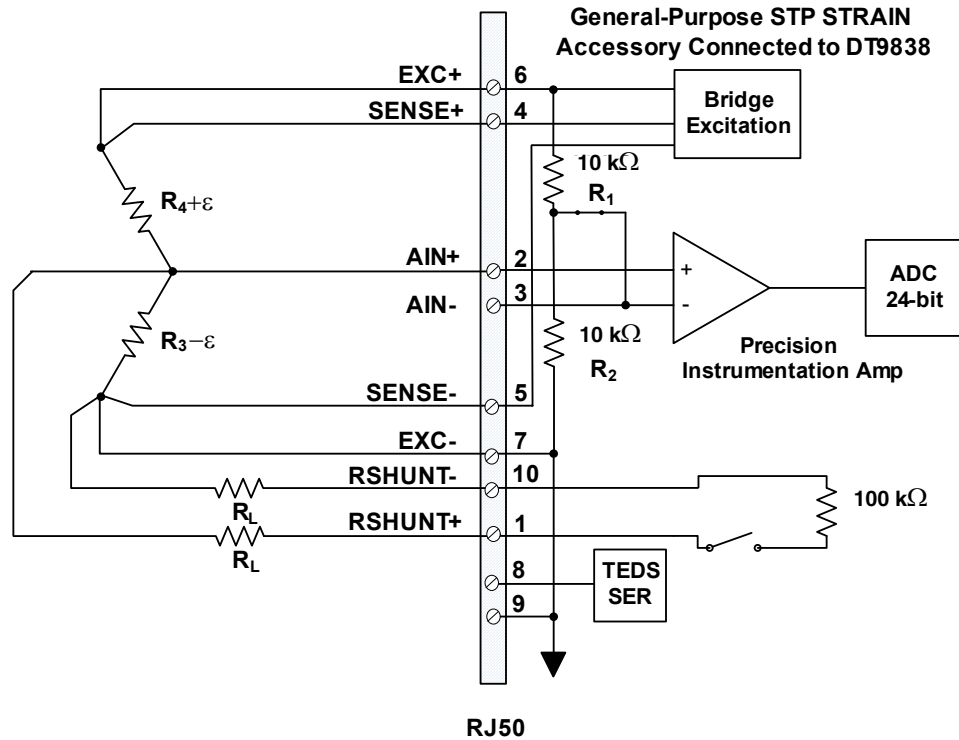
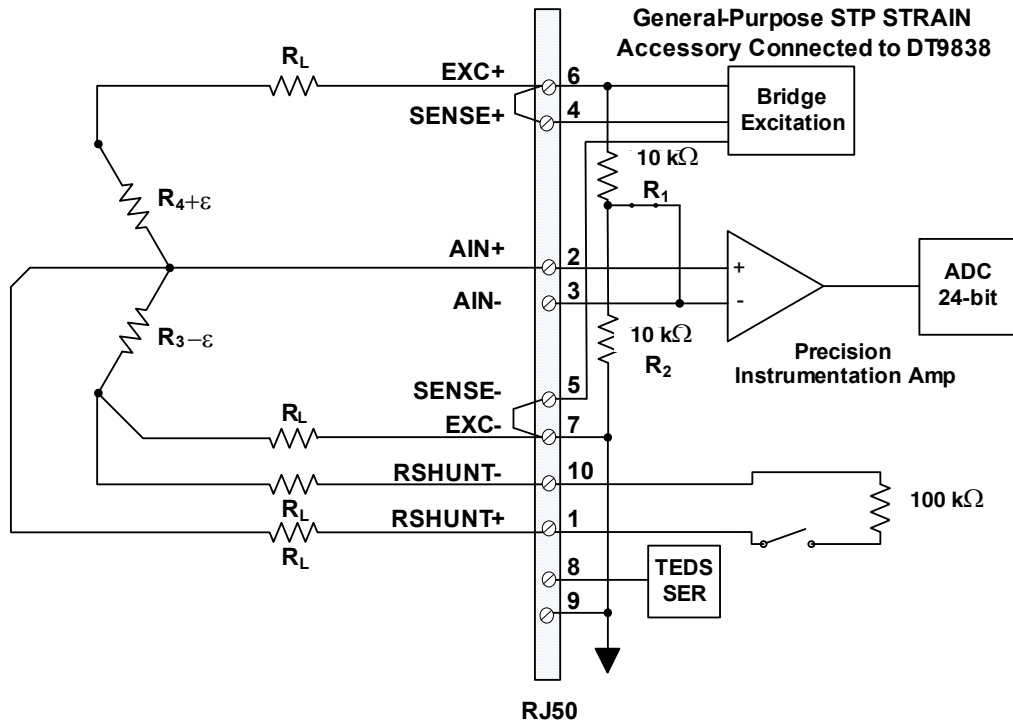

**Figure 27: Connecting a Half-Bridge Bending Circuit to the DT9838 When Using the General-Purpose STP STRAIN Accessory and Remote Sensing**

### **Remote Sensing In Half-Bridge Bending Configurations**

Although not required for operation in Half-Bridge Bending configurations, it is recommended that you connect the bridge SENSE+ and SENSE- lines, as shown in [Figure 27](#) to minimize voltage drops caused by the lead wire resistance of the EXC+ and EXC- lines. This is most important in applications where long wires and/or small gauge wires, which have greater resistance, are used.

If you do not use remote sense lines, you must connect the sense leads to the excitation leads (connect SENSE+ to EXC+ and SENSE- to EXC-), as shown in [Figure 28](#), to ensure proper bridge voltage regulation. If the lead wire resistance is known, you can enter the lead wire correction coefficient in software. Refer to [page 100](#) for more information.



**Figure 28: Connecting a Half-Bridge Bending Circuit to the DT9838 When Using the General-Purpose STP STRAIN Accessory Without Remote Sensing**

### ***Shunt Calibration in Half-Bridge Bending Configurations***

When setting up your strain gage, you can use shunt calibration to correct for errors due to lead wire resistance ( $R_L$ ) in the excitation wiring. Refer to [page 102](#) for the equation used for shunt calibration in a Half-Bridge Bending configuration.

To perform shunt calibration in a Half-Bridge Bending configuration using the internal 100 k $\Omega$  resistor, connect the internal RSHUNT+ and RSHUNT- lines across gage  $R_3$  or  $R_4$ , as shown in [Figure 27](#) and [Figure 28](#). You can then use software to switch in 100 k $\Omega$  across the selected gage when no strain is applied to the specimen, creating a known change in the bridge output. Using software, you can then measure the output of the bridge, compare it to the expected bridge output value, and adjust the gain of the DT9838 to compensate for these errors.

Once you have performed the shunt calibration procedure, you can disconnect the RSHUNT+ and RSHUNT- lines, if desired.

Refer to your software documentation for more information about shunt calibration.



## Connecting Full-Bridge Circuits

The DT9838 module supports the following full-bridge configurations:

- Full-Bridge Bending
- Full-Bridge Bending Poisson
- Full-Bridge Axial Poisson

This section describes how to wire the Full-Bridge Bending, Full-Bridge Bending Poisson, and Full-Bridge Bending configurations to the DT9838 module. The wiring diagram is the same for all full-bridge configurations; however, the meaning of  $R_1$ ,  $R_2$ ,  $R_3$ , and  $R_4$  differs depending on the configuration you choose. For more information about these bridge configuration types, refer to [page 98](#).

### Wiring a Full-Bridge Bending Circuit

The Full-Bridge Bending configuration, shown in [Figure 29](#), measures bending strain. It also rejects axial strain, compensates for temperature, and compensates for lead resistance if remote sense lines are used.

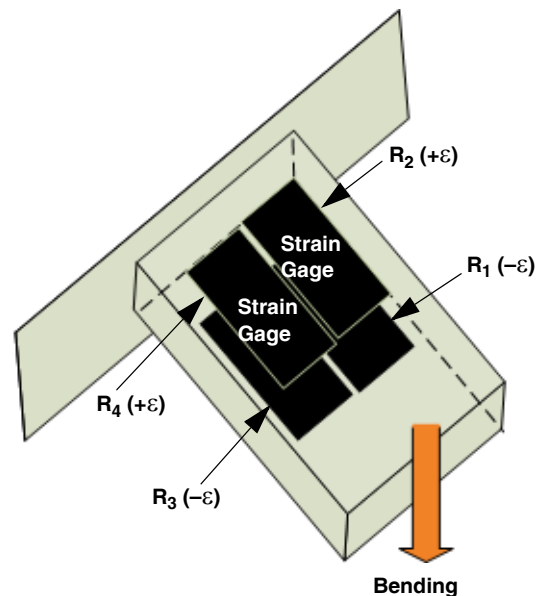

Figure 29: Full-Bridge Bending Configuration

The Full-Bridge Bending configuration has the following characteristics:

- Uses four active strain gages.
- Two strain gages,  $R_4 (+\epsilon)$  and  $R_2 (+\epsilon)$ , are mounted in the direction of bending strain on the top of the specimen.

The other two strain gages,  $R_3 (-\epsilon)$  and  $R_1 (-\epsilon)$ , are mounted in the direction of bending strain on the bottom of the specimen.

Figure 30 shows how to connect a Full-Bridge Bending circuit to the DT9838 when using the general-purpose STP STRAIN accessory and remote sensing.

---

**Note:** When remote sensing is used, enter  $0 \Omega$  for the lead wire correction coefficient in software. Refer to [page 100](#) for more information.

---

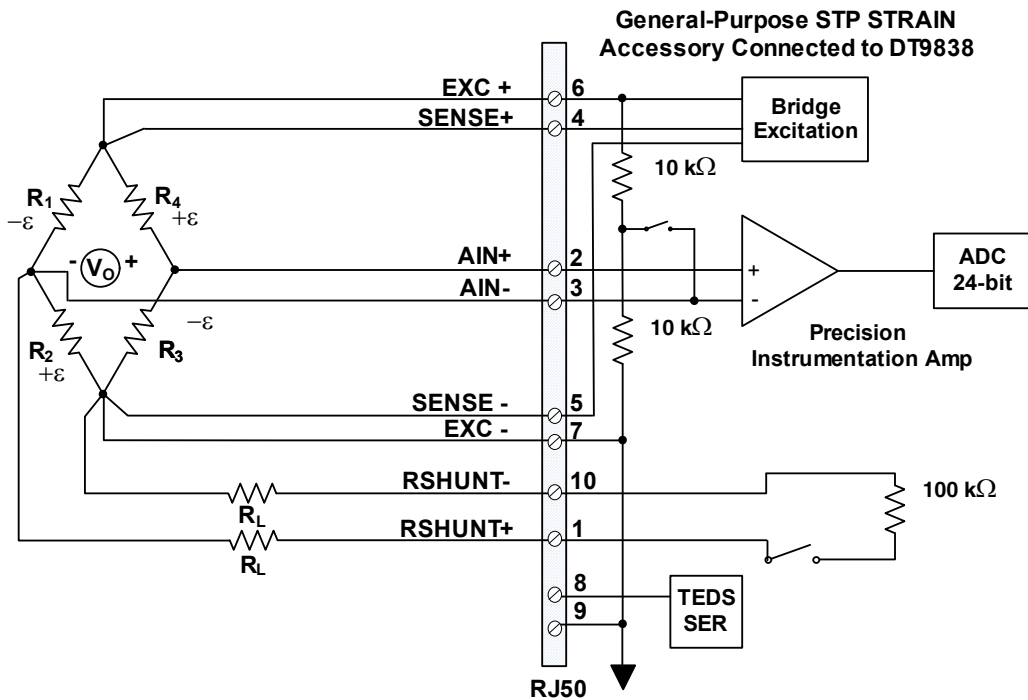

**Figure 30: Connecting a Full-Bridge Bending Circuit to the DT9838 When Using the General-Purpose STP STRAIN Accessory and Remote Sensing**

## Remote Sensing in Full-Bridge Bending Configurations

Although not required for operation, it is recommended that you connect the bridge SENSE+ and SENSE- leads, as shown in Figure 30 to minimize voltage drops caused by the lead wire resistance ( $R_L$ ) of the EXC+ and EXC- lines. This is most important in applications where long wires and/or small gauge wires, which have greater resistance, are used.

If you do not use remote sense leads, you must connect the sense leads to the excitation leads (connect SENSE+ to EXC+ and SENSE- to EXC-), as shown in Figure 31, to ensure proper bridge voltage regulation. If the lead wire resistance is known, you can enter the lead wire correction coefficient in software. Refer to page 100 for more information.

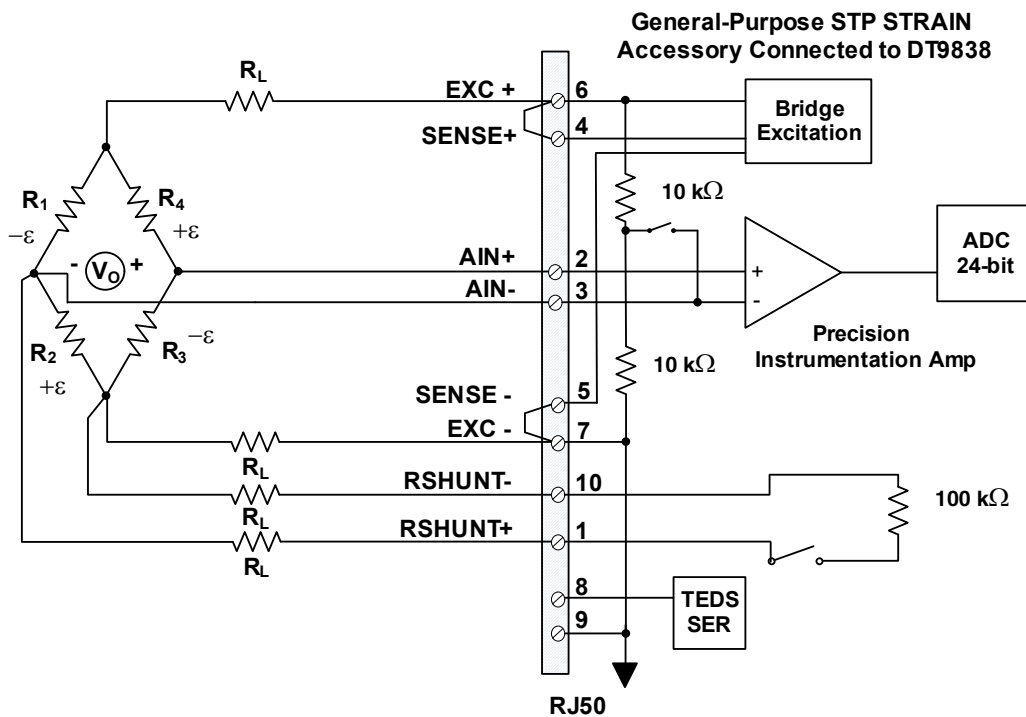

Figure 31: Connecting a Full-Bridge Bending Circuit to the DT9838 When Using the General-Purpose STP STRAIN Accessory Without Remote Sensing

## Shunt Calibration in Full-Bridge Bending Configurations

When setting up your strain gage, you can use shunt calibration to correct for errors due to lead wire resistance ( $R_L$ ) in the excitation wiring. Refer to page 103 for the equation used for shunt calibration in a Full-Bridge Bending configuration.

To perform shunt calibration in a full-bridge configuration using the internal 100 kΩ resistor, connect the RSHUNT+ and RSHUNT- lines across any active gage ( $R_1$ ,  $R_2$ ,  $R_3$ , or  $R_4$ ), as shown in Figure 30 and Figure 31. You can then use software to switch 100 kΩ across the selected gage when no strain is applied to the specimen, creating a known change in the bridge output.

Using software, you can then measure the output of the bridge, compare it to the expected bridge output value, and adjust the gain of the DT9838 to compensate for these errors.

Once you have performed the shunt calibration procedure, you can disconnect the RSHUNT+ and RSHUNT- lines, if desired.

Refer to your software documentation for more information about shunt calibration.

## Wiring a Full-Bridge Bending Poisson Configuration

The Full-Bridge Bending Poisson configuration, shown in [Figure 32](#), measures bending strain. It also rejects axial strain, compensates for temperature, compensates for lead resistance, and compensates for the aggregate effect on the principle strain measurement due to the Poisson's ratio of the specimen material.

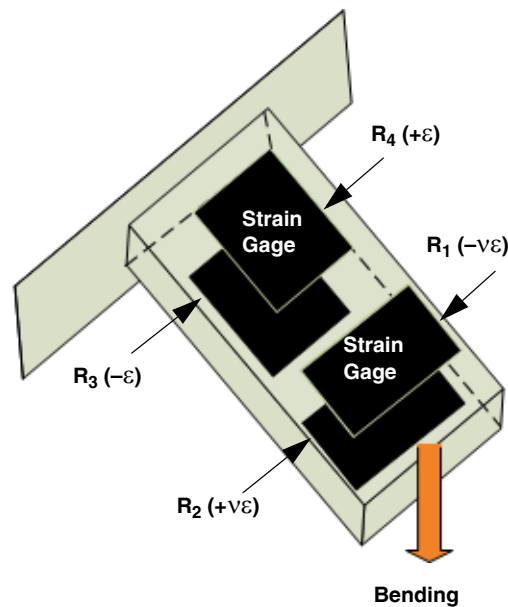

**Figure 32: Full-Bridge Bending Poisson Configuration**

The Full-Bridge Bending Poisson configuration has the following characteristics:

- Uses four active strain gages.
- Two strain gages,  $R_4 (+\epsilon)$  and  $R_3 (-\epsilon)$ , are mounted in the direction of bending strain, with one mounted on the top and the other on the bottom of the specimen.

The other two strain gages,  $R_2 (+\nu\epsilon)$  and  $R_1 (-\nu\epsilon)$ , measure the Poisson effect and are mounted transversely (perpendicular) to the axis of bending strain, with one mounted on the top and the other on the bottom of the specimen.

[Figure 30](#) shows how to connect a Full-Bridge Bending Poisson circuit to the DT9838 when using the general-purpose STP STRAIN accessory and remote sensing.

**Note:** When remote sensing is used, enter 0  $\Omega$  for the lead wire correction coefficient in software. Refer to [page 100](#) for more information.

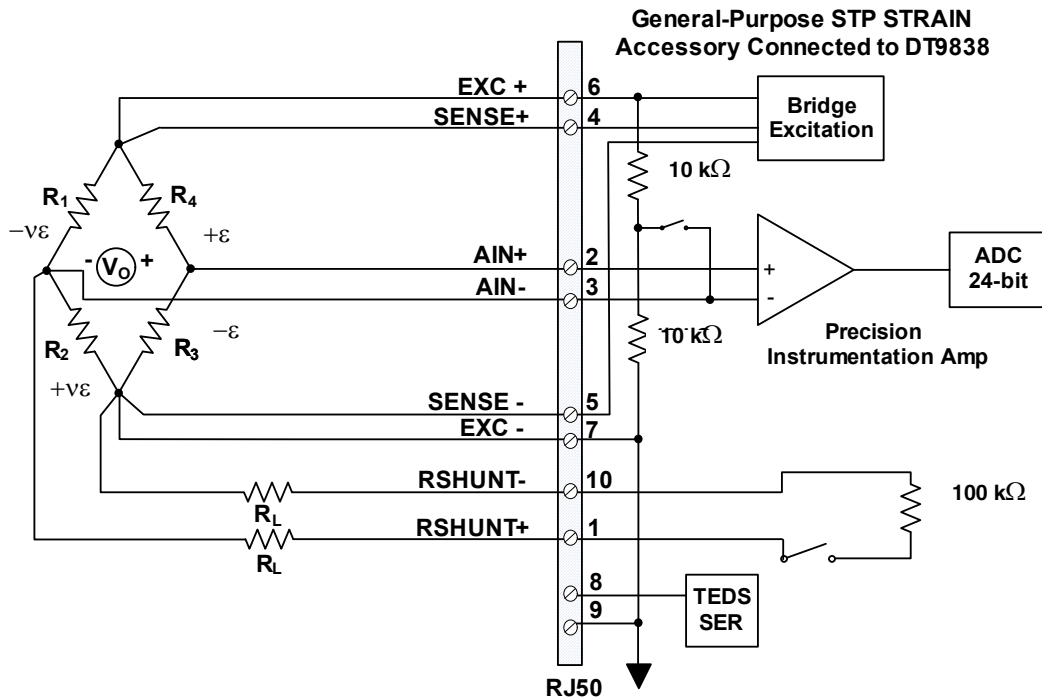
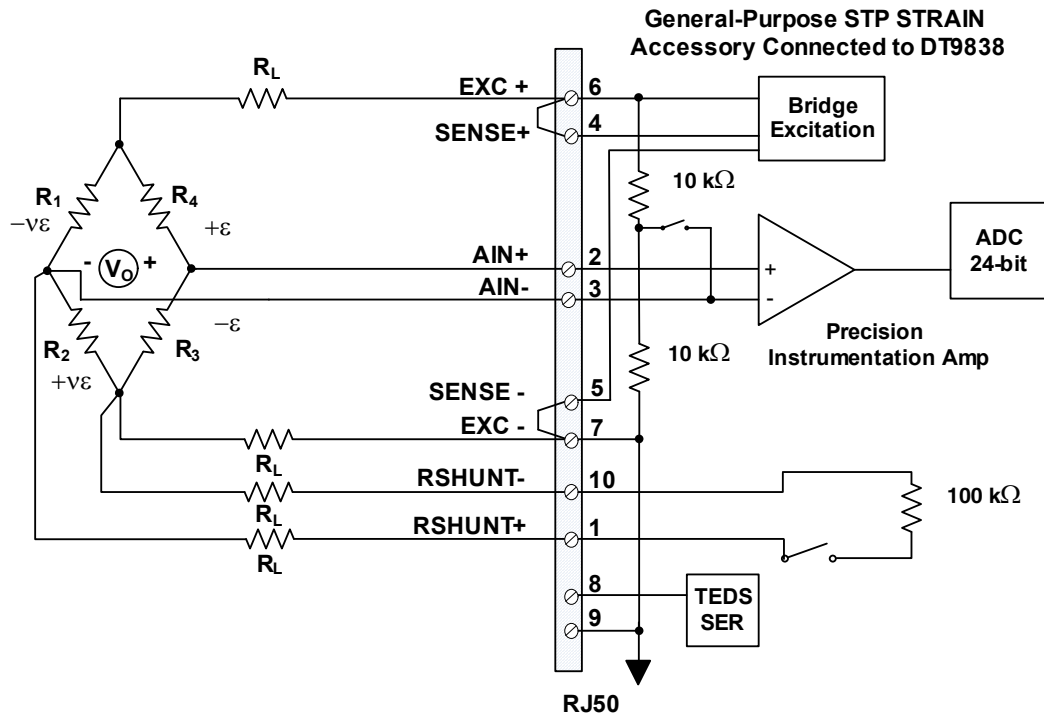

**Figure 33: Connecting a Full-Bridge Bending Poisson Circuit to the DT9838 When Using the General-Purpose STP STRAIN Accessory and Remote Sensing**

### **Remote Sensing in Full-Bridge Bending Poisson Configurations**

Although not required for operation, it is recommended that you connect the bridge SENSE+ and SENSE- leads, as shown in [Figure 33](#), to minimize voltage drops caused by the lead wire resistance ( $R_L$ ) of the EXC+ and EXC- lines. This is most important in applications where long wires and/or small gauge wires, which have greater resistance, are used.

If you do not use remote sense leads, you must connect the sense leads to the excitation leads (connect SENSE+ to EXC+ and SENSE- to EXC-), as shown in [Figure 34](#), to ensure proper bridge voltage regulation. If the lead wire resistance is known, you can enter the lead wire correction coefficient in software. Refer to [page 100](#) for more information.



**Figure 34: Connecting a Full-Bridge Bending Poisson Circuit to the DT9838 When Using the General-Purpose STP STRAIN Accessory Without Remote Sensing**

### **Shunt Calibration in Full-Bridge Bending Poisson Configurations**

When setting up your strain gage, you can use shunt calibration to correct for errors due to lead wire resistance ( $R_L$ ) in the excitation wiring. Refer to [page 103](#) for the equation used for shunt calibration in a Full-Bridge Bending Poisson configuration.

To perform shunt calibration in a full-bridge configuration using the internal 100 kΩ resistor, connect the RSHUNT+ and RSHUNT- lines across any active gage ( $R_1, R_2, R_3, \text{ or } R_4$ ), as shown in [Figure 33](#) and [Figure 34](#). You can then use software to switch 100 kΩ across the selected gage when no strain is applied to the specimen, creating a known change in the bridge output. Using software, you can then measure the output of the bridge, compare it to the expected bridge output value, and adjust the gain of the DT9838 to compensate for these errors.

Once you have performed the shunt calibration procedure, you can disconnect the RSHUNT+ and RSHUNT- lines, if desired.

Refer to your software documentation for more information about shunt calibration.

## Wiring a Full-Bridge Axial Poisson Circuit

The Full-Bridge Axial Poisson configuration, shown in [Figure 35](#), measures axial strain. It also compensates for temperature, rejects bending strain, compensates for lead resistance if remote sense lines are used, and compensates for the aggregate effect on the principle strain measurement due to the Poisson ratio of the specimen material.

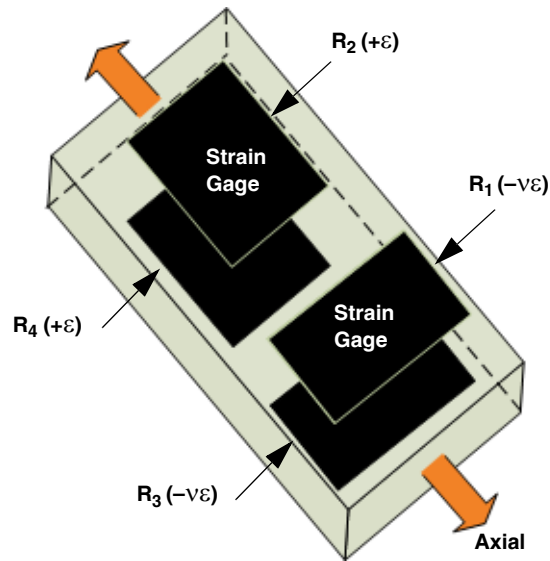

**Figure 35: Full-Bridge Type Axial Poisson Configuration**

The Full-Bridge Axial Poisson configuration has the following characteristics:

- Uses four active strain gages.
- Two strain gages,  $R_4 (+\epsilon)$  and  $R_2 (+\epsilon)$ , are mounted in the direction of axial strain, with one mounted on the top and the other on the bottom of the specimen.

The other two strain gages,  $R_3 (-\nu\epsilon)$  and  $R_1 (-\nu\epsilon)$ , measure the Poisson effect and are mounted transversely (perpendicular) to the axis of axial strain, with one mounted on the top and the other on the bottom of the specimen.

[Figure 36](#) shows how to connect a Full-Bridge Axial Poisson circuit to the DT9838 when using the general-purpose STP STRAIN accessory and remote sensing.

---

**Note:** When remote sensing is used, enter  $0 \Omega$  for the lead wire correction coefficient in software. Refer to [page 100](#) for more information.

---

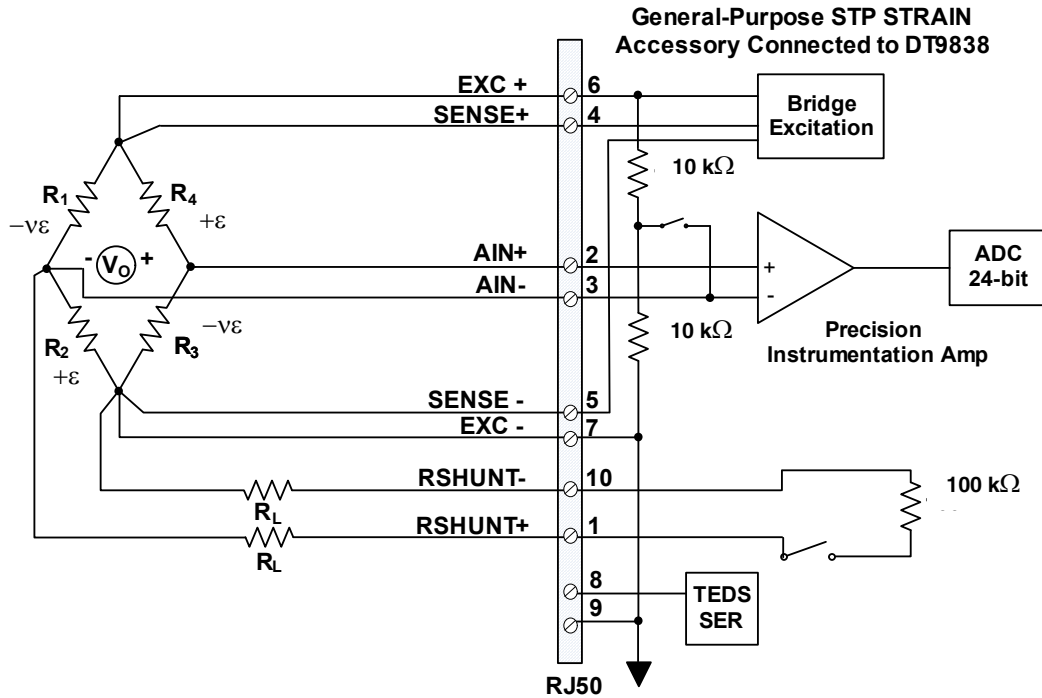

Figure 36: Connecting a Full-Bridge Axial Poisson Circuit to the DT9838 When Using the General-Purpose STP STRAIN Accessory and Remote Sensing

### Remote Sensing in Full-Bridge Axial Poisson Configurations

Although not required for operation, it is recommended that you connect the bridge SENSE+ and SENSE- leads, as shown in [Figure 36](#), to minimize voltage drops caused by the lead wire resistance ( $R_L$ ) of the EXC+ and EXC- lines. This is most important in applications where long wires and/or small gauge wires, which have greater resistance, are used.

If you do not use remote sense leads, you must connect the sense leads to the excitation leads (connect SENSE+ to EXC+ and SENSE- to EXC-), as shown in [Figure 37](#), to ensure proper bridge voltage regulation. If the lead wire resistance is known, you can enter the lead wire correction coefficient in software. Refer to [page 100](#) for more information.



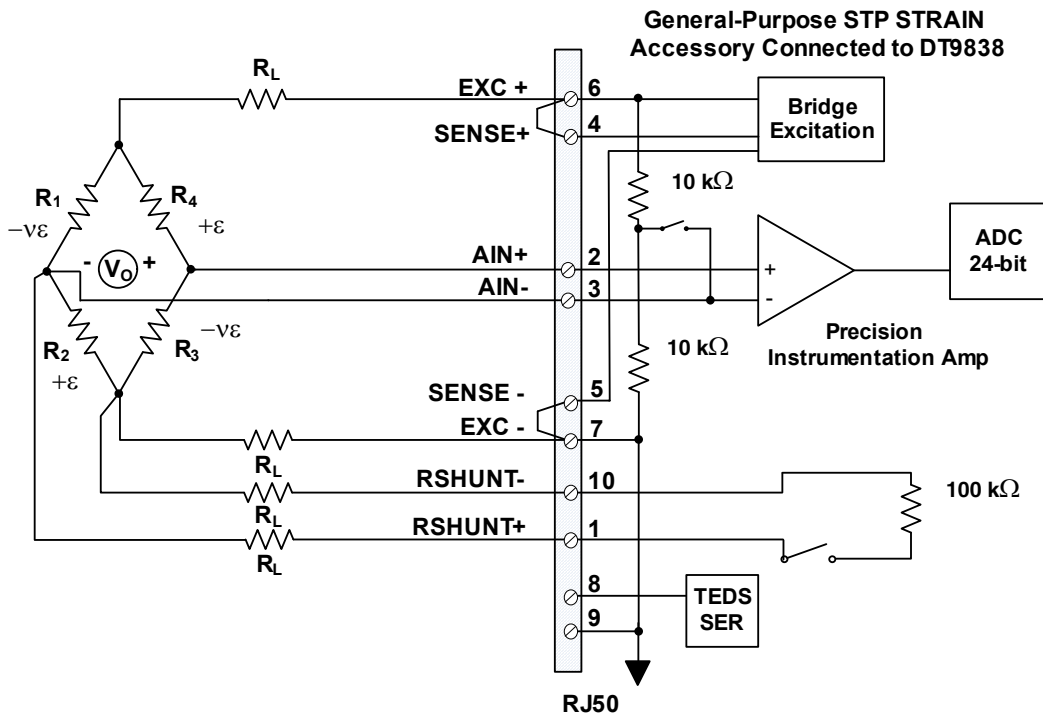

**Figure 37: Connecting a Full-Bridge Axial Poisson Circuit to the DT9838 When Using the General-Purpose STP STRAIN Accessory Without Remote Sensing**

### ***Shunt Calibration in Full-Bridge Axial Poisson Configurations***

When setting up your strain gage, you can use shunt calibration to correct for errors due to lead wire resistance ( $R_L$ ) in the excitation wiring. Refer to [page 103](#) for the equation used for shunt calibration in a Full-Bridge Axial Poisson configuration.

To perform shunt calibration in a Full-Bridge Axial Poisson configuration using the internal 100 kΩ resistor, connect the RSHUNT+ and RSHUNT- lines across any active gage ( $R_1$ ,  $R_2$ ,  $R_3$ , or  $R_4$ ), as shown in [Figure 36](#) and [Figure 37](#). You can then use software to switch 100 kΩ across the selected gage when no strain is applied to the specimen, creating a known change in the bridge output. Using software, you can then measure the output of the bridge, compare it to the expected bridge output value, and adjust the gain of the DT9838 to compensate for these errors.

Once you have performed the shunt calibration procedure, you can disconnect the RSHUNT+ and RSHUNT- lines, if desired.

Refer to your software documentation for more information about shunt calibration.

## Connecting Load Cells and Other Transducers

The DT9838 supports load cells (force sensors) as well as pressure transducers, and/or torque sensors that are based on the Wheatstone bridge.

These transducers typically use a full-bridge configuration with a 350  $\Omega$  nominal bridge resistance.

Many large load cells use the remote sense wires, as they are located farther away from the DT9838. Smaller load cells, which are located closer to the DT9838 typically, do not use remote sense lines; instead, the excitation (EXC+ and EXC-) and remote sense (SENSE+ and SENSE-) lines are connected at the DT9838.

Figure 38 shows how to connect load cells and other sensors that use remote sensing to the DT9838 when connected to the general-purpose STP STRAIN accessory. Figure 39 shows how to connect load cells and other sensors that do not use remote sensing to the DT9838 when connected to the general-purpose STP STRAIN accessory.

**Notes:** In load-cell configurations, the RSHUNT- and RSHUNT+ lines are not used, but optionally can be connected at the DT9838. TEDS connections are also optional.

Refer to the sensor manufacturer for information on wiring to your sensor type.

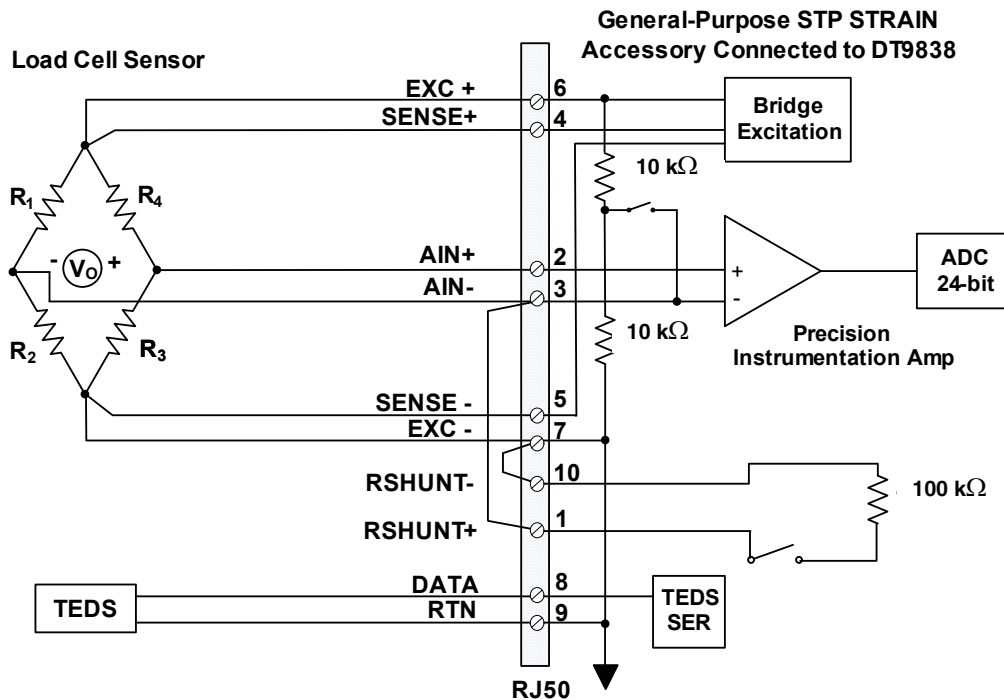

Figure 38: Connecting a Load Cell or Other Transducer to the DT9838 When Using the General-Purpose STP STRAIN Accessory and Remote Sensing

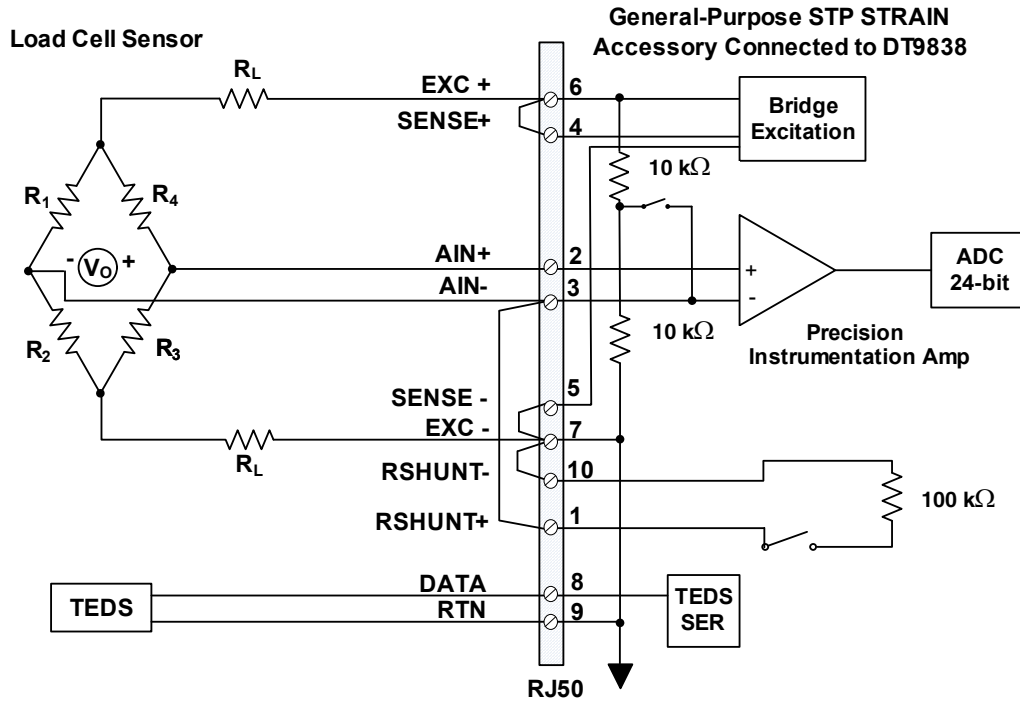
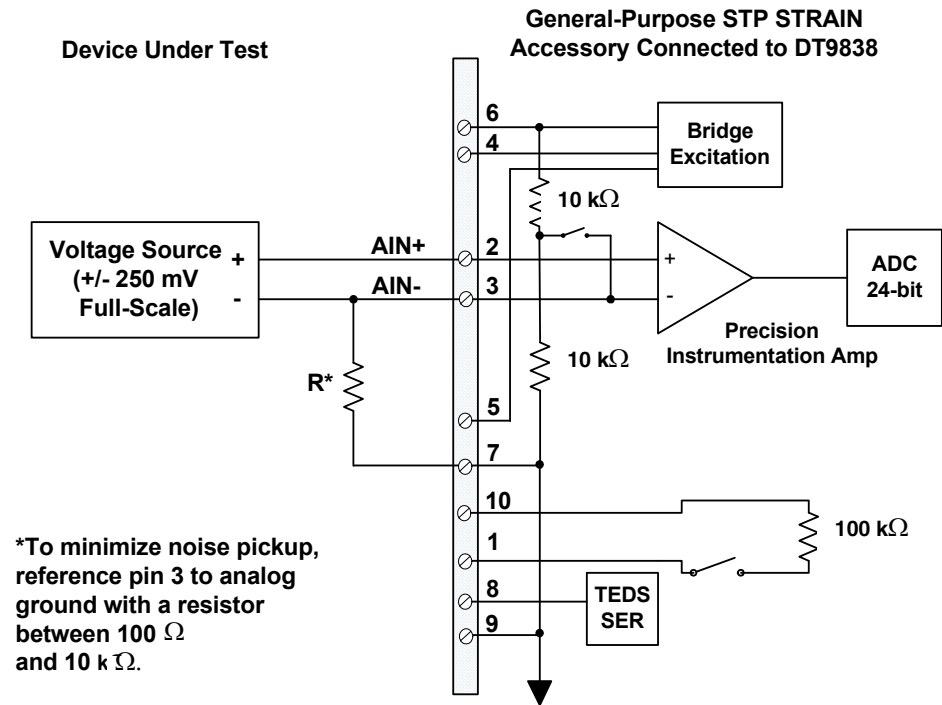

Figure 39: Connecting a Load Cell or Other Transducer to the DT9838 Without Using Remote Sensing

## Connecting Voltage Inputs

Figure 40 shows how to connect a voltage input source to a channel of the DT9838 when it is connected to a general-purpose STP STRAIN accessory. Note that the voltage source must be in the  $\pm 250$  mV full-scale range.



**Figure 40: Connecting Voltage Inputs to the DT9838 When Using the General-Purpose STP STRAIN Accessory**

---

**Note:** For best accuracy when connecting voltage inputs, use twisted-pair wires.

---

## Connecting a Tachometer Input Signal

You can connect a  $\pm 30$  V tachometer input signal to External Trigger and Tachometer connector (J6) on the DT9838 module, as shown in [Figure 41](#).

**Note:** In software, you can read tachometer measurements as part of the analog input channel list. Refer to [page 110](#) for more information on tachometer measurements.

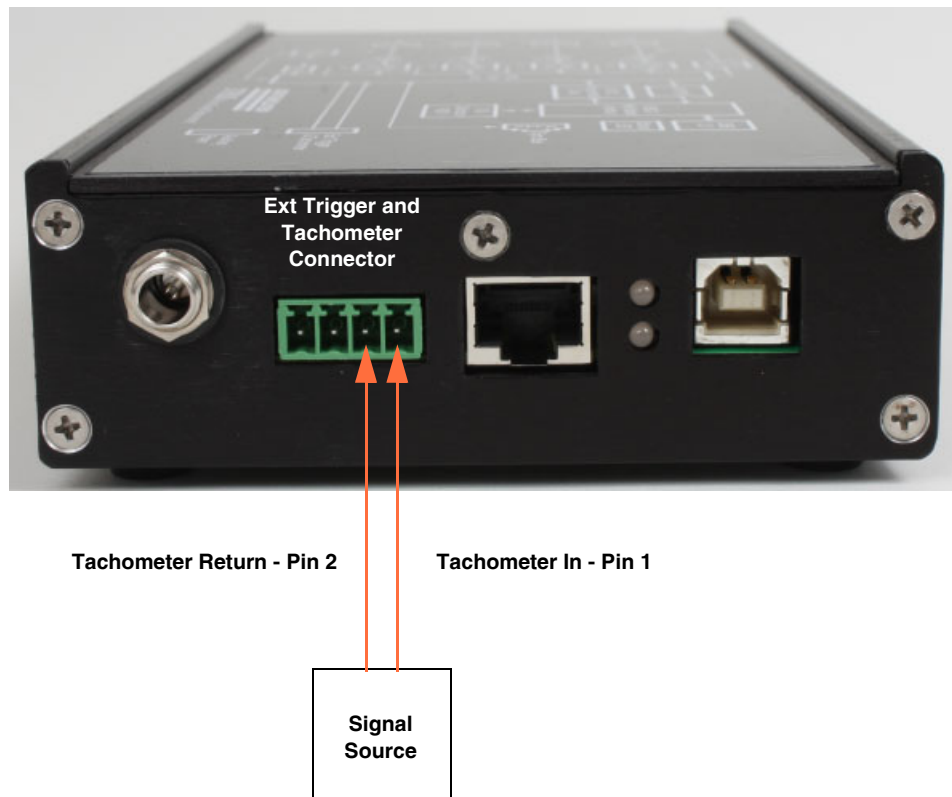

Figure 41: Connecting a Tachometer Input Signal to the DT9838 Module

## Connecting an External Trigger Signal

You can connect an external digital trigger signal to the External Trigger and Tachometer connector (J6) on the DT9838 module, as shown in [Figure 42](#). Refer to [page 110](#) for more information on the external digital trigger.

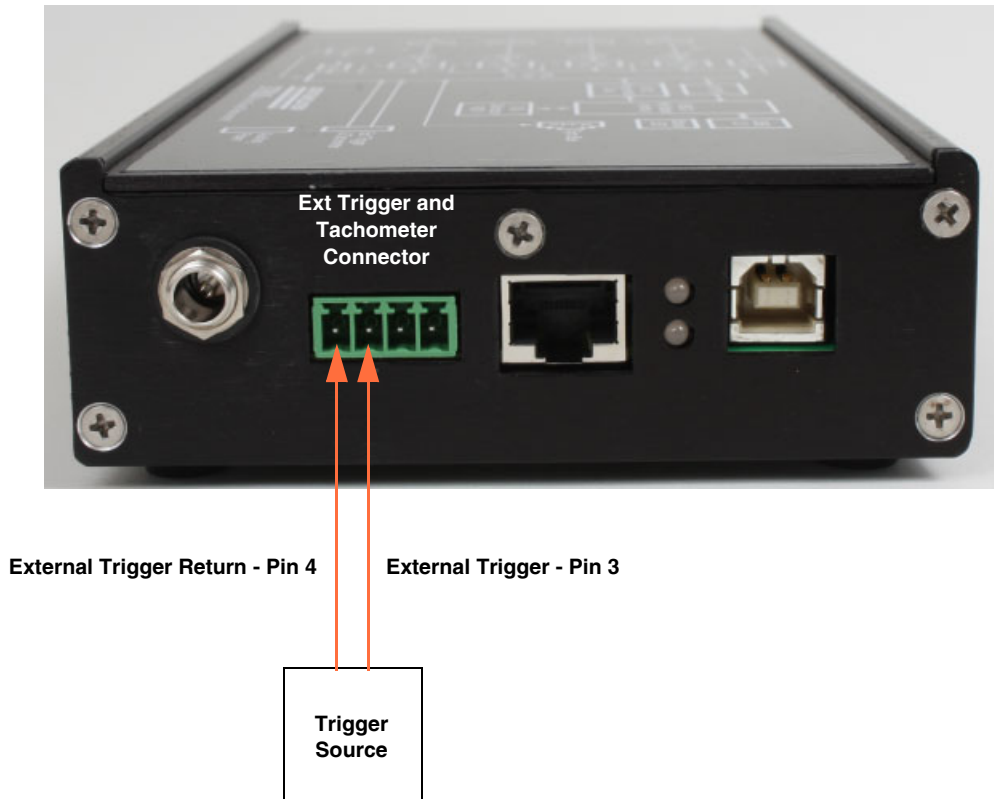
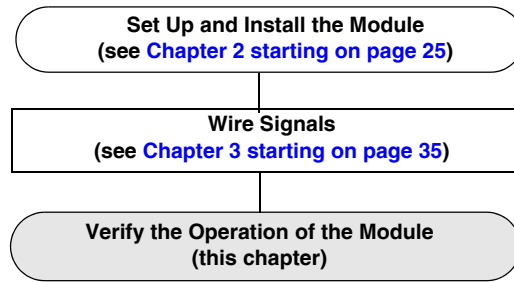

Figure 42: Connecting an External Trigger Input Signal to the DT9838 Module



## ***Verifying the Operation of a Module***

Select the Device .....	73
Measure Strain Gage Data .....	76



You can verify the operation of a DT9838 module using the QuickDAQ application.

QuickDAQ allows you to acquire and analyze data from all Data Translation USB and Ethernet devices, except the DT9841 Series, DT9817, DT9835, and DT9853/54. This chapter describes how to verify the operation of a DT9838 module using the QuickDAQ base version.



## Select the Device

To get started with your DT9838 module and QuickDAQ, follow these steps:

1. Connect the DT9838 module to the USB port of your computer, and connect your strain gage sensors to the module.
2. Start the QuickDAQ application.  
*The Device Selection window appears.*

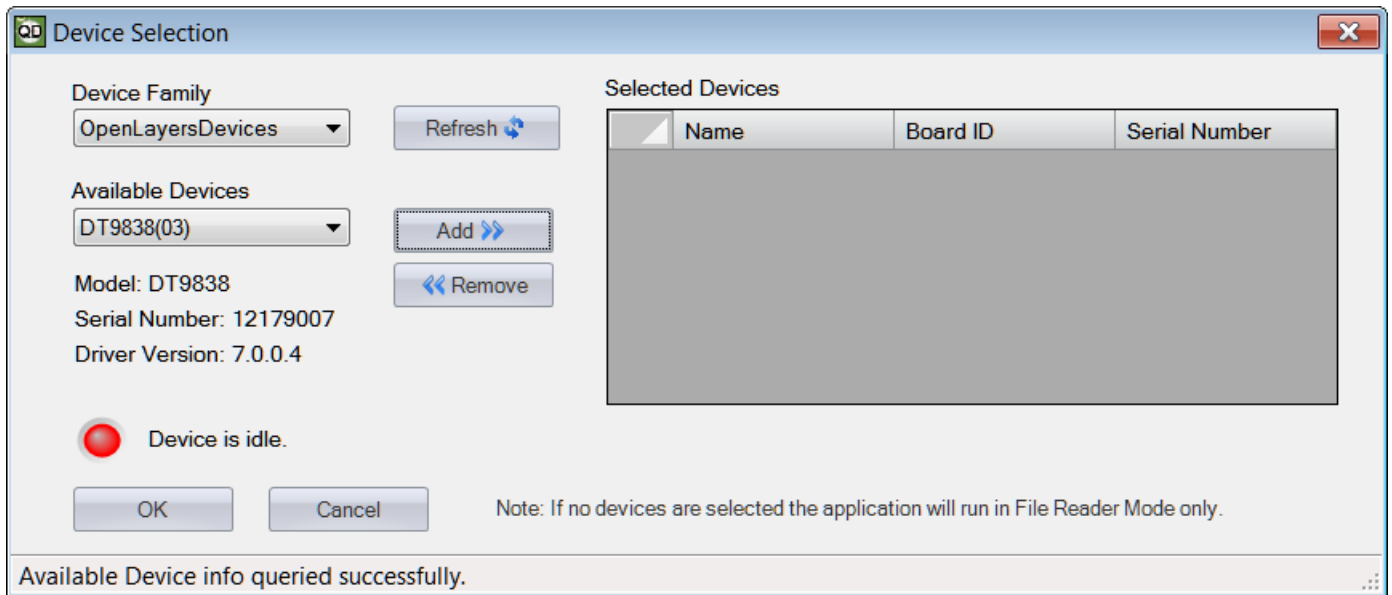

3. For the Device Family selection, select **OpenLayersDevices**.  
By default, the application "discovers" all devices that are available for the specified device family and displays the module name for the USB devices in the drop-down list. If you want to refresh this list to determine if other devices are available, click **Refresh**.
4. Select the module name for the DT9838 module that you want to use from the list of Available Devices, and click **Add**.  
*Information about the device, including the model number, serial number, firmware version, driver version, and scanning status is displayed.*

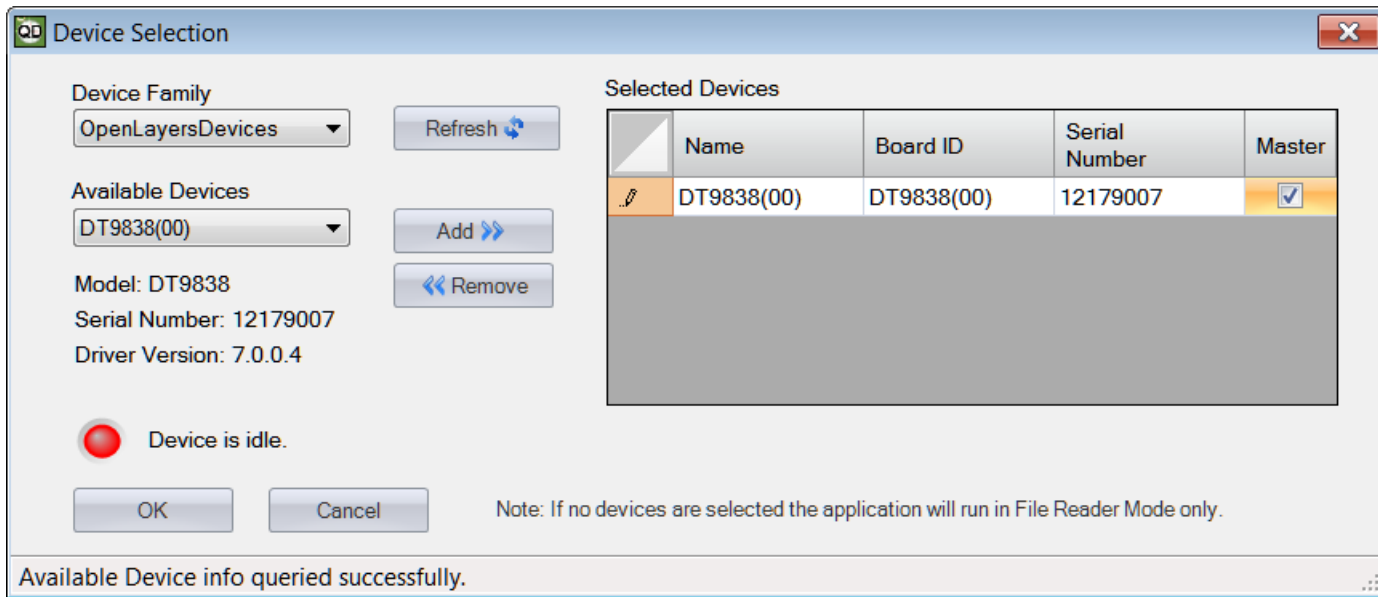

5. If you want to rename your device, do the following:
  - a. Click the Row Selector button for the device.
  - b. Click the IP address or module name in the **Name** column to highlight it and enter a meaningful name to represent each available device.
6. If you are using multiple devices, you must configure one device as the clock and trigger master, as follows:
  - a. Click the Row Selector button for the device that you want to be the clock and trigger master.
  - b. For the clock and trigger master device, check the box under the **Master** column.

---

**Note:** Only one device can be the clock and trigger master. If you are using a single device, the application automatically configures the device as the master.

The DT9838 devices support that capability of synchronizing up to four devices. If you are using more than one of these devices, ensure that you connect the devices together using network cables and the Synchronization (RJ45) connector on each device. Then, configure one device as the master and the other devices as slaves. The software automatically drives out the appropriate clock and trigger signals. Refer to [page 112](#) for more information on synchronizing devices.

---

7. (Optional) If you want to remove a device from list of selected devices, click the Row Selector button for the device, and then click **Remove**.
8. Once you have added all the devices that you want to use with the application, click **OK**. *The latest state is saved and used when the application is next run, and the interface of the QuickDAQ is displayed.*

The screenshot displays the QuickDAQ 2014 software interface, which is divided into several functional panels:

- Recording Configuration (Left Panel):**
  - Filename generation:** Includes a dropdown for 'Filename: Sequence' and a 'Start #' field set to 1.
  - Filename Base:** Shows the path 'QuickDAQ Data' with a file extension of '.hpf'.
  - Acquisition Duration:** Set to '00:00:10' (dd:hh:mm:ss).
  - X Axis Span:** Also set to '00:00:10' (dd:hh:mm:ss).
  - Notes:** A section for recording notes, currently empty.
  - Acquisition info:** Displays 'Sample rate: 1000 Hz', 'Sample interval: .001 Sec', and 'Number of scans: 10000'.
- Plot and Data Config (Middle Panel):**
  - Channel List:** A table with columns for Channel Name, Visible, Sample, Visible, Show, Plot, and Signal Group. The entry 'DT9838(00)' is selected.
  - Actions:** Includes 'Channel Plot' and 'Channel Display' buttons.
  - Control / Style:**
    - Plotting performance:** 'Plot update rate' is set to 1 update per second. Options for 'Smooth scrolling' and 'Disable plotting during acquisition' are present.
    - Time domain X axis units:** Radio buttons for 'Sample number', 'Relative time' (selected), and 'Absolute time'. A '24 Hour' / '12 Hour' selector and a 'Display Day' checkbox are also visible.
    - Plot height:** A slider control.
- Channel Plot / Channel Display (Right Panel):**
  - Plot Area:** A graph titled 'Test Data' with a vertical axis (Y-axis) ranging from -1000.00 to 1000.00 and a horizontal axis (X-axis) ranging from 00.0000 to 00.09.0000. The plot area is currently empty, showing only a grid.
  - Acquisition Status (Bottom Right):** Shows the status as 'Idle'.

## Measure Strain Gage Data

The following steps describe how to use the QuickDAQ application to configure a strain gage measurement.

This example uses a full-bridge strain gage (full-bridge bending configuration) connected to a DT9838 module to measure strain.

### Configure the Channels

Configure the channels as follows:

1. Ensure that the strain gage is connected to your data acquisition device.  
*In this example, the strain gage is connected to analog input channel 0 of the DT9838. Refer to [Figure 30 on page 58](#) for the wiring diagram used for a full-bridge bending configuration.*
2. Configure each analog input channel by clicking the **Input Channel Configuration** toolbar button (  ) or by clicking the **Configuration** menu and clicking **Input Channel Configuration**.
3. Enable analog input channel 0 by clicking the **Enable** checkbox for analog input channel 0.

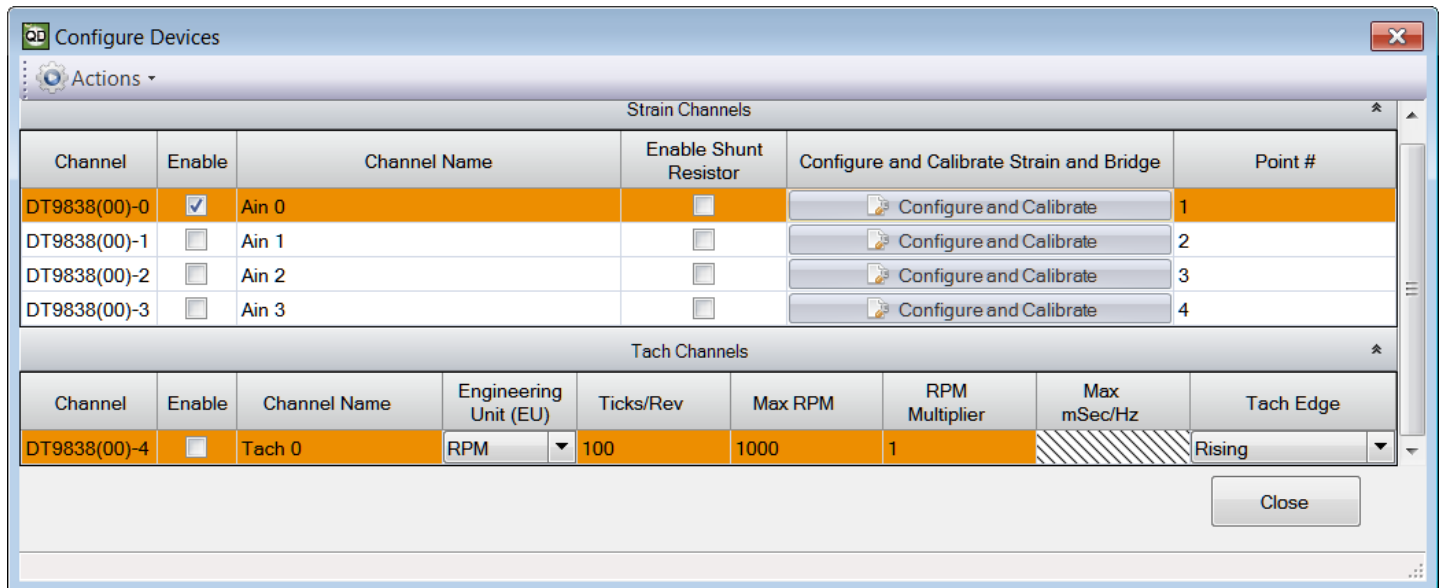

4. In the **Channel Name** column, enter **Full Bridge Bending** for the name of analog input channel 0.
5. In the **Enable Shunt Resistor** column, leave the checkbox unchecked; this disables the shunt resistor.
6. Click the **Configure and Calibrate** button.  
*The following wizard appears:*

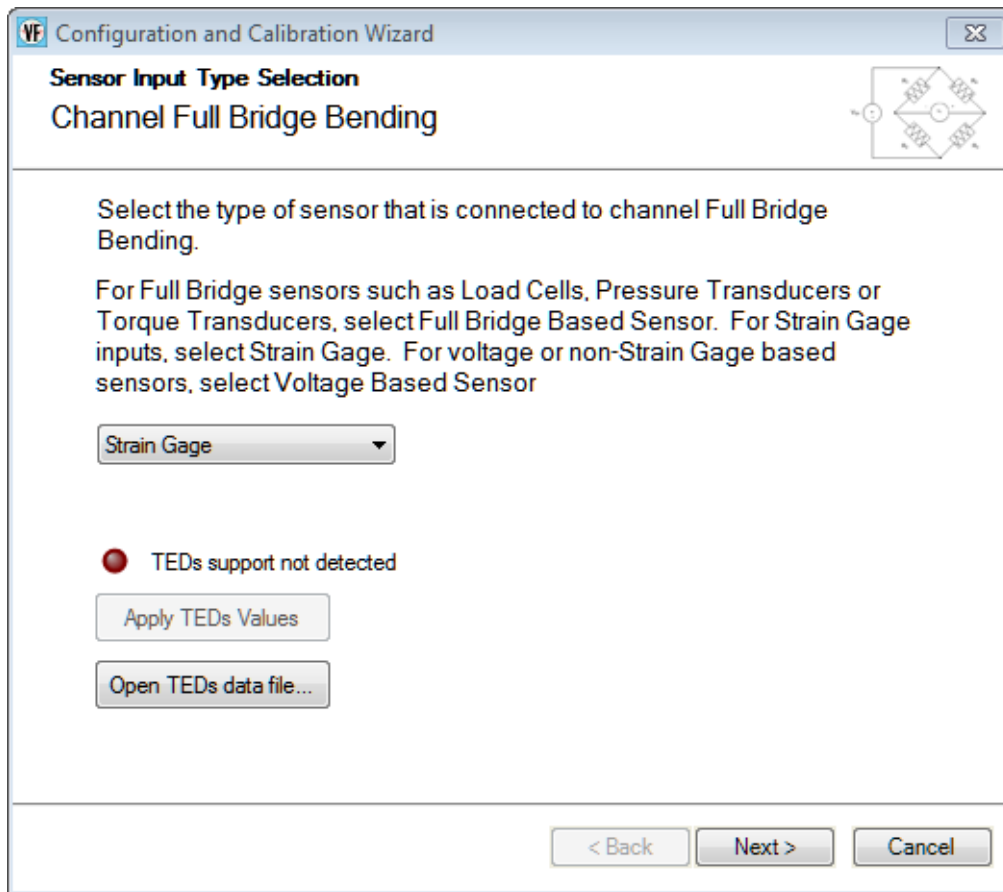

7. Select **Strain Gage**, and click **Next**. (Note that TEDS is not supported for this sensor; therefore, you do not need to click the **Open TEDS data file...** button.)  
*A screen similar to the following appears:*

Configuration and Calibration Wizard

### Strain Gage Configuration

#### Channel Full Bridge Bending

Bridge Type: **Full Bridge Bending**      Excitation Voltage: **5**      Note: This value will be set for all channels.

Nominal Gage: **350** Ohms      Using Sense Lines: **No**      Min Range: **-1000**  $\mu$ Strain      Unit:  **$\mu$ Strain**

Gage Factor: **2**      Lead Wire Resistance: **0.1** Ohms      Max Range: **1000**  $\mu$ Strain      Poisson Ratio: **0.32** ?

< Back      Next >      Cancel

8. For the **Bridge Type** field, select the bridge configuration of your strain gage.  
*In this example, the **Full Bridge Bending** bridge configuration is used.*
9. For the **Excitation Voltage** field, enter the excitation voltage value for your strain gage.  
*In this example, **5 V** is used as the excitation voltage value.*
10. For the **Nominal Gage** field, enter the nominal gage resistance, in ohms, for your strain gage as determined by the manufacturer.  
*In this example, **350** is used as the nominal gage resistance.*
11. For the **Gage Factor** field, enter the gage factor for your strain gage as determined by the manufacturer.  
*In this example, **2** is used as the gage factor.*
12. For the **Using Sense Lines** field, select **Yes** if you are using remote sense lines in your wiring, or **No** if you are not using remote sensing in your wiring.  
*In this example, remote sensing is not used.*
13. For the **Lead Wire Resistance** field, enter the lead wire resistance, in ohms, for your strain gage.  
*In this example, **0.1** is used as the lead wire resistance.*
14. For the **Min Range** field, enter the minimum value of the range for your strain gage.  
*In this example, **-1000** is used as the minimum strain value.*

15. For the **Max Range** field, enter the maximum value of the range for your strain gage.  
*In this example, 1000 is used as the maximum strain value.*
16. For the **Units** field, select the engineering units for the strain gage.  
*In this example,  $\mu$ Strain is used.*
17. In the **Poisson Ratio** column, enter the Poisson ratio for your strain gage.  
*In this example, the Poisson ratio is not used.*
18. Click **Next**.  
*A screen similar to the following appears:*

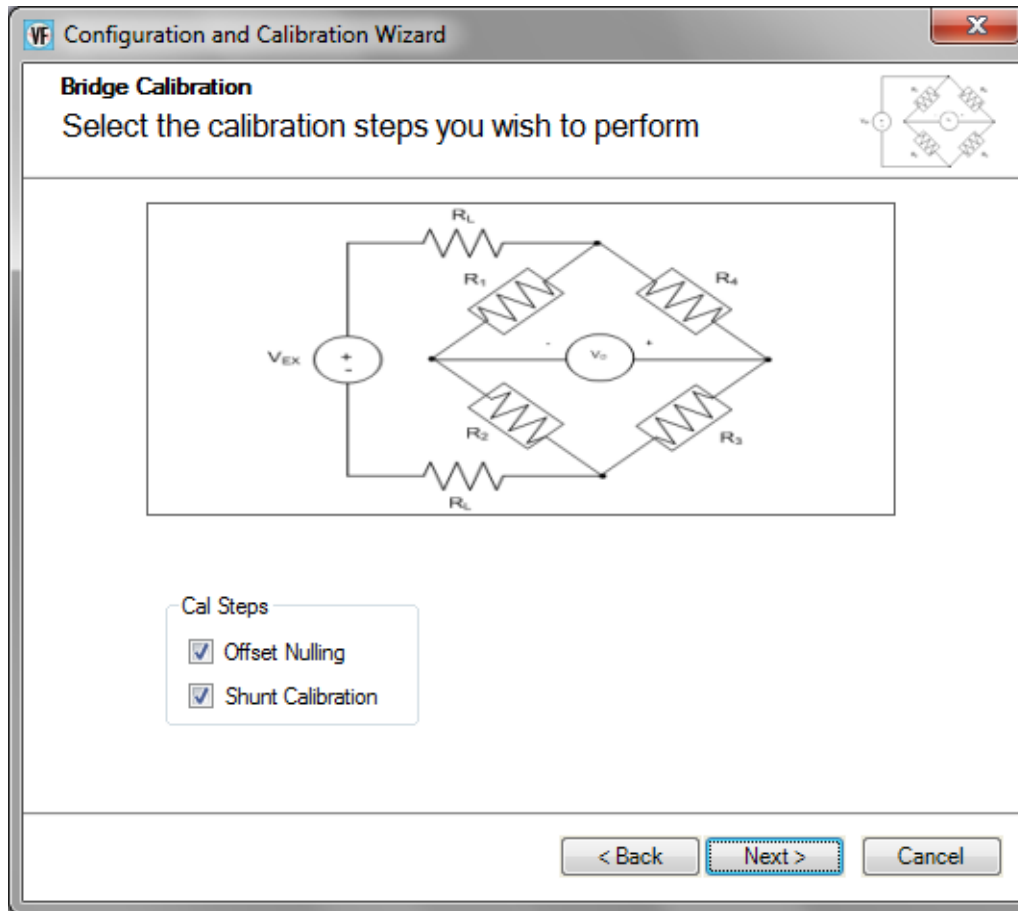

19. Select the calibration steps to perform.  
*In this example, **Offset Nulling** and **Shunt Calibration** are selected.*
20. Click **Next**.  
*A screen similar to the following appears:*

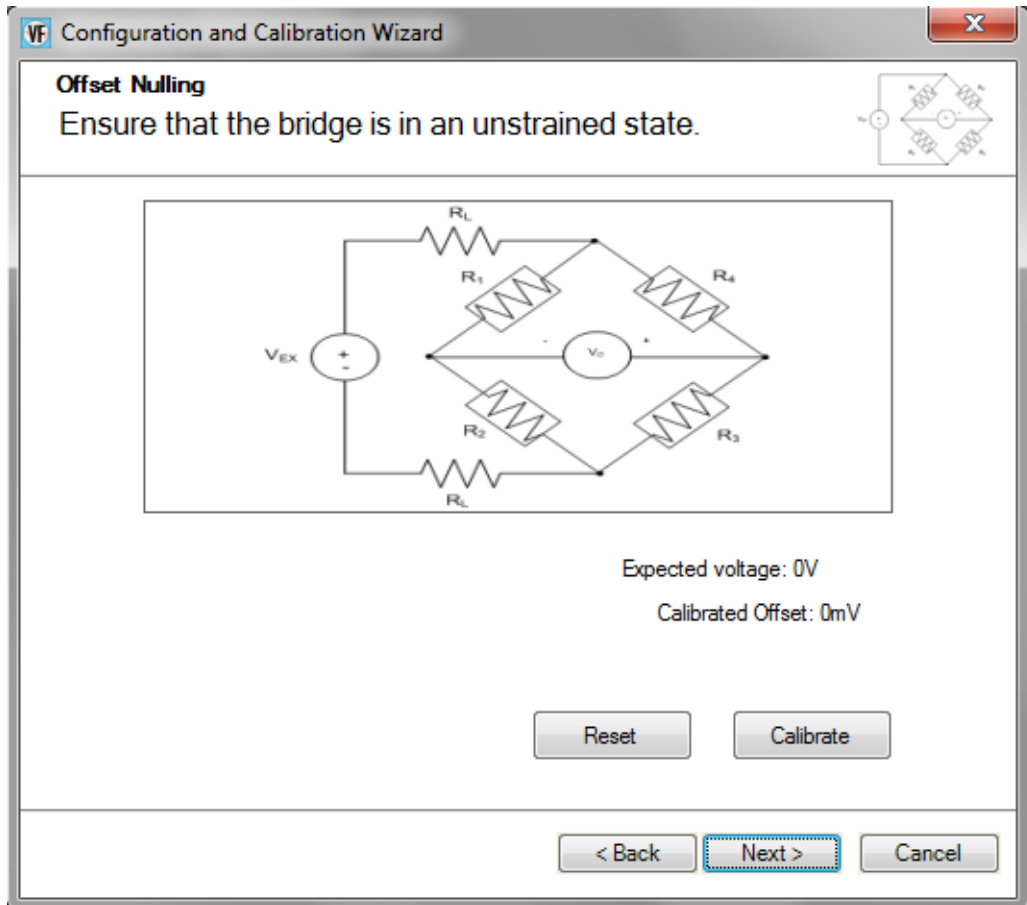

21. Ensure that the bridge is in the unstrained state, and click the **Calibrate** button to perform offset nulling procedure.  
*The expected voltage is shown along with the calibrated offset voltage.*



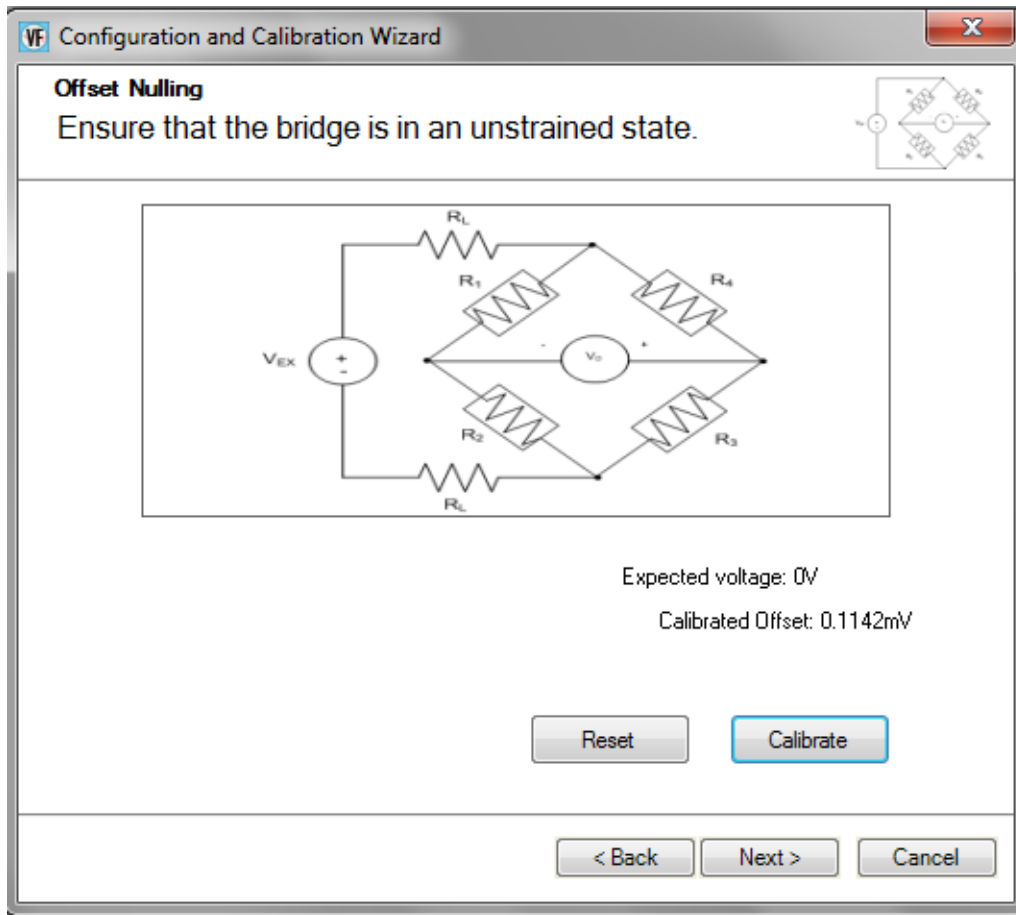

22. Click **Next**.

*A screen similar to the following appears:*

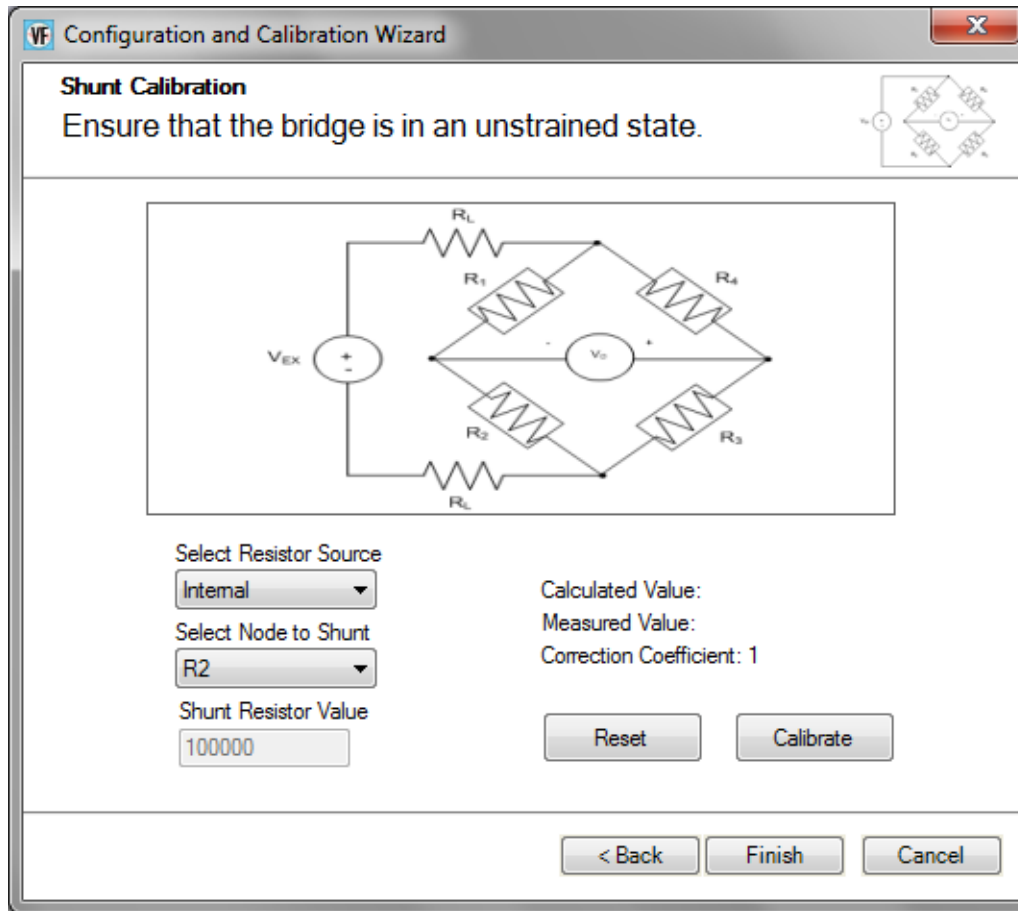

23. For the **Select Resistor Source** field, select **Internal** if you are using the internal shunt resistor provided on the DT9838 module to perform shunt calibration, or **External** if you are using your own external resistor to perform shunt calibration.  
*In this example, **Internal** is used.*
24. For the **Select Node to Shunt** field, select the resistive node or element to which to apply the shunt resistor.  
*In this example, **R2** is used.*
25. Click **Calibrate** to perform the shunt calibration procedure.  
*The calculated value is displayed along with the measured value and correction coefficient.*

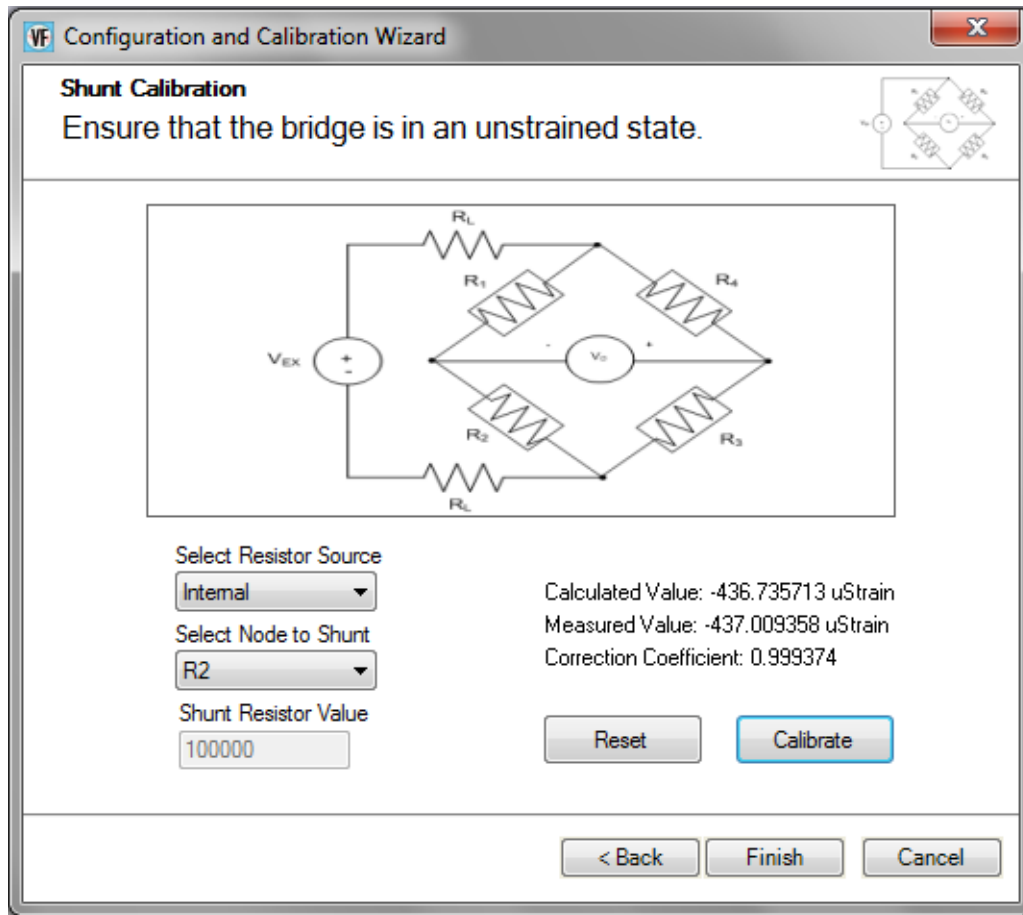

26. Click **Finish**.
27. If desired, enter a test point number under the **Point #** column.  
*In this example, 1 is used.*
28. Click **Close** to close the **Configure Devices** dialog box.

## Configure the Recording Settings

For this example, configure the recording settings as follows:

1. Click the **Recording** tab of the Acquisition Config window.

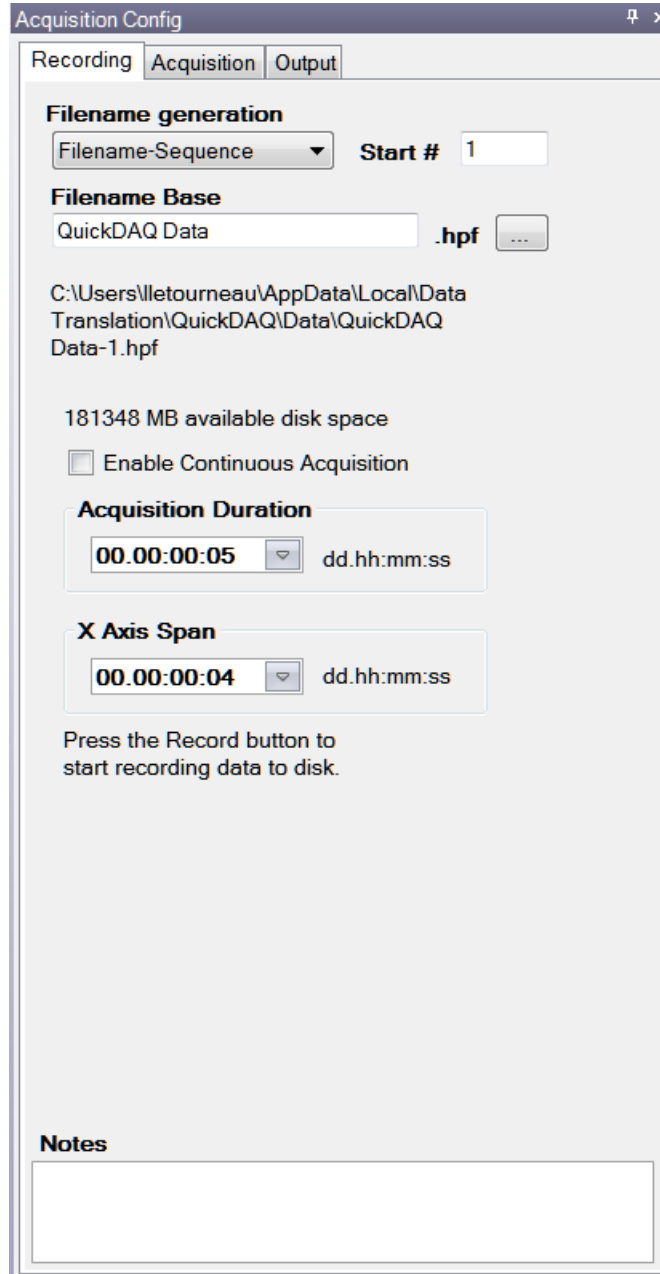

2. For **Filename generation**, use the default **Filename** option.
3. For **Filename**, use the default name for the data file.
4. Leave the **Enable Continuous Acquisition** checkbox unchecked.

5. For **Acquisition Duration**, enter **5 seconds**.  
*The number of seconds for the total run and the amount of available disk space are shown.*
6. For **X Span Axis**, enter **5 seconds**.

## Configure the Acquisition Settings

For this example, configure the acquisition settings as follows:

1. Click the **Acquisition** tab of the Acquisition Config window.

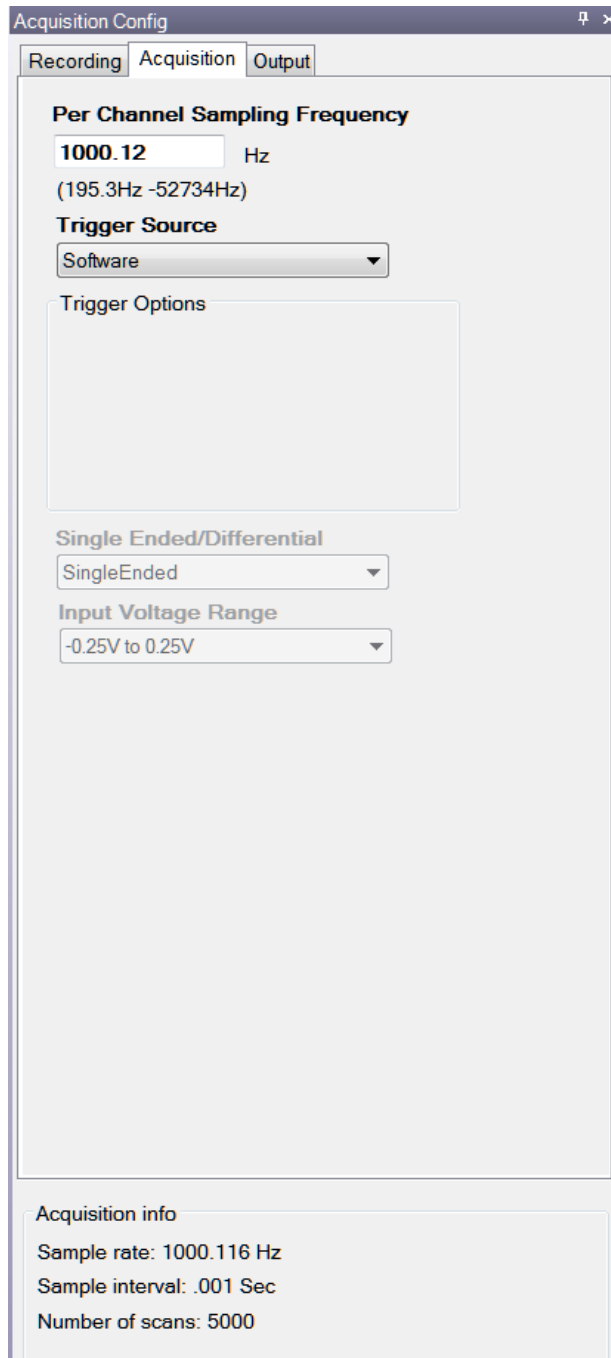

2. For the **Per Channel Sampling Frequency** text box, enter **1000**.  
*The sampling rate, sample interval, and number of scans are displayed.*
3. For the **Trigger Source** check box, select **Software** to ensure that the measurement starts as soon as the **Record** button is clicked.

## Start the Operation

Once you have configured the channels, start acquisition and log data to disk by clicking the **Record** toolbar button (  ).

*Results similar to the following are displayed in the Channel Plot window.*

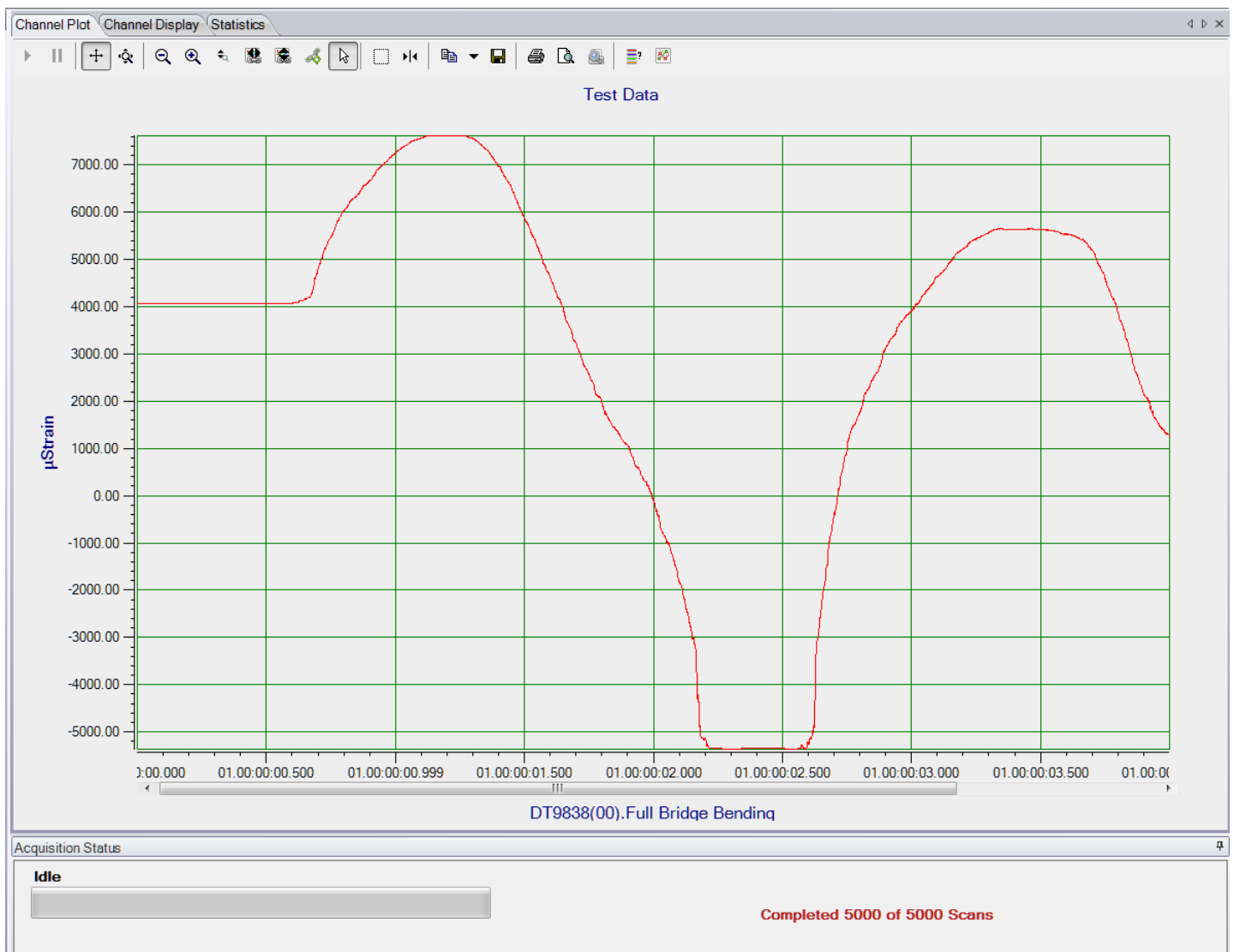

---

**Note:** Many additional options are provided in QuickDAQ for measuring and analyzing the data. Refer to the *QuickDAQ User's Manual* for detailed information.

---

# ***Part 2: Using Your Module***







## ***Principles of Operation***

Analog Input Features .....	91
Tachometer Input Features .....	110
Synchronizing Acquisition on Multiple Modules .....	112

Figure 43 shows a block diagram of the DT9838 module.

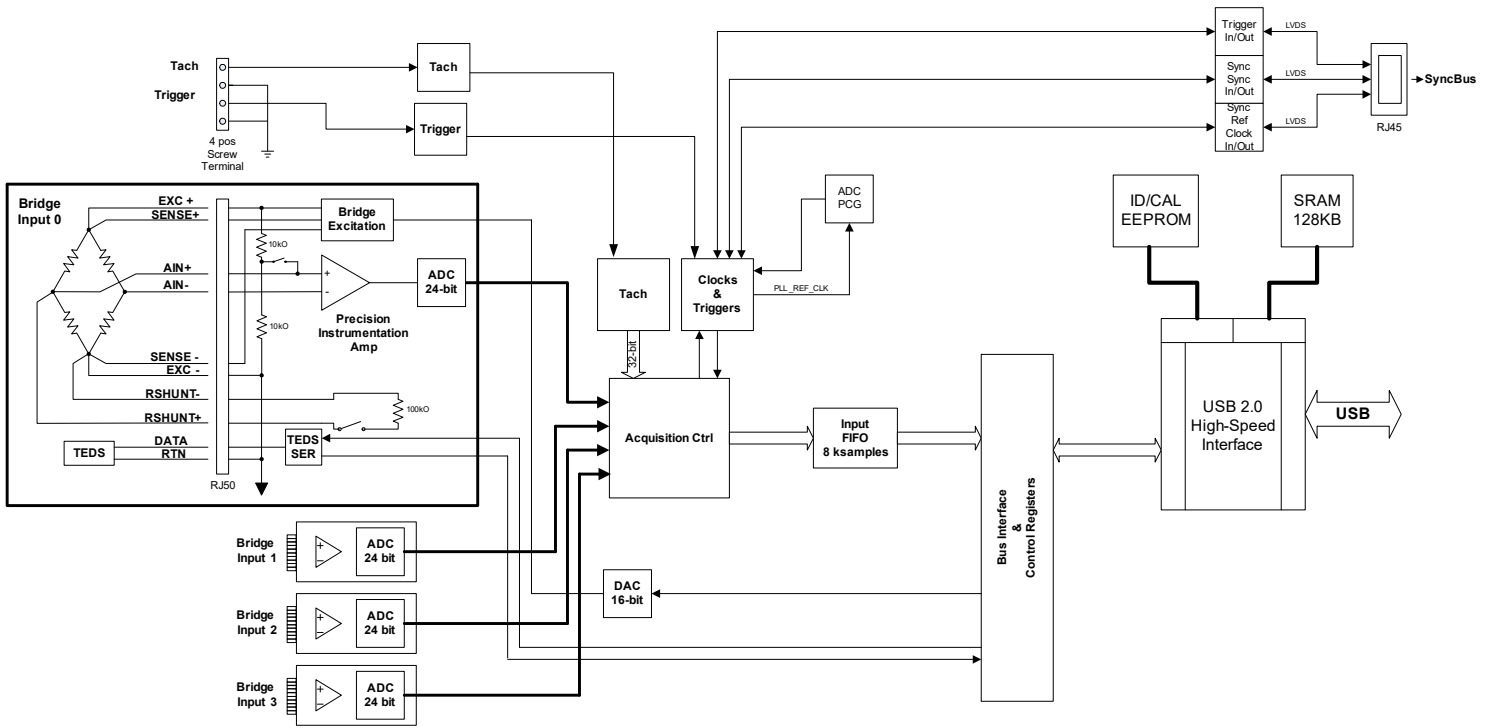

Figure 43: Block Diagram of the DT9838 Module

## Analog Input Features

This section describes the following features of the analog input (A/D) subsystem on the DT9838 module:

- Analog input channels, described on this page
- Bridge configurations, described on [page 92](#)
- Transducer support, described on [page 99](#)
- Bridge excitation, described on [page 100](#)
- Remote sensing and lead wire correction, described on [page 100](#)
- Shunt calibration, described on [page 101](#)
- TEDS, described on [page 103](#)
- Input resolution, described on [page 104](#)
- Input ranges and gains, described on [page 104](#)
- Sample clock sources, described on [page 104](#)
- Conversion modes, described on [page 105](#)
- Triggers, described on [page 107](#)
- Data format, described on [page 109](#)
- Error conditions, described on [page 109](#)

### Analog Input Channels

The DT9838 module supports four, simultaneous, analog input channels that accept bridge sensors through RJ50 connectors on the module.

You can acquire data from a single analog input channel or from a group of analog input channels on the module. Analog input channels are numbered 0 to 3.

The following subsections describe how to specify the channels.

#### ***Specifying a Single Analog Input Channel***

The simplest way to acquire data from a single analog input channel is to specify the channel for a single-value analog input operation using software; refer to [page 105](#) for more information about single-value operations.

#### ***Specifying One or More Analog Input Channels***

You can read data from one or more analog input channels by specifying the channel (0 to 3) in the analog input channel list.

The DT9838 module also allows you to read the value of the tachometer input in the analog input data stream. This feature is particularly useful when you want to correlate the analog input measurements with tachometer data. Refer to [page 110](#) for more information about the tachometer input channel.

Using software, specify the channels that you want to sample. For the DT9838, you can enter up to five entries in the analog channel list, including the analog input channels (0 to 3) and the tachometer input (channel 4).

Because this module features simultaneous sampling, the order of the channels in the channel list does not matter. You cannot specify the same channel more than once in the list.

## Bridge Configurations

All strain gage configurations are based on the concept of a Wheatstone bridge. A Wheatstone bridge is a network of four resistive legs, or nodes. One or more of these nodes can be active sensing element. [Figure 44](#) shows a basic circuit diagram of a Wheatstone bridge.

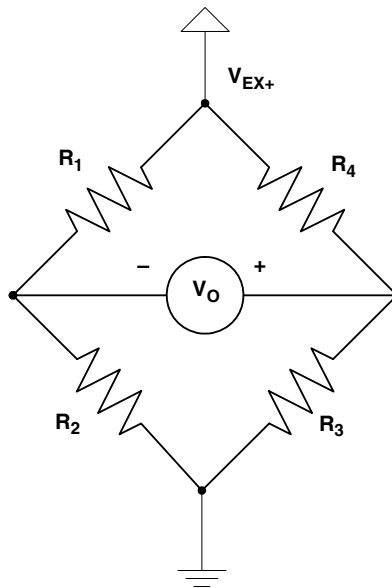

**Figure 44: Wheatstone Bridge Circuit Diagram**

The Wheatstone bridge is the electrical equivalent of two parallel voltage divider circuits.  $R_1$  and  $R_2$  comprise one voltage divider circuit, and  $R_4$  and  $R_3$  comprise the second voltage divider circuit. The output of a Wheatstone bridge is measured between the middle nodes of the two voltage dividers ( $V_O$ ).

Physical phenomena, such as a change in strain applied to a specimen or a temperature shift, changes the resistance of the active sensing elements in the Wheatstone bridge. The Wheatstone bridge configuration is used to help measure the small variations in resistance that the sensing elements produce corresponding to a physical change in the specimen.

A strain gage is a collection of all the active elements of a Wheatstone bridge. You use different bridge configurations for different tasks. For each analog input channel, the DT9838 module supports the following bridge configurations to measure axial and/or bending strain:

- Quarter-Bridge
- Quarter-Bridge Temp Comp
- Half-Bridge Poisson
- Half-Bridge Bending
- Full-Bridge Bending
- Full-Bridge Bending Poisson
- Full-Bridge Axial Poisson

---

**Note:** If you do not wish to use a bridge, you can also configure the channel for a voltage measurement.

---

You specify the bridge configuration in software. The bridge configuration that you select determines the way you wire the sensor elements to the channel. Refer to [Chapter 3](#) starting on [page 35](#) for more information on how to wire these bridge configurations to the DT9838 module.

Measured strain is determined by referencing the acquired data when the bridge is in the strained condition to the acquired data when the bridge is in an unstrained condition. The difference in measurements is then applied to the appropriate strain transfer function for the particular bridge configuration, which yields a value of strain in units of strain or microstrain. This transfer function can be modified by including corrections for lead wire resistance and/or shunt calibration.

The following sections provide the circuit diagram for each of the supported bridge configurations as well as the bridge transfer function that the DT9838 uses to convert voltage to strain for each configuration. The following terms are used in this section:

- $\varepsilon$  is the measured strain (+ $\varepsilon$  is the tensile strain and  $-\varepsilon$  is the compressive strain).
- GF is the gage factor, which is specified by the gage manufacturer. You specify this value in software for each bridge (analog input channel).
- $R_g$  is the nominal gage resistance, which is specified by the gage manufacturer. You specify this value in software for each bridge (analog input channel).
- $R_L$  is the lead wire resistance. You specify this value in software for each bridge (analog input channel).
- $\nu$  is the Poisson ratio, defined as the negative ratio of transverse strain to axial (longitudinal) strain. You specify this value in software for each bridge (analog input channel).
- $V_{EX}$  is the excitation voltage. You specify this value in software. Refer to [page 100](#) for more information on the excitation voltage.
- $V_u$  is the initial, unstrained voltage output.

- $V_s$  is the measured voltage output when strained.
- $V_r$  is the voltage ratio that is used in the voltage-to-strain conversion equations and is defined by the following equation:

$$V_r = \frac{V_S - V_u}{V_{EX}}$$

### Quarter-Bridge Configuration

Figure 45 shows the circuit diagram that the DT9838 uses for a 3-wire Quarter-Bridge configuration.

**Note:** This configuration is used with rectangular and delta rosettes. Tee rosettes are not supported. Refer to [page 42](#) for more information on rosettes.

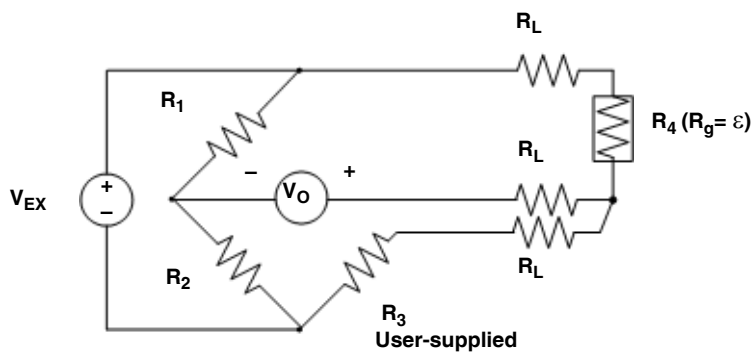

In this diagram:

$R_1$  and  $R_2$  are half-bridge completion resistors that are provided by the DT9838.

$R_3$  is the quarter-bridge completion resistor that you must supply.

$R_4$  is the active strain-gage element that measures the tensile strain ( $R_g = +\epsilon$ ).

Figure 45: Quarter-Bridge Circuit Diagram

For a 3-wire Quarter-Bridge configuration, the following bridge transfer function is used to convert voltage to strain when lead wire correction and shunt calibration are not used:

$$\text{Strain}(\epsilon) = \frac{-4V_r}{GF(1 + 2V_r)}$$

Refer to [page 100](#) for more information on lead wire resistance; refer to [page 101](#) for more information on shunt calibration.

Refer to [page 42](#) for information on wiring a Quarter-Bridge configuration to the DT9838.

## Quarter-Bridge Temp Comp Configuration

Figure 46 shows the circuit diagram that the DT9838 uses for the Quarter-Bridge Temp Comp configuration. This circuit diagram (and bridge transfer function) is also used for a Quarter-Bridge configuration where the user places a resistor at the strain gage.

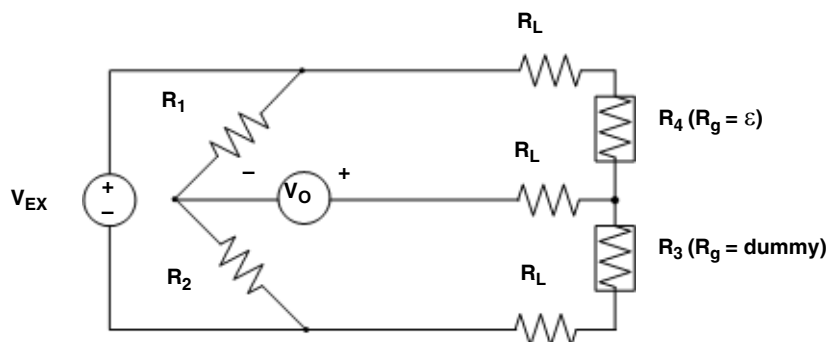

In this diagram:

$R_1$  and  $R_2$  are half-bridge completion resistors that are provided by the DT9838.

$R_4$  is an active strain-gage element that measures axial or bending strain in the principal direction of strain ( $R_g = +\varepsilon$ ).

$R_3$  is a dummy strain gage element ( $R_g = \text{dummy}$ ) that has the same nominal resistance and temperature coefficient as  $R_4$ .

Figure 46: Quarter-Bridge Temp Comp Circuit Diagram

For the Quarter-Bridge Temp Comp configuration, the following bridge transfer function is used to convert voltage to strain when lead wire correction and shunt calibration are not used:

$$\text{Strain}(\varepsilon) = \frac{-4V_r}{GF(1 + 2V_r)}$$

Refer to [page 100](#) for more information on lead wire resistance; refer to [page 101](#) for more information on shunt calibration.

Refer to [page 47](#) for information on wiring a Quarter-Bridge Temp Comp configuration to the DT9838.

## Half-Bridge Poisson Configuration

Figure 47 shows the circuit diagram that the DT9838 uses for the Half-Bridge Poisson configuration.

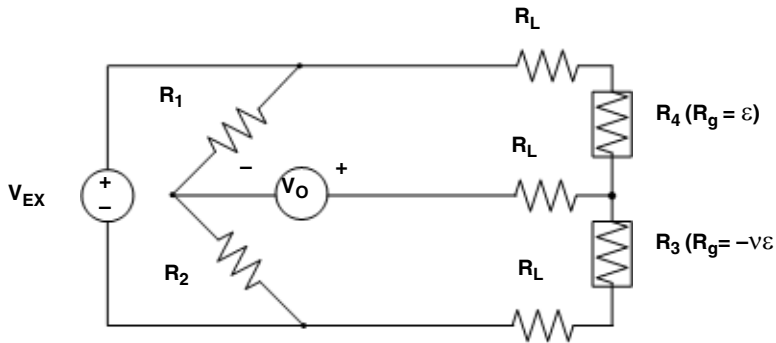

In this diagram:

$R_1$  and  $R_2$  are half-bridge completion resistors that are provided by the DT9838.

$R_4$  is the active strain-gage element that measures strain in the direction of axial or bending strain ( $R_g = +\varepsilon$ ).

$R_3$  is the active strain gage that measures strain in the direction perpendicular to the principal axis of strain ( $R_g = -\nu\varepsilon$ ).

Figure 47: Half-Bridge Poisson Circuit Diagram

For the Half-Bridge Poisson configuration, the following bridge transfer function is used to convert voltage to strain when lead wire correction and shunt calibration are not used:

$$\text{Strain}(\varepsilon) = \frac{-4V_r}{GF[(1 + \nu) - 2V_r(\nu - 1)]}$$

Refer to [page 100](#) for more information on lead wire resistance; refer to [page 101](#) for more information on shunt calibration.

Refer to [page 50](#) for information on wiring a Half-Bridge Poisson configuration to the DT9838.

### Half-Bridge Bending Configuration

[Figure 48](#) shows the circuit diagram that the DT9838 uses for the Half-Bridge Bending configuration.

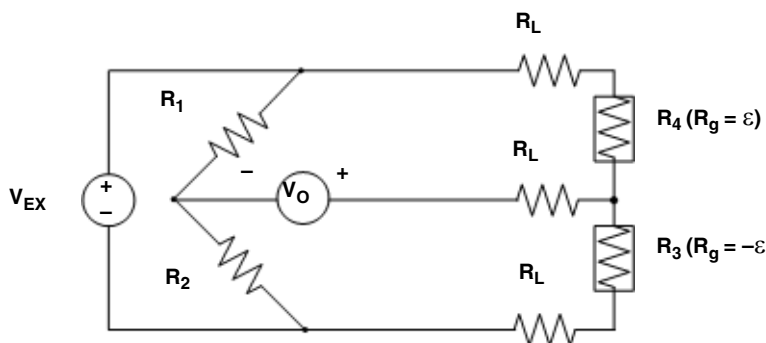

In this diagram:

$R_1$  and  $R_2$  are half-bridge completion resistors that are provided by the DT9838.

$R_3$  ( $R_g = -\varepsilon$ ) and  $R_4$  ( $R_g = +\varepsilon$ ) are both active strain gages mounted in the direction of bending strain but on opposite sides of the specimen.

Figure 48: Half-Bridge Bending Circuit Diagram



For the Half-Bridge Bending configuration, the following bridge transfer function is used to convert voltage to strain when lead wire correction and shunt calibration are not used:

$$Strain(\varepsilon) = \frac{-2V_r}{GF}$$

Refer to [page 100](#) for more information on lead wire resistance; refer to [page 101](#) for more information on shunt calibration.

Refer to [page 54](#) for information on wiring a Half-Bridge Bending configuration to the DT9838.

### Full-Bridge Bending Circuit

[Figure 49](#) shows the circuit diagram that the DT9838 uses for the Full-Bridge Bending configuration.

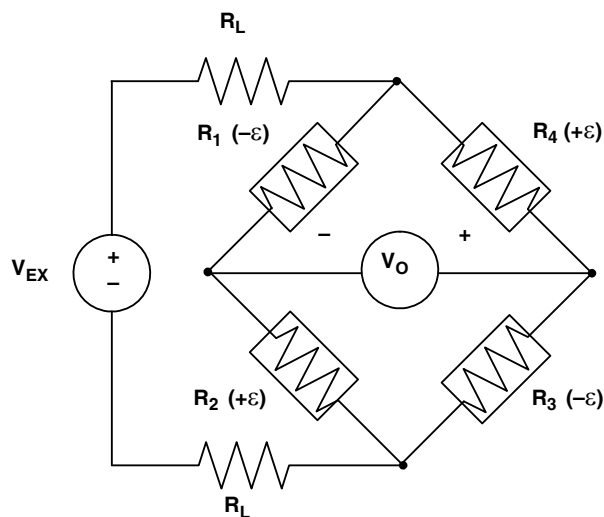

In this diagram:

Four active strain gage elements are used.

$R_1(-\varepsilon)$  and  $R_3(-\varepsilon)$  are mounted in the direction of bending strain on the bottom of the specimen.

$R_2(+\varepsilon)$  and  $R_4(+\varepsilon)$  are mounted in the direction of bending strain on the top of the specimen.

**Figure 49: Full-Bridge Bending Circuit Diagram**

For the Full-Bridge Bending configuration, the following bridge transfer function is used to convert voltage to strain when lead wire correction and shunt calibration are not used:

$$Strain(\varepsilon) = \frac{-V_r}{GF}$$

Refer to [page 100](#) for more information on lead wire resistance; refer to [page 101](#) for more information on shunt calibration.

Refer to [page 57](#) for information on wiring a Full-Bridge Bending configuration to the DT9838.

## Full-Bridge Bending Poisson Configuration

Figure 50 shows the circuit diagram that the DT9838 uses for the Full-Bridge Bending Poisson configuration.

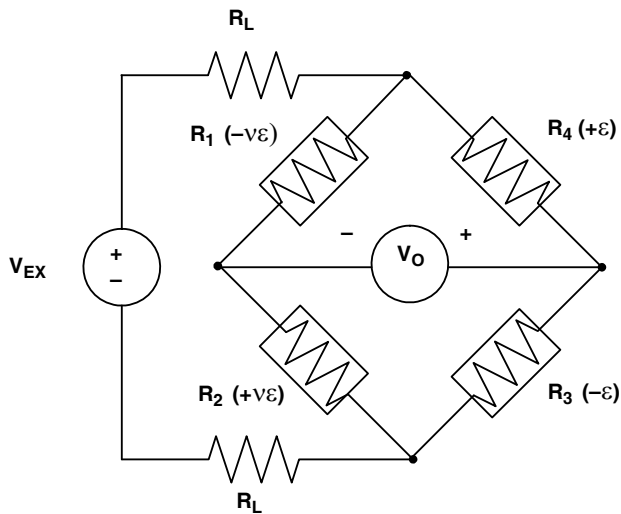

In this diagram:

Four active strain gage elements are used.

$R_3 (-\epsilon)$  and  $R_4 (+\epsilon)$  are mounted in the direction of bending strain with  $R_4$  mounted on the top of the specimen and  $R_3$  mounted on the bottom of the specimen.

$R_1 (-v\epsilon)$  and  $R_2 (+v\epsilon)$  act together as a Poisson gage and are mounted perpendicular to the principal axis of strain with  $R_1$  mounted on the top of the specimen and  $R_2$  mounted on the bottom of the specimen.

Figure 50: Full-Bridge Bending Poisson Circuit Diagram

For the Full-Bridge Bending Poisson configuration, the following bridge transfer function is used to convert voltage to strain when lead wire correction and shunt calibration are not used:

$$\text{Strain}(\epsilon) = \frac{-2V_r}{GF(1 + \nu)}$$

Refer to [page 100](#) for more information on lead wire resistance; refer to [page 101](#) for more information on shunt calibration.

Refer to [page 60](#) for information on wiring a Full-Bridge Bending Poisson configuration to the DT9838.

## Full-Bridge Axial Poisson Configuration

Figure 51 shows the circuit diagram that the DT9838 uses for the Full-Bridge Axial Poisson configuration.

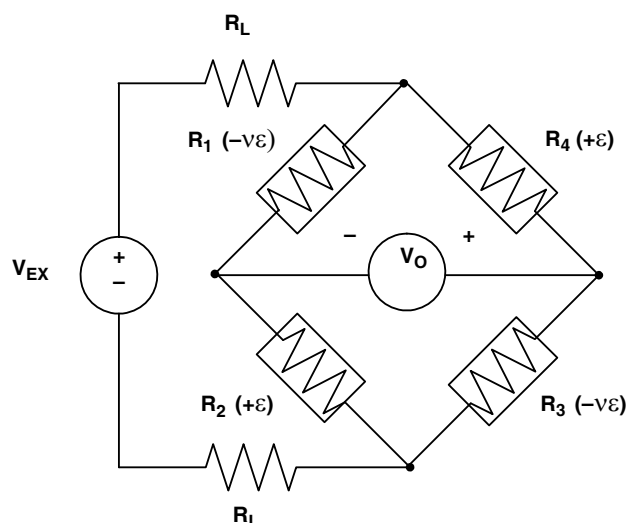

In this diagram:

Four active strain gage elements are used.

$R_2 (+\varepsilon)$  and  $R_4 (+\varepsilon)$  are mounted in the direction of axial strain with  $R_2$  mounted on the top of the specimen and  $R_4$  mounted on the bottom of the specimen.

$R_1 (-v\varepsilon)$  and  $R_3 (-v\varepsilon)$  act together as a Poisson gage and are mounted perpendicular to the principal axis of strain with  $R_1$  mounted on the top of the specimen and  $R_3$  mounted on the bottom of the specimen.

Figure 51: Full-Bridge Axial Poisson Circuit Diagram

For the Full-Bridge Axial Poisson configuration, the following bridge transfer function is used to convert voltage to strain when lead wire correction and shunt calibration are not used:

$$\text{Strain}(\varepsilon) = \frac{-2V_r}{GF[(\nu + 1) - \nu V_r(\nu - 1)]}$$

Refer to [page 100](#) for more information on lead wire resistance; refer to [page 101](#) for more information on shunt calibration.

Refer to [page 63](#) for information on wiring a Full-Bridge Axial Poisson configuration to the DT9838.

## Transducer Support

In addition to strain gages, the DT9838 supports a variety of transducer types, including load cells, pressure transducers, and torque sensors that are based on the Wheatstone bridge.

A load cell, which consists of a number of strain gages, measures load and force by determining the deformation of a structural member as a load or force is applied. Pressure transducers, which consist of strain gages mounted on a diaphragm, measure the deformation of the diaphragm that is proportional to the pressure that is applied. Torque sensors, which consist of strain gages mounted on a torsion bar, measure the shear stress as the torsion bar turns that is proportional to the torque.

To use these transducers, configure the analog input channel for a full-bridge configuration. These transducers typically use 350  $\Omega$  nominal bridge resistance. Refer to [page 66](#) for wiring information.

Instead of supplying a gage factor, use software to enter the sensitivity of the unit provided by the manufacturer of the transducer. For example, a load cell rated for 100 pounds with a 2 mV/V output has a full-scale output of 20 mV when using 10 V of excitation.

Some transducers also support TEDS or virtual TEDS. The DT9838 provides TEDS support to interface to these transducers directly. Refer to [page 103](#) for more information on TEDS.

## Bridge Excitation

Using software, you can program the analog input subsystem on the DT9838 to accept an internal bridge excitation source between 0 VDC and 10 VDC, with better than 1 mV of resolution. The internal bridge excitation circuitry consists of a 16-bit DAC that programs the bridge excitation for all four channels, and a separate bridge drive and sense amplifier for each channel for individual channel regulation. Each channel is also individually current limited to 50 mA.

The DT9838 can be operated on USB power alone; however, you may not be able to use all the channels depending on the bridge resistance and excitation voltage. Alternatively, you can power the DT9838 using an external 5 VDC to 24 VDC power supply. Refer to [Table 1 on page 29](#) for detailed information on the number of channels supported with USB power or external power using various bridge and excitation voltage configurations.

## Remote Sensing and Lead Wire Correction

All bridge types, with the exception of the 3-wire Quarter-Bridge configuration, support the use of remote sense lines (SENSE+ and SENSE-). Refer to [Chapter 3](#) starting on [page 35](#) for connection information. The remote sense lines continuously monitor the voltage that is applied across the bridge at the bridge connection points and null the effects of lead wire resistance by regulating the excitation voltage across a remotely located bridge or half bridge.

If you do not use the remote sense lines to regulate the bridge, the sense lines must still be connected to the excitation lines either at the screw terminal panel or as the lines exit the RJ50 connector (connect SENSE+ to EXC+ and SENSE- to EXC-). You then have the option to correct for lead wire effects in software by entering the value of the lead wire resistance from the DT9838 module to the strain gage. Use the same gage wire for the EXC+ and EXC- lines to ensure that the resistances are matched. Using software, enter the resistance of one line, not the sum of the two lines. The software applies the correction coefficient to the bridge transfer function for the particular channel.

---

**Note:** If the remote sense leads are used, enter a lead wire resistance correction value of 0  $\Omega$ . The module cannot detect whether the remote sense lines have been connected or not, so you must be aware of how the strain gage was wired and determine the appropriate lead wire correction value.

---

The bridge transfer functions that are used to convert voltage to strain when lead wire correction is used are as follows:

- Quarter-Bridge and Quarter-Bridge Temp Comp:

$$\text{Strain}(\varepsilon) = \frac{-4V_r}{GF(1 + 2V_r)} \left(1 + \frac{R_L}{R_g}\right)$$

- Half-Bridge Poisson:

$$\text{Strain}(\varepsilon) = \frac{-4V_r}{GF[(1 + \nu) - 2V_r(\nu - 1)]} \left(1 + \frac{R_L}{R_g}\right)$$

- Half-Bridge Bending:

$$\text{Strain}(\varepsilon) = \frac{-2V_r}{GF} \left(1 + \frac{R_L}{R_g}\right)$$

- Full-Bridge Bending:

$$\text{Strain}(\varepsilon) = \frac{-V_r}{GF} \left(1 + \frac{2R_L}{R_g}\right)$$

- Full-Bridge Bending Poisson:

$$\text{Strain}(\varepsilon) = \frac{-2V_r}{GF(1 + \nu)} \left(1 + \frac{2R_L}{R_g}\right)$$

- Full-Bridge Axial Poisson:

$$\text{Strain}(\varepsilon) = \frac{-2V_r}{GF[(\nu + 1) - V_r(\nu - 1)]} \left(1 + \frac{2R_L}{R_g}\right)$$

## Shunt Calibration

As discussed in [Chapter 3](#) starting on [page 35](#), shunt calibration is another method of compensating for the lead wire resistance in the bridge. It is used to calibrate a configured channel to an artificial amount of strain that is simulated by altering the resistance of one element of the connected bridge.

With the bridge in the unstrained condition, you programmatically shunt one of the elements of the bridge with a known precision resistor value. You can use either your own external resistor or the internal 100 kΩ resistor on the DT9838 module. Using software, you can then read the value of the bridge, compare it to the expected value, and calibrate the channel accordingly.

The following sections describe the bridge transfer functions that the DT9838 uses for each bridge configuration to simulate strain during shunt calibration.

Keep the following definitions in mind as you read these sections:

- $\varepsilon_s$  is a calculated value. It is the expected value of strain with the shunt calibration resistor engaged.
- $R_{SH}$  is the shunt calibration resistance.
- $\varepsilon_{SH}$  is the measured value of strain with a shunt calibration resistor engaged.
- $U$  is a calculated value. It is the expected value of  $V_r$  with a shunt calibration resistor applied to the bridge.

Note that the sign of  $U$  depends on which of the four bridge elements are shunted.

If  $R_1$  or  $R_3$  is shunted,  $U$  is negative and is determined as follows:

$$U = \frac{-R_g}{4R_{sh} + 2R_g}$$

If  $R_2$  or  $R_4$  is shunted,  $U$  is positive and is determined as follows:

$$U = \frac{R_g}{4R_{sh} + 2R_g}$$

### **Shunt Calibration Equation for the Quarter-Bridge and Quarter-Bridge Temp Comp Configurations**

The DT9838 uses the following bridge transfer function when lead wire correction and shunt calibration is used across  $R_3$  or  $R_4$  of the Quarter-Bridge or Quarter-Bridge Temp Comp circuit:

$$Strain(\varepsilon) = \frac{-4V_r}{GF(1 + 2V_r)} \left(1 + \frac{R_L}{R_g}\right) \left(\frac{\varepsilon_s}{\varepsilon_{SH}}\right)$$

### **Shunt Calibration Equation for the Half-Bridge Poisson Configuration**

The DT9838 uses the following bridge transfer function when lead wire correction and shunt calibration is used across  $R_3$  or  $R_4$  of the Half-Bridge Poisson configuration:

$$Strain(\varepsilon) = \frac{-4V_r}{GF[(1 + \nu) - 2V_r(\nu - 1)]} \left(1 + \frac{R_L}{R_g}\right) \left(\frac{\varepsilon_s}{\varepsilon_{SH}}\right)$$

### **Shunt Calibration Equation for the Half-Bridge Bending Configuration**

The DT9838 uses the following bridge transfer function when lead wire correction and shunt calibration is used across  $R_3$  or  $R_4$  of the Half-Bridge Bending configuration:

$$Strain(\varepsilon) = \frac{-2V_r}{GF} \left(1 + \frac{R_L}{R_g}\right) \left(\frac{\varepsilon_s}{\varepsilon_{SH}}\right)$$

### **Shunt Calibration Equation for the Full-Bridge Bending Configuration**

The DT9838 uses the following bridge transfer function when lead wire correction and shunt calibration is used across  $R_1$ ,  $R_2$ ,  $R_3$ , or  $R_4$  of the Full-Bridge Bending configuration:

$$Strain(\varepsilon) = \frac{-V_r}{GF} \left( 1 + \frac{2R_L}{R_g} \right) \left( \frac{\varepsilon_s}{\varepsilon_{SH}} \right)$$

### **Shunt Calibration Equation for the Full-Bridge Bending Poisson Configuration**

The DT9838 uses the following bridge transfer function when lead wire correction and shunt calibration is used across  $R_1$ ,  $R_2$ ,  $R_3$ , or  $R_4$  of the Full-Bridge Bending Poisson configuration:

$$Strain(\varepsilon) = \frac{-2V_r}{GF(1 + \nu)} \left( 1 + \frac{2R_L}{R_g} \right) \left( \frac{\varepsilon_s}{\varepsilon_{SH}} \right)$$

### **Shunt Calibration Equation for the Full-Bridge Axial Poisson Configuration**

The DT9838 uses the following bridge transfer function when lead wire correction and shunt calibration is used across  $R_1$ ,  $R_2$ ,  $R_3$ , or  $R_4$  of the Full-Bridge Axial Poisson configuration:

$$Strain(\varepsilon) = \frac{-2V_r}{GF[(\nu + 1) - V_r(\nu - 1)]} \left( 1 + \frac{2R_L}{R_g} \right) \left( \frac{\varepsilon_s}{\varepsilon_{SH}} \right)$$

## **Offset Nulling**

A balanced bridge under ideal conditions with zero strain applied produces zero volts. In practice, the output of a bridge in an unstrained condition is offset from zero slightly due to imperfect matching of bridge resistances.

It is not necessary to balance a bridge prior to the measurement. Instead, you can use software to make a reference measurement with the bridge in an unstrained condition. All subsequent data is then offset in software by the reference value.

## **TEDS**

Each analog input channel on the DT9838 module provides a Class II TEDS (Transducer Electronic Data Sheet) interface through the RJ50 connector. The interface consists of two-wires (TEDS DATA and TEDS RETURN).

TEDS is supported by some load-cells and other transducers with strain gages. Refer to [page 66](#) for information on wiring TEDS for a load-cell sensor.

## Input Resolution

The value that is measured across the bridge of an analog input channel on the DT9838 module is amplified and applied to the 24-bit Sigma-Delta analog-to-digital converter (ADC). The ADC oversamples the incoming signal, filters the values, and produces a result.

The resolution of the analog input subsystem is fixed at 24 bits.

## Input Range

The default full-scale input range for each channel is  $\pm 250$  mV.

## A/D Sample Clock

The DT9838 module supports an internal clock, which is generated by an internal programmable PLL. Using software, you can program the sample rate from 195.3 Samples/s to 52.734 kSamples/s.

---

**Note:** According to sampling theory (Nyquist Theorem), specify a frequency that is at least twice as fast as the input's highest frequency component. For example, to accurately sample a 20 kHz signal, specify a sampling frequency of at least 40 kHz to avoid aliasing.

The modules support a passband from DC to  $0.453 \times$  sampling frequency, resulting in a maximum signal bandwidth of 23.89 kHz.

---

The actual frequency that the module can achieve may be slightly different than the frequency you specified due to the accuracy of the clock. You can determine the actual clock frequency using software.

Internally, the value that you specify for the internal clock frequency is multiplied by 512 to set the oscillator on the module. For example, if you specify an internal clock frequency of 50 kHz, the module sets the internal oscillator for the A/D converters to 25.6 MHz. The maximum timebase is 27 MHz.

Once the sample clock is started, the module requires 39 clock pulses before the first A/D conversion is completed ( $39/\text{sample rate}$ ) due to the group delay of the converters. The software automatically adjusts for the group delay to provide only valid data in each buffer.

The tachometer data (which does not have the 39 sample group delay) is synchronized with the analog data stream. This is done through the firmware and device driver by caching the tachometer data and aligning it in time with the analog data in the user's data buffers.



## Analog Input Conversion Modes

The DT9838 module supports the following conversion modes:

- Single-value mode, described below
- Continuous scan mode, described on [page 105](#)

### **Single-Value Mode**

Single value operations are the simplest to use. Using software, you specify the analog input channel. The module acquires the data from the specified channel and returns the data immediately. For a single-value operation, you cannot specify a clock source, trigger source, scan mode, or buffer.

Single-value operations stop automatically when finished; you cannot stop a single-value operation.

---

**Note:** You cannot read the value of the tachometer using a standard single-value operation. To read these values, specify the channel as part of the analog input channel list using continuous scan mode, described next.

---

### **Continuous Scan Mode**

Continuous scan mode takes full advantage of the capabilities of the DT9838 module. Use continuous scan mode if you want to accurately control the period between successive simultaneous conversions of all channels in a channel list. You can specify a channel list, clock source, start trigger, reference trigger, post-trigger scan count, and buffer using software.

You can enter up to five entries in the channel list, including the four analog input channels (A/D channels 0 to 3) and the tachometer (A/D channel 4).

When it detects the start trigger, the module samples all the channels in the list simultaneously.

If a reference trigger is not specified, data that is acquired after the start trigger is post-trigger data. The sampled data is placed in the allocated buffer(s). The operation continues until you stop it or until no more buffers are available.

If a reference trigger is specified, data that is acquired after the start trigger is pre-trigger data; when the reference trigger occurs, pre-trigger data acquisition stops and post-trigger acquisition starts at the next sample. The sampled data is placed in the allocated buffer(s). The operation continues until the number of scans that you specify for the post-trigger scan count have been acquired; at the point, the operation stops. Note that the sample at which the trigger occurs is not counted as a post-trigger sample. Refer to [page 107](#) for more information about triggers.

The conversion rate is determined by the frequency of the input sample clock; refer to [page 104](#) for more information about the input sample clock. The sample rate, which is the rate at which a single entry in the channel list is sampled, is the same as the conversion rate due to the simultaneous nature of the module.

Using software, you can stop a scan by performing either an orderly stop or an abrupt stop. In an orderly stop, the module finishes acquiring the current buffer, stops all subsequent acquisition, and transfers the acquired data to host memory; any subsequent triggers are ignored. In an abrupt stop, the module stops acquiring samples immediately; the current buffer is not completely filled, it is returned to the application only partially filled, and any subsequent triggers are ignored.

To select continuous scan mode, use software to specify the following parameters:

- Specify the data flow as Continuous
- Specify the clock source as internal and specify the clock frequency (refer to [page 104](#))
- Specify the start trigger (refer to [page 107](#))
- Specify the reference trigger (refer to [page 108](#))
- Specify the post-trigger scan count (the number of post-trigger samples to acquire after the reference trigger occurs)

[Figure 52](#) illustrates continuous scan mode (using a start and reference trigger) with a channel list of three entries: channel 0 through channel 2. In this example, pre-trigger analog input data is acquired when the start trigger is detected. When the reference trigger occurs, the specified number of post-trigger samples (3, in this example) are acquired.

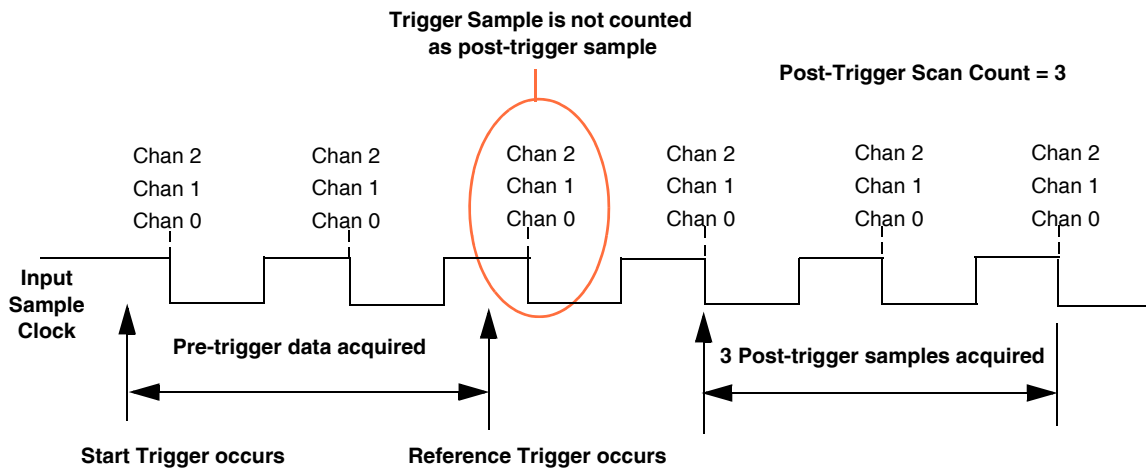

**Figure 52: Continuous Scan Mode**

---

**Note:** The USB LED, shown in [Figure 12 on page 37](#), blinks while the module is acquiring data.

The Trigger LED on the module, shown in [Figure 12 on page 37](#), is amber when the module is waiting for an external digital trigger, threshold trigger, or Sync Bus trigger (the module must have been configured for an external digital trigger, threshold trigger, or Sync Bus trigger), green when the module has been triggered, or off when the module is idle.

---

## Input Triggers

A trigger is an event that occurs based on a specified set of conditions.

On the DT9838 module, you can specify a start trigger source and a reference trigger source. Pre-trigger data acquisition starts when the start trigger event occurs. When the reference trigger event occurs, pre-trigger data acquisition stops and post-trigger acquisition starts. Post-trigger acquisition stops when the number of samples you specify for the post-trigger scan count has been reached. Refer to [page 105](#) for more information.

The Trigger LED on the module, shown in [Figure 12 on page 37](#), is amber when the module is waiting for an external digital trigger or analog threshold trigger (the module must have been configured for an external digital trigger or analog threshold trigger), green when the module has been triggered, or off when the module is idle.

### Start Trigger Sources

The DT9838 module supports the following sources for the start trigger:

- **Software trigger** – A software trigger event occurs when you start the analog input operation (the computer issues a write to the module to begin conversions). Using software, specify the start trigger source as a software trigger.
- **External digital (TTL) trigger** – An external digital (TTL) trigger event occurs when the DT9838 module detects either a rising-edge (positive) or falling-edge (negative) transition on the signal connected to the Ext Trigger pins (pin 3 and 4) of the External Trigger and Tachometer (J6) connector on the module. Using software, specify the start trigger source as an external, positive digital (TTL) trigger or an external, negative digital (TTL) trigger.
- **Threshold trigger** – A threshold trigger event occurs when the signal on a specified analog input channel rises above or falls below a programmable threshold level. Using software, specify the following parameters:
  - Start trigger source – Specify a positive (low-to-high transition) threshold trigger if you want to trigger when the signal rises above a threshold level, or a negative (high-to-low transition) threshold trigger if you want to trigger when the signal falls below a threshold level.
  - Threshold channel – Specify any one of the analog input channels as the threshold input channel.
  - Threshold level – Specify a value between  $-250$  mV and  $+250$  mV as the threshold level.

---

**Note:** If you choose a threshold trigger as both the start trigger and the reference trigger, the threshold channel and threshold level must be the same; otherwise, the threshold channel and threshold level of the reference threshold trigger will be used for both trigger sources. The polarity of the trigger (positive or negative going) can be different for each trigger source.

---

- **Sync Bus trigger** – When multiple DT9838 modules (or multiple DT9838 and DT9837 Series modules) are connected together using the Sync Bus (RJ45) connector, you can use the Sync Bus trigger as the start trigger of the slave module by setting the synchronization mode of module to Slave. In this configuration, any other start trigger for the slave module is ignored. Refer to [page 112](#) for more information on this configuration.

### **Reference Trigger Sources**

The DT9838 module supports the following sources for the reference trigger:

- **External digital (TTL) trigger** – An external digital (TTL) reference trigger event occurs when the DT9838 module detects either a rising-edge (positive) or falling-edge (negative) transition on the signal connected to the Ext Trigger pins (pin 3 and 4) of the External Trigger and Tachometer (J6) connector on the module. Using software, specify the start trigger source as an external, positive digital (TTL) trigger or an external, negative digital (TTL) trigger.
- **Threshold trigger** – A threshold reference trigger event occurs when the signal on a specified analog input channel rises above or falls below a programmable threshold level. Using software, specify the following parameters:
  - Start trigger source – Specify a positive (low-to-high transition) threshold trigger if you want to trigger when the signal rises above a threshold level, or a negative (high-to-low transition) threshold trigger if you want to trigger when the signal falls below a threshold level.
  - Threshold channel – Specify any one of the analog input channels as the threshold input channel.
  - Threshold level – Specify a value between -250 mV and +250 mV as the threshold level.

---

**Note:** If you choose a threshold trigger as both the start trigger and the reference trigger, the threshold channel and threshold level must be the same; otherwise, the threshold channel and threshold level of the reference threshold trigger will be used for both trigger sources. The polarity of the trigger (positive or negative going) can be different for each trigger source.

---

- **Sync Bus trigger** – When multiple DT9838 modules (or multiple DT9838 and DT9837 Series modules) are connected together using the Sync Bus (RJ45) connector, you can set the reference trigger of a slave DT9838 module to Sync Bus if you want to receive a Sync Bus trigger from one of the other modules to stop pre-trigger acquisition and start post-trigger acquisition. Refer to [page 112](#) for more information on this configuration.

## Data Format

The DT9838 module uses offset binary data encoding, where 000000 represents  $-250$  mV and FFFFFFFh represents  $+250$  mV. Use software to specify the data encoding as binary. The ADC outputs FFFFFFFh for above-range signals, and 000000 for below-range signals.

Before you begin acquiring data, you must allocate buffers to hold the data. An event is raised whenever a buffer is filled. This allows you to move and/or process the data as needed.

---

**Note:** We recommend that you allocate a minimum of two buffers that can contain even multiples of 256 samples.

---

Data is written to multiple allocated input buffers continuously in blocks; when no more empty buffers are available, the operation stops. The data is gap-free.

## Error Conditions

DT9838 module reports overrun errors by sending an overrun event to the application program. If this error condition occurs, the module stops acquiring and transferring data to the host computer. To avoid this error, try one or more of the following:

- Reduce the sample rate
- Close any other applications that are running
- Run the program on a faster computer

## Tachometer Input Features

You can connect a tachometer signal with a range of  $\pm 30$  V to pins 1 and 2 of the External Trigger and Tachometer (J6) connector on the DT9838 module. This signal has a maximum frequency of 1 MHz and a minimum pulse width of 0.4  $\mu$ s. The threshold voltage is fixed at +2 V with 0.5 V of hysteresis.

You can measure the frequency or period of the tachometer input signal to calculate the rotation speed for high-level ( $\pm 30$  V) tachometer input signals. An internal 12 MHz counter is used for the measurement, yielding a resolution of 83 ns (1/12 MHz).

You can read the number of counts between two consecutive starting edges of the tachometer input signal by including channel 4 in the analog input channel list. The starting edge is programmable (either rising or falling).

Using software commands, you can specify the following parameters for the tachometer input:

- The starting edge of the tachometer input signal to use for the measurement (rising or falling edge).
- A flag (called Stale) indicating whether or not the data is new. If the Stale flag is set as Used (the default value), the most significant bit (MSB) of the value is set to 0 to indicate new data; reading the value before the measurement is complete returns an MSB of 1. If the Stale flag is set to Not Used, the MSB is always set to 0.

When the operation is started, the internal 12 MHz counter starts incrementing when it detects the first starting edge of the tachometer input and stops incrementing when it detects the next starting edge of the tachometer input. When the measurement is complete, the counter remains idle until it is read. On the next read, either 0 or the current value of the tachometer input (from the previous measurement operation) is returned depending on the module and the tachometer settings, described above, and the next operation is started automatically.

The software automatically synchronizes the value of the tachometer input with the analog input measurements, so that all measurements are correlated in time. The tachometer input is treated like any other channel in the analog input channel list; therefore, all the triggering and conversion modes supported for analog input channels are supported for the tachometer input.

When you read the value of the tachometer input as part of the analog input data stream, you might see results similar to the following:

**Table 4: An Example of Reading the Tachometer Input as Part of the Analog Input Data Stream**

Time	A/D Value	Tachometer Input Value	Status of Operation
10	5002	0	Operation started, but is not complete
20	5004	0	Operation not complete
30	5003	0	Operation not complete
40	5002	12373	Operation complete
50	5000	12373	Next operation started, but is not complete
60	5002	12373	Operation not complete
70	5004	12373	Operation not complete
80	5003	14503	Operation complete
90	5002	14503	Next operation started, but is not complete

Using the count that is returned from the tachometer input, you can determine the following:

- Frequency of a signal pulse (the number of periods per second). You can calculate the frequency as follows:
  - $\text{Frequency} = 12 \text{ MHz} / (\text{Number of counts} - 1)$   
where 12 MHz is the internal counter/timer clock frequency

For example, if the count is 21, the measured frequency is 600 kHz (12 MHz/20).
- Period of a signal pulse. You can calculate the period as follows:
  - $\text{Period} = 1 / \text{Frequency}$
  - $\text{Period} = (\text{Number of counts} - 1) / 12 \text{ MHz}$   
where 12 MHz is the internal counter/timer clock frequency

## Synchronizing Acquisition on Multiple Modules

DT9838 modules provide a Sync Bus (RJ45) connector that you can use to connect and synchronize multiple DT9838 modules.

---

**Note:** Note that you can also connect DT9837A, DT9837B, and/or DT9837C modules to the DT9838 module in this configuration. Refer to the *DT9837 Series User's Manual* for more information.

---

In this scheme, one module is the master and the other modules are the slave. You specify the synchronization mode (master, slave, or none) of the A/D subsystem using software.

When configured as a master, the Sync Bus connector outputs trigger and clock signals. When configured as a slave, the Sync Bus connector accepts trigger and clock signals from the master; the start trigger source on the slave module is ignored in this configuration since the Sync Bus is used as the start trigger. When configured as none (the default mode), the DT9838 module uses the USB clock instead of the Sync Bus connector. The synchronization mode remains set until changed or until the application exits.

You can connect multiple modules in one of two ways. [Figure 53](#) shows how to connect a maximum of two DT9838 modules by daisy chaining them together through the Sync Bus connector. [Figure 54](#) shows how to connect a maximum of four DT9838 modules by using an RJ45 distribution panel, such as the EP386, where the panel contains four RJ45 connectors that are wired in parallel.

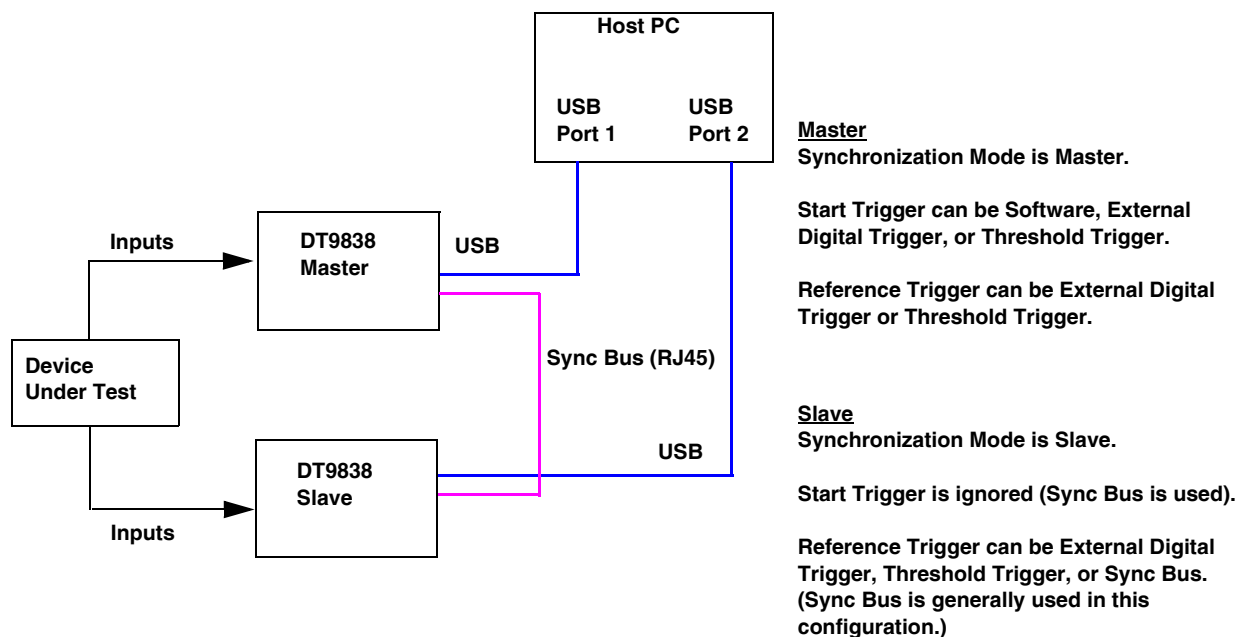

**Figure 53: Synchronizing Two DT9838 Modules by Daisy Chaining the Sync Bus Connectors**



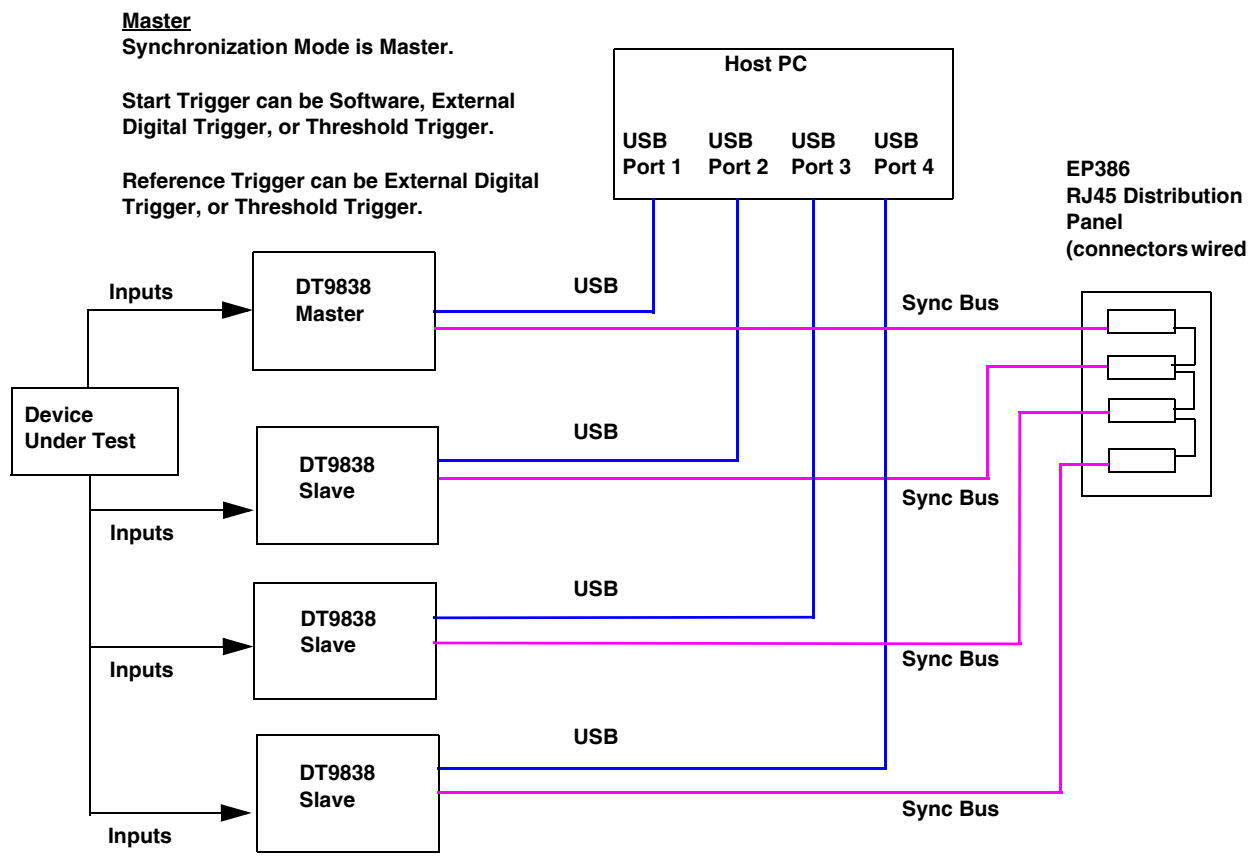

**Slave**  
Synchronization Mode is Slave.

Start Trigger is ignored (Sync Bus is used).

Reference Trigger can be External Digital Trigger, Threshold Trigger, or Sync Bus. (Sync Bus is generally used in this

\* The RJ45 cables must be less than 1 foot in length. For minimum clock skew, the master module must be less than 4 inches away from the RJ45 distribution panel.

**Figure 54: Synchronizing Four DT9838 Modules Using the EP386 RJ45 Distribution Panel (Shown Using an External Trigger)**

When synchronizing multiple modules, start the slave modules before starting the master module. When the master DT9838 module is triggered (using the software trigger, external digital trigger, or threshold trigger), both the master and the slave modules start acquiring data at the same time (within one A/D conversion of the clock). Note that you can set the clock rate to be the same or different on each module.

**Note:** It is important that you start the slave modules first, followed by the master module so that the slave receives the appropriate clock and trigger signals from the master.

If you start the master module before the slaves, the slaves never start; you will see a delay of approximately 20 seconds if you try to stop or abort the analog input operation on a slave module that is waiting for a trigger.

When you stop the master module, the slaves continue to run and return data until you stop the analog input subsystem on the slave modules. Be sure to stop the analog input subsystems on all slave modules before disconnecting the cable from the Sync Bus connectors.

## Triggering DT9838 and DT9837 Series Modules Using the Sync Bus

If you are connecting the DT9838 module to a DT9837 Series module using the Sync Bus trigger, be aware of triggering limitations.

The DT9837 Series supports the following start trigger sources: software, external digital trigger, and threshold trigger. For the reference trigger, the DT9837 Series supports only the threshold trigger source. When configured as a slave, the DT9837 processes a single Sync Bus trigger; the Sync Bus trigger is considered the start trigger and is received and/or driven out as such.

Consider the case where the DT9838 is the master and a DT9837 Series module is the slave, as shown in [Figure 55](#).

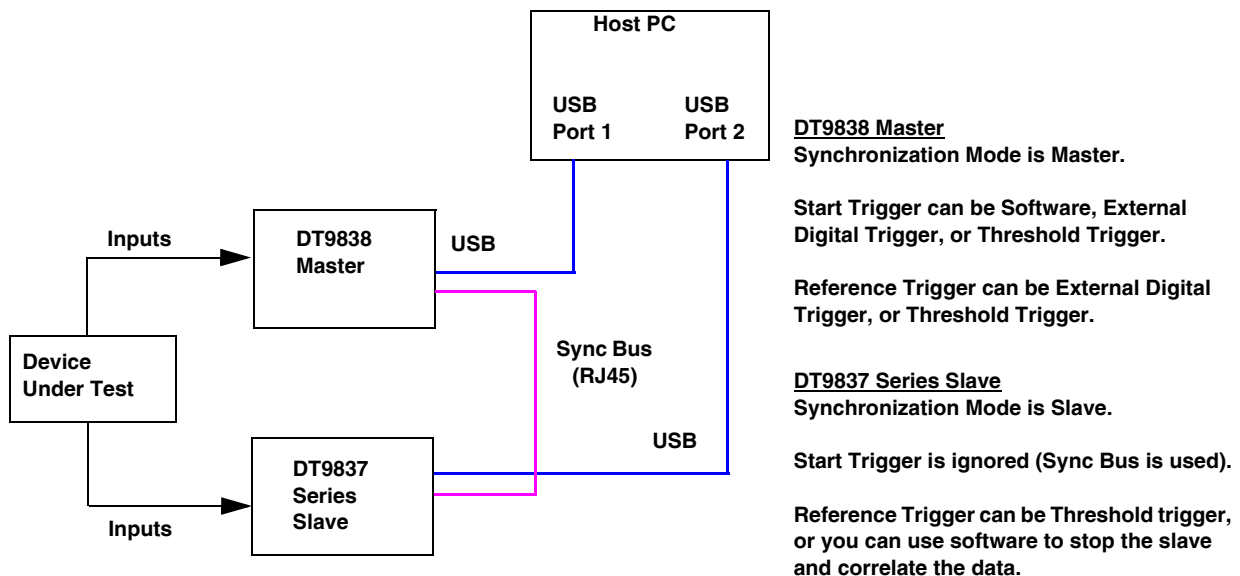
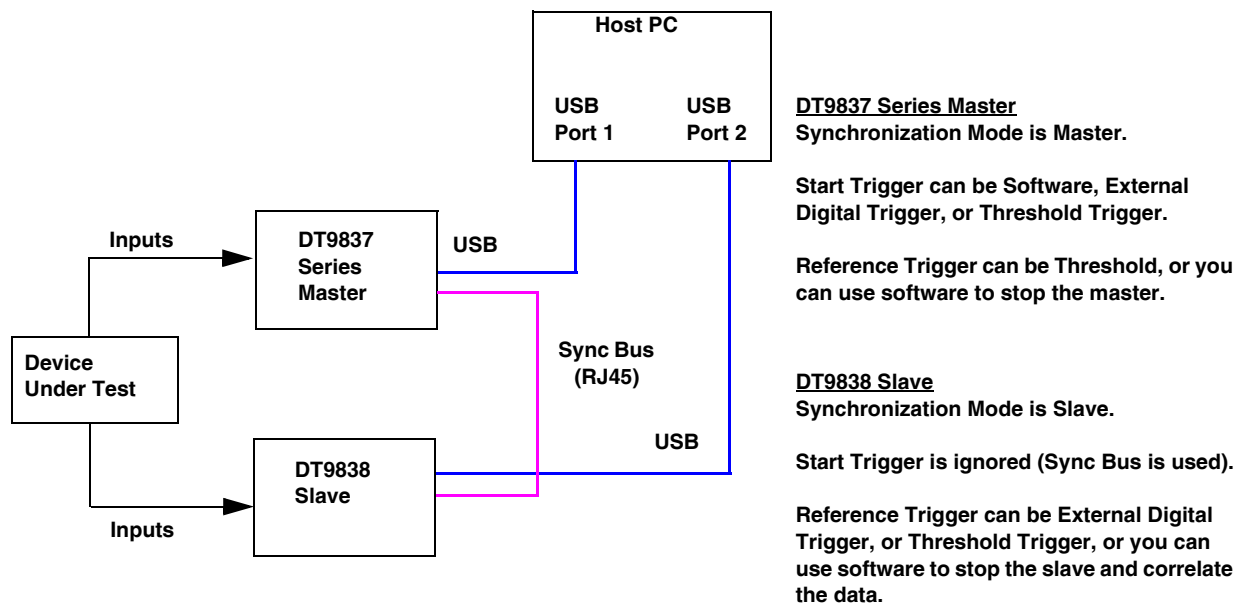

**Figure 55: Synchronizing a Master DT9838 Module and a Slave DT9837 Series Module Using the Sync Bus Connector**

In this case, the start trigger on the master DT9838 can be a software trigger, external digital trigger, or threshold trigger. The reference trigger on the master DT9838 module can be an external digital trigger or threshold trigger.

The start trigger on the slave DT9837 Series module is ignored, since the Sync Bus is used as the start trigger. The reference trigger on the slave DT9837 Series can be the threshold trigger, or you can use software to stop the DT9837 Series module and correlate the data.

Now, consider the case where the DT9837 Series is the master and a DT9838 module is the slave, as shown in Figure 56.



**Figure 56: Synchronizing a Master DT9837 Series Module and a Slave DT9838 Module Using the Sync Bus Connector**

In this case, the start trigger on the master DT9837 Series module can be a software, external digital, or threshold trigger. The reference trigger on the master DT9837 Series module can be the threshold trigger.

The start trigger on the slave DT9838 is ignored, since the Sync Bus is used as the start trigger. The reference trigger on the slave DT9838 module can be an external digital trigger or threshold trigger (the Sync Bus trigger is not supported as a reference trigger in this configuration), or you can use software to stop the DT9838 module and correlate the data.





## ***Supported Device Driver Capabilities***

Data Flow and Operation Options.....	119
Buffering .....	120
Triggered Scan Mode.....	120
Data Encoding.....	120
Channels .....	121
Gain .....	121
Ranges .....	122
Resolution .....	122
Current and Resistance Support .....	122
Thermocouple, RTD, and Thermistor Support .....	123
IEPE Support.....	124
Bridge and Strain Gage Support .....	124
Start Triggers.....	125
Reference Triggers .....	125
Clocks.....	126
Counter/Timers .....	127
Tachometers .....	128

The DT9838 Device Driver provides support for the analog input (A/D) subsystems. For information on how to configure the device driver, refer to [page 34](#).

**Table 5: DT9838 Subsystems**

<b>DT9838</b>	<b>A/D</b>	<b>D/A</b>	<b>DIN</b>	<b>DOUT</b>	<b>C/T</b>	<b>TACH</b>	<b>QUAD</b>
Total Subsystems on Module	1	0	0	0	0	1	0

The tables in this chapter summarize the features available for use with the DT-Open Layers for .NET Class Library and the DT9838 module. The DT-Open Layers for .NET Class Library provides properties that return support information for specified subsystem capabilities.

The first row in each table lists the subsystem types. The first column in each table lists all possible subsystem capabilities. A description of each capability is followed by the property used to describe that capability in the DT-Open Layers for .NET Class Library.

---

**Note:** The following tables include the capabilities that can be queried. However, some capabilities may not be supported by your device. Blank fields represent unsupported options.

---

For more information, refer to the description of these properties in the DT-Open Layers for .NET Class Library on help or *DT-Open Layers for .NET Class Library User's Manual*.

## Data Flow and Operation Options

Table 6: Data Flow and Operation Options

DT9838	A/D	D/A	DIN	DOUT	C/T	TACH	QUAD
Single-Value Operation Support <b>SupportsSingleValue</b>	Yes						
Simultaneous Single-Value Output Operations <b>SupportsSetSingleValues</b>							
Continuous Operation Support <b>SupportsContinuous</b>	Yes					Yes <sup>a</sup>	
Continuous Operation until Trigger <b>SupportsContinuousPreTrigger</b>							
Continuous Operation before & after Trigger <b>SupportsContinuousPrePostTrigger</b>							
Waveform Operations Using FIFO Only <b>SupportsWaveformModeOnly</b>							
Simultaneous Start List Support <b>SupportsSimultaneousStart</b>	Yes						
Supports Programmable Synchronization Modes <b>SupportsSynchronization</b>	Yes						
Synchronization Modes <b>SynchronizationMode</b>	None, Master, Slave						
Interrupt Support <b>SupportsInterruptOnChange</b>							
FIFO Size, in Samples <b>FifoSize</b>	8 kSamples						
Muting and Unmuting the Output Voltage <b>SupportsMute</b>							
Auto-Calibrate Support <b>SupportsAutoCalibrate</b>							

- a. You read the tachometer input channel in the analog input data stream by specifying channel 4 in the A/D channel list.

## Buffering

Table 7: Buffering Options

DT9838	A/D	D/A	DIN	DOUT	C/T	TACH	QUAD
Buffer Support <b>SupportsBuffering</b>	Yes						
Single Buffer Wrap Mode Support <b>SupportsWrapSingle</b>	Yes						
Inprocess Buffer Flush Support <b>SupportsInProcessFlush</b>	Yes						

## Triggered Scan Mode

Table 8: Triggered Scan Mode Options

DT9838	A/D	D/A	DIN	DOUT	C/T	TACH	QUAD
Triggered Scan Support <b>SupportsTriggeredScan</b>							
Maximum Number of CGL Scans per Trigger <b>MaxMultiScanCount</b>	1	0	0	0	0	0	
Maximum Retrigger Frequency <b>MaxRetriggerFreq</b>	0	0	0	0	0	0	
Minimum Retrigger Frequency <b>MinRetriggerFreq</b>	0	0	0	0	0	0	

## Data Encoding

Table 9: Data Encoding Options

DT9838	A/D	D/A	DIN	DOUT	C/T	TACH	QUAD
Binary Encoding Support <b>SupportsBinaryEncoding</b>	Yes					Yes	
Twos Complement Support <b>SupportsTwosCompEncoding</b>							
Returns Floating-Point Values <b>ReturnsFloats</b>							



## Channels

**Table 10: Channel Options**

DT9838	A/D	D/A	DIN	DOUT	C/T	TACH	QUAD
Number of Channels <b>NumberOfChannels</b>	4 <sup>a</sup>					1 <sup>a</sup>	
SE Support <b>SupportsSingleEnded</b>							
SE Channels <b>MaxSingleEndedChannels</b>							
DI Support <b>SupportsDifferential</b>	Yes						
DI Channels <b>MaxDifferentialChannels</b>	4						
Maximum Channel-Gain List Depth <b>CGLDepth</b>	5 <sup>a</sup>						
Simultaneous Sample-and-Hold Support <b>SupportsSimultaneousSampleHold</b>	Yes						
Channel-List Inhibit <b>SupportsChannelListInhibit</b>							
Support MultiSensor Inputs <b>SupportsMultiSensor</b>							
Bias Return Termination Resistor Support <b>SupportsInputTermination</b>							

- a. Four analog input channels are supported and 1 tachometer channel is supported. The analog input channels are numbered 0 to 3. You read the tachometer input channel by specifying channel 4 in the A/D channel list.

## Gain

**Table 11: Gain Options**

DT9838	A/D	D/A	DIN	DOUT	C/T	TACH	QUAD
Programmable Gain Support <b>SupportsProgrammableGain</b>							
Number of Gains <b>NumberOfSupportedGains</b>	1						
Gains Available <b>SupportedGains</b>	1						

## Ranges

Table 12: Range Options

DT9838	A/D	D/A	DIN	DOUT	C/T	TACH	QUAD
Number of Voltage Ranges <b>NumberOfRanges</b>	1						
Available Ranges <b>SupportedVoltageRanges</b>	±0.25 V						

## Resolution

Table 13: Resolution Options

DT9838	A/D	D/A	DIN	DOUT	C/T	TACH	QUAD
Software Programmable Resolution <b>SupportsSoftwareResolution</b>							
Number of Resolutions <b>NumberOfResolutions</b>	1					1	
Available Resolutions <b>SupportedResolutions</b>	24					31	

## Current and Resistance Support

Table 14: Current and Resistance Support Options

DT9838	A/D	D/A	DIN	DOUT	C/T	TACH	QUAD
Current Support <b>SupportsCurrent</b>							
Current Output Support <b>SupportsCurrentOutput</b>							
Resistance Support <b>SupportsResistance</b>							
Software Programmable External Excitation Current Source for Resistance <b>SupportsExternalExcitationCurrentSrc</b>							
Software Programmable Internal Excitation Current Source <b>SupportsInternalExcitationCurrentSrc</b>							
Available Excitation Current Source Values <b>SupportedExcitationCurrentValues</b>							

## Thermocouple, RTD, and Thermistor Support

Table 15: Thermocouple, RTD, and Thermistor Support Options

DT9838	A/D	D/A	DIN	DOUT	C/T	TACH	QUAD
Thermocouple Support <b>SupportsThermocouple</b>							
RTD Support <b>SupportsRTD</b>							
Thermistor Support <b>SupportsThermistor</b>							
Voltage Converted to Temperature in Hardware <b>SupportsTemperatureDataInStream</b>							
Supported Thermocouple Types <b>ThermocoupleType</b>							
Supports CJC Source Internally in Hardware <b>SupportsCjcSourceInternal</b>							
Supports CJC Channel <b>SupportsCjcSourceChannel</b>							
Available CJC Channels <b>CjcChannel</b>							
Supports Interleaved CJC Values in Data Stream <b>SupportsInterleavedCjcTemperaturesInStream</b>							
Supported RTD Types <b>RTDType</b>							
RTD R0 Coefficient <b>RtdR0</b>							
Supports Programmable Filters <b>SupportsTemperatureFilters</b>							
Programmable Filter Types <b>TemperatureFilterType</b>							

## IEPE Support

Table 16: IEPE Support Options

DT9838	A/D	D/A	DIN	DOUT	C/T	TACH	QUAD
IEPE Support <b>SupportsIEPE</b>							
Software Programmable AC Coupling <b>SupportsACCoupling</b>							
Software Programmable DC Coupling <b>SupportsDCCoupling</b>							
Software Programmable External Excitation Current Source <b>SupportsExternalExcitationCurrentSrc</b>							
Software Programmable Internal Excitation Current Source <b>SupportsInternalExcitationCurrentSrc</b>							
Available Excitation Current Source Values <b>SupportedExcitationCurrentValues</b>							

## Bridge and Strain Gage Support

Table 17: Bridge and Strain Gage Support Options

DT9838	A/D	D/A	DIN	DOUT	C/T	TACH	QUAD
Bridge Support <b>SupportsBridge</b>	Yes						
Supported Bridge Configurations <b>BridgeConfiguration</b>	Full Bridge Half Bridge Quarter Bridge						
Strain Gage Support <b>SupportsStrainGage</b>	Yes						
Supported Strain Gage Bridge Configurations <b>StrainGageBridgeConfiguration</b>	Full -Bridge Bending Full-Bridge Bending Poisson Full-Bridge Axial Poisson Half-Bridge Poisson Half-Bridge Bending Quarter-Bridge Quarter-Bridge Temp Comp						
External Excitation Voltage <b>SupportsExternalExcitationVoltage</b>							
Internal Excitation Voltage <b>SupportsInternalExcitationVoltage</b>	Yes						
Shunt Calibration <b>SupportsShuntCalibration</b>	Yes						
Voltage Excitation Per Channel <b>SupportedPerChannelVoltageExcitation</b>							
Minimum Excitation Voltage <b>MinExcitationVoltage</b>	0 V DC						
Maximum Excitation Voltage <b>MaxExcitationVoltage</b>	10 V DC						

## Start Triggers

Table 18: Start Trigger Options

DT9838	A/D	D/A	DIN	DOUT	C/T	TACH	QUAD
Software Trigger Support <b>SupportsSoftwareTrigger</b>	Yes <sup>a</sup>					Yes	
External Positive TTL Trigger Support <b>SupportsPosExternalTTLTrigger</b>	Yes <sup>a</sup>						
External Negative TTL Trigger Support <b>SupportsNegExternalTTLTrigger</b>	Yes <sup>a</sup>						
External Positive TTL Trigger Support for Single-Value Operations <b>SupportsSvPosExternalTTLTrigger</b>							
External Negative TTL Trigger Support for Single-Value Operations <b>SupportsSvNegExternalTTLTrigger</b>							
Positive Threshold Trigger Support <b>SupportsPosThresholdTrigger</b>	Yes <sup>a</sup>						
Negative Threshold Trigger Support <b>SupportsNegThresholdTrigger</b>	Yes <sup>a</sup>						
Digital Event Trigger Support <b>SupportsDigitalEventTrigger</b>							

- a. The start trigger also is used for the tachometer input channel (channel 4) if it is specified as part of the analog input channel list. To specify the Sync Bus as the start trigger for the module, set the SynchronizationMode of the A/D subsystem to Slave; any other start trigger for the module is then ignored.

## Reference Triggers

Table 19: Reference Trigger Options

DT9838	A/D	D/A	DIN	DOUT	C/T	TACH	QUAD
External Positive TTL Trigger Support <b>SupportsPosExternalTTLTrigger</b>	Yes <sup>a</sup>						
External Negative TTL Trigger Support <b>SupportsNegExternalTTLTrigger</b>	Yes <sup>a</sup>						
Positive Threshold Trigger Support <b>SupportsPosThresholdTrigger</b>	Yes <sup>a</sup>						
Negative Threshold Trigger Support <b>SupportsNegThresholdTrigger</b>	Yes <sup>a</sup>						
Digital Event Trigger Support <b>SupportsDigitalEventTrigger</b>							
Sync Bus Support <b>SupportsSyncBusTrigger</b>	Yes <sup>a</sup>						
Analog Input Channels Supported for the Threshold Trigger <b>SupportedThresholdTriggerChannels</b>	0, 1, 2, 3						
Post-Trigger Scan Count Support <b>SupportsPostTriggerScanCount</b>	Yes						

- a. The reference trigger also is used for the tachometer input channel (channel 4) if it is specified as part of the analog input channel list.

# Clocks

Table 20: Clock Options

DT9838	A/D	D/A	DIN	DOUT	C/T	TACH	QUAD
Internal Clock Support <b>SupportsInternalClock</b>	Yes <sup>a</sup>						
External Clock Support <b>SupportsExternalClock</b>						Yes	
Simultaneous Input/Output on a Single Clock Signal <b>SupportsSimultaneousClocking</b>							
Base Clock Frequency <b>BaseClockFrequency</b>	27487790					12 MHz	
Maximum Clock Divider <b>MaxExtClockDivider</b>	1.0					1.0	
Minimum Clock Divider <b>MinExtClockDivider</b>	1.0					1.0	
Maximum Frequency <b>MaxFrequency</b>	52.734 kHz					6 MHz	
Minimum Frequency <b>MinFrequency</b>	195.3 Hz					0.00559 Hz	

- a. The internal clock is also used to pace the tachometer input operation if the tachometer input channel (channel 4) if it is specified as part of the analog input channel list.

## Counter/Timers

**Table 21: Counter/Timer Options**

DT9838	A/D	D/A	DIN	DOUT	C/T	TACH	QUAD
Cascading Support <b>SupportsCascading</b>							
Event Count Mode Support <b>SupportsCount</b>							
Generate Rate Mode Support <b>SupportsRateGenerate</b>							
One-Shot Mode Support <b>SupportsOneShot</b>							
Repetitive One-Shot Mode Support <b>SupportsOneShotRepeat</b>							
Up/Down Counting Mode Support <b>SupportsUpDown</b>							
Edge-to-Edge Measurement Mode Support <b>SupportsMeasure</b>							
Continuous Edge-to-Edge Measurement Mode Support <b>SupportsContinuousMeasure</b>							
High to Low Output Pulse Support <b>SupportsHighToLowPulse</b>							
Low to High Output Pulse Support <b>SupportsLowToHighPulse</b>							
Variable Pulse Width Support <b>SupportsVariablePulseWidth</b>							
None (internal) Gate Type Support <b>SupportsGateNone</b>							
High Level Gate Type Support <b>SupportsGateHighLevel</b>							
Low Level Gate Type Support <b>SupportsGateLowLevel</b>							
High Edge Gate Type Support <b>SupportsGateHighEdge</b>							
Low Edge Gate Type Support <b>SupportsGateLowEdge</b>							
Level Change Gate Type Support <b>SupportsGateLevel</b>							
Clock-Falling Edge Type <b>SupportsClockFalling</b>							
Clock-Rising Edge Type <b>SupportsClockRising</b>							
Gate-Falling Edge Type <b>SupportsGateFalling</b>							
Gate-Rising Edge Type <b>SupportsGateRising</b>							
Interrupt-Driven Operations <b>SupportsInterrupt</b>							

# Tachometers

**Table 22: Tachometer Options**

<b>DT9838</b>	<b>A/D</b>	<b>D/A</b>	<b>DIN</b>	<b>DOUT</b>	<b>C/T</b>	<b>TACH</b>	<b>QUAD</b>
Tachometer Falling Edges <b>SupportsFallingEdge</b>						Yes	
Tachometer Rising Edges <b>SupportsRisingEdge</b>						Yes	
Tachometer Stale Data Flag <b>SupportsStaleDataFlag</b>						Yes	





## ***Troubleshooting***

General Checklist .....	130
Technical Support .....	132
If Your Module Needs Factory Service .....	133

## General Checklist

Should you experience problems using a DT9838 module, do the following:

1. Read all the documentation provided for your product, including any “Read This First” information.
2. Check the DT Omni software for any README files and ensure that you have used the latest installation and configuration information available.
3. Check that your system meets the requirements stated in the README file on [page 28](#).
4. Check that you have installed your hardware properly using the instructions in [Chapter 2](#).
5. Check that you have installed and configured the device driver properly using the instructions in [Chapter 2](#).
6. Check that you have wired your signals properly using the instructions in [Chapter 3](#).
7. Search the Knowledgebase in the Support section of the web site (at [www.mccdaq.com](http://www.mccdaq.com)) for an answer to your problem.

If you still experience problems, try using the information in [Table 23](#) to isolate and solve the problem. If you cannot identify the problem, refer to [page 132](#).

**Table 23: Troubleshooting Problems**

Symptom	Possible Cause	Possible Solution
Module is not recognized	You plugged the module into your computer before installing the device driver.	From the Control Panel > System > Hardware > Device Manager, uninstall any unknown devices (showing a yellow question mark). Then, run the DT Omni setup program to install the USB device drivers, and reconnect your USB module to the computer.
Module does not respond.	The module configuration is incorrect.	Check the configuration of your device driver; see the instructions in <a href="#">Chapter 2</a> .
	The module is damaged.	Contact Data Translation for technical support; refer to <a href="#">page 132</a> .
Intermittent operation.	Loose connections or vibrations exist.	Check your wiring and tighten any loose connections or cushion vibration sources; see the instructions in <a href="#">Chapter 3</a> .
	The module is overheating.	Check environmental and ambient temperature; consult the module's specifications on <a href="#">page 146</a> of this manual and the documentation provided by your computer manufacturer for more information.
	Electrical noise exists.	Check your wiring and either provide better shielding or reroute unshielded wiring; see the instructions in <a href="#">Chapter 3</a> .

**Table 23: Troubleshooting Problems (cont.)**

Symptom	Possible Cause	Possible Solution
Device failure error reported.	The DT9838 module cannot communicate with the Microsoft bus driver or a problem with the bus driver exists.	Check your cabling and wiring and tighten any loose connections; see the instructions in <a href="#">Chapter 3</a> .
	The DT9838 module was removed while an operation was being performed.	Ensure that your DT9838 module is properly connected; see the instructions in <a href="#">Chapter 2</a> .
Data appears to be invalid.	An open connection exists.	Check your wiring and fix any open connections; see the instructions in <a href="#">Chapter 3</a> .
	A transducer is not connected to the channel being read.	Check the transducer connections; see the instructions in <a href="#">Chapter 3</a> .
	Incorrect channel configuration.	Check your wiring and ensure that what you specify in software matches your hardware configuration; see the instructions in <a href="#">Chapter 3</a> .
	The DT9838 module is out of calibration.	DT9838 modules are calibrated at the factory. If you want to readjust the calibration of the analog input or analog output circuitry, refer to <a href="#">Chapter 8</a> starting on <a href="#">page 135</a> .
USB 2.0 is not recognized.	Your operating system does not have the appropriate Service Pack installed.	Ensure that you load the appropriate Windows Service Pack. If you are unsure of whether you are using USB 2.0 or USB 1.1, run the Open Layers Control Panel applet, described in <a href="#">Chapter 2</a> .
	Standby mode is enabled on your PC.	For some PCs, you may need to disable standby mode on your system for proper USB 2.0 operation. Consult Microsoft for more information.

## **Technical Support**

If you have difficulty using a DT9838 module, Data Translation's Technical Support Department is available to provide technical assistance.

To request technical support, go to our web site at <http://www.mccdaq.com> and click on the Support link.

When requesting technical support, be prepared to provide the following information:

- Your product serial number
- The hardware/software product you need help on
- The version of the Omni software that you are using
- Your contract number, if applicable

If you are located outside the USA, contact your local distributor; see our web site ([www.mccdaq.com](http://www.mccdaq.com)) for the name and telephone number of your nearest distributor.

## ***If Your Module Needs Factory Service***

Most hardware models can be functionally tested, evaluated for repairs (if needed), and calibrated to factory specifications. An RMA# must be obtained from Applications Engineering in advance of sending any product back to Measurement Computing (Data Translation is a Measurement Computing company). Customers outside the USA must contact their local distributor for a return procedure. Calibration certificates for most analog models can be obtained for a fee (certificate must be requested at time of RMA# assignment).





# ***Calibration***

Using the Calibration Utility .....	136
Calibrating the Analog Input Subsystem .....	137
Calibrating the Internal Analog Output Circuitry (Excitation Voltage) .....	139

## Using the Calibration Utility

The DT9838 module is calibrated at the factory and should not require calibration for initial use. We recommend that you check and, if necessary, readjust the calibration of the DT9838 module every six months using the DT9838 Calibration Utility.

---

**Note:** Ensure that you installed the DT9838 Device Driver prior to using the DT9838 Calibration Utility.

---

Start the DT9838 Calibration Utility as follows:

1. Click **Start** from the Task Bar.
2. Select **Programs | Data Translation, Inc | Calibration | DT9838 Calibration Utility**.  
*The main menu of the DT9838 Calibration Utility appears.*
3. Select the module to calibrate, and then click **OK**.

Once the DT9838 Calibration Utility is running, you can calibrate the analog input circuitry (either automatically or manually), described on [page 137](#), and/or calibrate the internal analog output circuitry that is responsible for providing the excitation voltage for the module, described on [page 139](#).



## Calibrating the Analog Input Subsystem

This section describes how to use the DT9838 Calibration Utility to calibrate the analog input subsystem of a DT9838 module.

You must calibrate each analog input channel separately.

---

**IMPORTANT:** Before calibrating the analog input subsystem, ensure that you have attached all of your sensors and configured the sampling frequency of the device. This ensures that the proper current is detected and the proper excitation value is supplied to each channel.

---

### Connecting a Precision Voltage Source

To calibrate the analog input circuitry, you need to connect an external precision voltage source capable of generating +240 mV to the analog input channels of the DT9838 module.

### Using the Auto-Calibration Procedure

Auto-calibration is the easiest to use and is the recommended calibration method. To auto-calibrate the analog input subsystem, do the following:

1. Select the **A/D Calibration** tab of the DT9838 Calibration Utility.
2. Under the **Channel Number** drop-down list box in the **Automatic Calibration** area, select the analog input channel to calibrate.
3. Set the voltage supply on your selected channel to 0.0000V.
4. Enter the sampling frequency at which you want to run (and calibrate) the DT9838 module.
5. Click the Auto Calibration **Start** button.  
*A message appears notifying you to verify that 0.0000 V is applied to the channel.*
6. Verify that the supplied voltage to your selected channel is 0.0000 V, and then click **OK**.  
*The offset value is calibrated. When the offset calibration is complete, a message appears notifying you to set the input voltage of the channel to +240 mV.*
7. Check that the supplied voltage to your selected channel is +240 mV, and then click **OK**.  
*The gain value is calibrated and a completion message appears.*
8. Repeat steps 2 through 7 for the remaining analog input channels.

---

**Note:** At any time, you can click **Restore Factory Settings** to reset the A/D calibration values to their original factory settings. This process will undo any auto or manual calibration settings.

---

## Using the Manual Calibration Procedure

If you want to manually calibrate the analog input circuitry instead of auto-calibrating it, do the following for each analog input channel:

1. Select the analog input channel that you want to calibrate.
2. Enter the sampling frequency at which you want to run (and calibrate) the DT9838 module.
3. Adjust the offset as follows:
  - a. Verify that 0.0000 V is applied to the selected analog input channel.
  - b. Under **Sampling**, click **Start** to start sampling data from the selected analog input channel.  
*The current voltage reading for this channel is displayed in the AD Value text box.*
  - c. Adjust the offset by entering values between 0 and 255 in the **Offset** edit box, or by clicking the up/down buttons until the **AD Value** is 0.0000 V.
  - d. Under **Sampling**, click **Stop** to stop sampling data from the selected analog input channel.
4. Adjust the gain as follows:
  - a. Verify that +240 mV is applied to the selected analog input channel.
  - b. Under **Sampling**, click **Start** to start sampling data from the selected analog input channel.  
*The current voltage reading for this channel is displayed in the AD Value text box.*
  - c. Adjust the gain by entering values between 0 and 255 in the **Gain** edit box, or by clicking the up/down buttons until the **AD Value** is 240 mV.
  - d. Under **Sampling**, click **Stop** to stop sampling data from the selected analog input channel.
5. Repeat steps 1 through 5 for the remaining analog input channels.

---

**Note:** At any time, you can click **Restore Factory Settings** to reset the A/D calibration values to their original factory settings. This process will undo any auto or manual calibration settings.

---

## Calibrating the Internal Analog Output Circuitry (Excitation Voltage)

This section describes how to use the DT9838 Calibration Utility to calibrate the internal analog output circuitry that is used to generate the excitation voltage for the DT9838 module.

This procedure assumes that you have connected a STP STRAIN General-Purpose Accessory, STP STRAIN 120 Quarter-Bridge Completion Accessory, or STP STRAIN 350 Quarter-Bridge Completion Accessory to the DT9838 module.

### Connecting a Digital Voltmeter

To calibrate the internal analog output circuitry, you need an external digital voltmeter (DVM). Connect the digital voltmeter to the STP STRAIN, STP STRAIN 120, or STP STRAIN 350 accessory as follows:

1. Connect the digital voltmeter across signals Excitation+ (pin 6) and Excitation– (pin 7) on the STP STRAIN, STP STRAIN 120, or STP STRAIN 350 accessory.
2. Connect signals Excitation– (pin 7) to Sense– (pin 5) on the STP STRAIN, STP STRAIN 120, or STP STRAIN 350 accessory.
3. Connect signals Excitation+ (pin 6) to Sense+ (pin 4) on the STP STRAIN, STP STRAIN 120, or STP STRAIN 350 accessory.

### Calibrating the Analog Output Circuitry

Once you have connected the digital voltmeter to the STP STRAIN, STP STRAIN 120, or STP STRAIN 350 accessory, which is connected to the DT9838 module, calibrate the analog output circuitry, as follows:

1. Select the **Bridge Internal Excitation DAC Calibration** tab of the DT9838 Calibration Utility.
2. Read the value that is displayed by the digital voltmeter.
3. Enter values between 0 and 65535 in the edit box or by clicking the up/down buttons until the value that is displayed by the digital voltmeter is 0.1 V.
4. Click **Next**.
5. Read the value that is displayed by the digital voltmeter.
6. Enter values between 0 and 65535 in the edit box or by clicking the up/down buttons until the value that is displayed by the digital voltmeter is 10 V.

---

**Note:** At any time, you can click **Restore Factory Settings** to reset the A/D calibration values to their original factory settings. This process will undo any auto or manual calibration settings.

---

7. When you are finished calibrating the module, click **Done** to close the calibration utility.





# ***Specifications***

Analog Input Specifications .....	142
Bridge Specifications .....	143
Tachometer Input Specifications .....	144
Trigger Specifications .....	145
Power, Physical, and Environmental Specifications .....	146
Regulatory Specifications .....	147
Connector Specifications .....	148
External Power Supply Specifications .....	149

## Analog Input Specifications

Table 24 lists the specifications for the A/D subsystem on the DT9838 module. Performance specifications are typical for the operating range of 0° C to 55° C.

**Table 24: A/D Subsystem Specifications**

Feature	DT9838 Specifications
Number of analog inputs	4 differential
Resolution	24 bits
Input range	±250 mV
Data encoding	offset binary
Sample rate per channel	195 Samples/s to 52734 Samples/s, simultaneous sampling
Passband (±0.005 dB flatness)	DC to 0.453 * data rate
Group delay	39/data rate, seconds
Accuracy Gain error: Offset error: Gain drift: Offset drift:	0.02% of reading ±25 µV ±10 ppm/°C ±2 µV/°C
Input Noise	3 µVrms
SFDR (1 kHz, -1 dB Full-Scale)	95 dB
Total Harmonic Distortion 1 kHz, -20 dB Full-Scale 10 kHz, -20 dB Full-Scale	-100 dB -90 dB
DC differential input impedance	20 MΩ
Differential input voltage protection	±30 V
Channel crosstalk 1 kHz: 10 kHz:	>100 dB >100 dB
Maximum input voltage	±40 V
ESD protection Arc: Contact:	8 kV 4 kV
Input FIFO	8 kSamples

## Bridge Specifications

Table 25 lists the bridge specifications for the DT9838 module.

**Table 25: Bridge Excitation Specifications**

Feature	DT9838 Specifications
Supported bridge configurations	Full, Half, and Quarter (Quarter-Bridge requires external bridge completion resistor)
Internal Half-Bridge completion resistors	10 k $\Omega$ divider, 0.05% matching, 2 ppm/ $^{\circ}$ C tracking
Bridge excitation	0 V to 10 V, 167 $\mu$ V resolution
Bridge excitation accuracy	$\pm$ 2 mV
Bridge excitation stability	$\pm$ 12 $\mu$ V/ $^{\circ}$ C $\pm$ 10 ppm/ $^{\circ}$ C
Bridge excitation noise	50 $\mu$ Vrms
Shunt calibration resistor	100 k $\Omega$ , 0.1%, 25 ppm/ $^{\circ}$ C
Short circuit current limit	50 mA each channel

## Tachometer Input Specifications

Table 26 lists the specifications for the tachometer input on the DT9838 module.

**Table 26: Tachometer Input Specifications**

Feature	DT9838 Specifications
Number of channels	1
Resolution	31 bits per channel
Input voltage range	$\pm 30$ V
Threshold voltage	$\pm 2$ V with 0.5 V hysteresis
Maximum input frequency	1 MHz
Minimum pulse width high/low (minimum amount of time it takes a C/T to recognize an input pulse)	0.4 $\mu$ s
Clock frequency for tachometer measurements	12 MHz (83 ns resolution)
Input termination	None



## Trigger Specifications

Table 27 lists the specifications for the trigger on the DT9838 module.

**Table 27: Trigger Specifications**

Feature	DT9838 Specifications
Trigger sources Internal software trigger: External digital trigger: Analog threshold trigger:	Software-initiated Software-selectable Software-selectable
External digital trigger Input type: Logic family: Input logic load: Lower threshold: Upper threshold: Hysteresis: Input sink current: Minimum pulse width high/low: Maximum input signal: Input termination:	Edge-sensitive, positive trigger LVTTTL inputs 1 LVTTTL 1.1 V 1.3 V 0.2 V 33 $\mu$ A 200 ns $\pm$ 30 V None
Trigger delay	1 conversion period maximum

## Power, Physical, and Environmental Specifications

Table 28 lists the power, physical, and environmental specifications for the DT9838 module.

**Table 28: Power, Physical, and Environmental Specifications**

Feature	DT9838 Specifications
USB Power +5 V Standby: +5 V Operation with no Bridges Powered: +5 V Operation with Bridges Powered <sup>a</sup> :	50 mA typical 320 mA typical 500 mA maximum (USB power only) 200 mA typical (external power supply)
Optional External Power Requirement (optimal for enhanced bridge drive capability)	+5 V to 24 V @ 2 W
Optional EP394 External Power Supply <sup>b</sup> Output: Input voltage: Input current: Frequency:	5 V @ 1.6 A 100 to 240 V AC ±10% 250 mA 50 to 60 Hz
Physical Dimensions - DT9838 Length: Width: Height: Weight:	8.880 inches (225.55 mm) 4.170 inches (105.92 mm) 1.575 inches (40 mm) 21.32 ounces (604.5 g)
Physical Dimensions - DT9838-OEM Length: Width: Height: Weight:	8.800 inches (223.52 mm) 3.937 inches (100 mm) 0.712 inches (18.08 mm) 5.4 ounces (153 g)
Environmental Operating temperature range: Storage temperature range: Relative humidity: Altitude:	0° C to 55° C -25° C to 85° C To 95%, noncondensing To 10,000 feet

- a. See Table 1 on page 29 for example configurations of bridges powered from an external supply.  
 b. The optional EP394 external power supply provides 5 V to enhance the bridge drive capability. Refer to page 29 for more information.

## Regulatory Specifications

Table 29 lists the regulatory specifications for the DT9838 module.

**Table 29: Regulatory Specifications**

Feature	Specifications
Emissions (EMI)	FCC Part 15, Class A EN55011:2007 (Based on CISPR-11, 2003/A2, 2006)
Immunity	EN61326-1:2006 Electrical Equipment for Measurement, Control, and Laboratory Use  <u>EMC Requirements</u> EN61000-4-2:2001 Electrostatic Discharge (ESD) 4 kV contact discharge, 8 kV air discharge, 4 kV horizontal and vertical coupling planes  EN61000-4-3:2002 Radiated electromagnetic fields, 3 V/m, 80 to 1000 MHz; 3 V/m, 1.4 GHz to 2 GHz; 1 V/m, 2 GHz to 2.7 GHz  EN61000-4-4:2004 Electrical Fast Transient/Burst (EFT) 1 kV on data cables  EN61000-4-6:2003 Conducted immunity requirements, 3 Vrms on data cables 150 kHz to 80 MHz
RoHS (EU Directive 2002/95/EG)	Compliant (as of July 1st, 2006)

## Connector Specifications

Table 30 lists the cable and connector specifications for the DT9838 module.

**Table 30: DT9838 Cable and Connector Specifications**

Feature	DT9838 Specifications
Analog input connectors (RJ50)	Tyco 5558067-1
Tachometer/external trigger connector (4-position Screw terminal block)	Header: Phoenix Contact 1803293 Plug: Phoenix Contact 1803594
External power supply	Jack on the module: Switchcraft #L722RA Mating plug assembly, 0.08 inch: Switchcraft #S761K
Sync Bus connector (RJ45)	Molex part number 44661-0001
USB connector	AMP 292304-2

## External Power Supply Specifications

Table 31 lists the specifications for the optional EP394 +5 V external power supply that can be used with the DT9838 module.

**Table 31: External Power Supply (EP394) Specifications**

Feature	Specifications
Type	FRIWO medical power supply (GPP 10)
Input voltage	100 to 240 V AC ( $\pm 10\%$ )
Input current	250 mA
Frequency	50 to 60 Hz
Efficiency	80% typical at full load
Output voltage	5 V
Output current	1600 mA
Output ripple voltage	75 mV pp
Regulatory standards	UL, VDE, CE, Energy Star compliant





## ***Connector Pin Assignments***

Analog Input Connectors .....	152
Sync Bus Connector .....	153
External Trigger and Tachometer Connector.....	154
External USB Connector .....	155
External Power Connector .....	156
Screw Terminals on the STP STRAIN, STP STRAIN 120, and STP STRAIN 350 .....	157

## Analog Input Connectors

Figure 57 shows the orientation of the pins used in each of the analog input (RJ50) connectors on the DT9838 module.

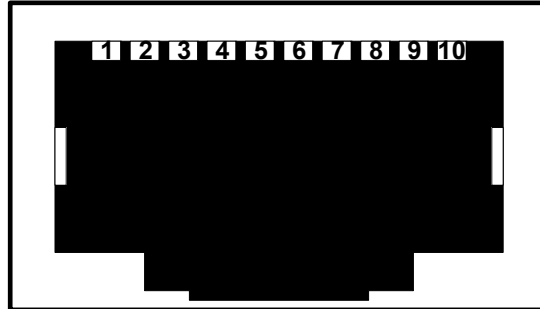

Figure 57: Analog Input (RJ50) Connector

Table 32 lists the pin assignments of the analog input (RJ50) connectors.

Table 32: Pin Assignments of the Analog Input (RJ50) Connectors

Pin	Signal Description
1	RSHUNT+
2	AIN+
3	AIN-
4	SENSE+
5	SENSE-
6	EXC+
7	EXC-
8	TEDS Data
9	TEDS Return
10	RSHUNT -



## Sync Bus Connector

Figure 58 shows the orientation of the pins used in the Sync Bus (RJ45) connector (connector J7) on the DT9838 module.

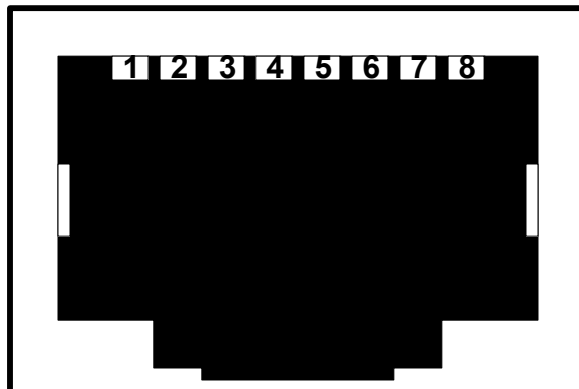

Figure 58: Sync Bus (RJ45) Connector

Table 33 lists the pin assignments of the Sync Bus (RJ45) connector.

Table 33: Sync Bus (RJ45) Connector Pin Assignments

Pin	Description
1	Clock + (An LVDS signal for synchronizing data collection between two modules.)
2	Clock –
3	Trigger + (An LVTTTL signal that is asserted low for triggering between modules.)
4	Sync + (An LVTTTL signal that is asserted low for synchronizing all the analog input signals between modules for simultaneous sample-and-hold applications.)
5	Sync – (Connected to digital ground through a 100 $\Omega$ resistor.)
6	Trigger – (Connected to digital ground through a 100 $\Omega$ resistor.)
7	No Connect
8	No Connect

## External Trigger and Tachometer Connector

Figure 59 shows the orientation of the screw terminals used in the External Trigger and Tachometer connector (connector J6) on the DT9838 module.

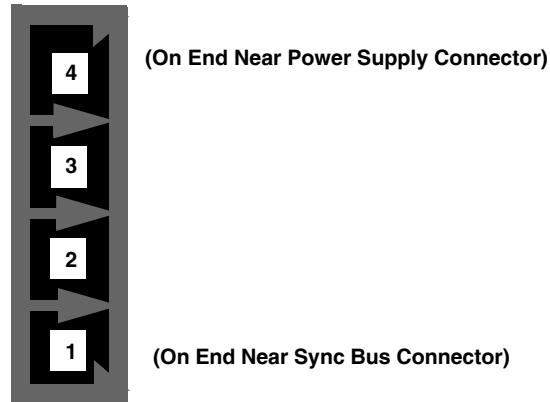

Figure 59: External Trigger and Tachometer Connector

Table 34 lists the screw terminal assignments for the External Trigger and Tachometer Connector.

Table 34: External Trigger and Tachometer Connector  
Screw Terminal Assignments

Pin	Description
1	Tachometer
2	Tachometer Return
3	External Trigger
4	External Trigger Return

## External USB Connector

Figure 60 shows the orientation of the pins used in the external USB connector (connector J8) on the DT9838 module.

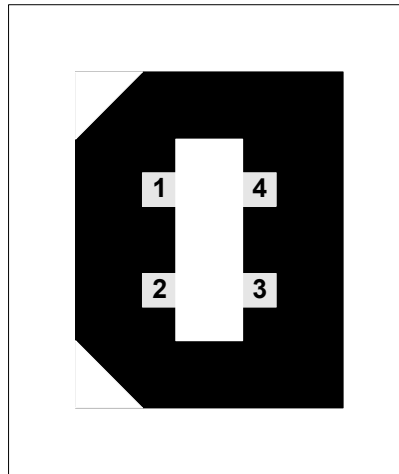

Figure 60: External USB Connector

Table 35 lists the pin assignments of the USB connector.

Table 35: J8 USB Connector Pin Assignments

Pin	Description
1	USB +5 V
2	USB Data –
3	USB Data +
4	USB Ground

## External Power Connector

You can connect an external +5 V to +24 VDC power supply to the auxiliary power connector on the DT9838 module to enhance the bridge drive capability. (Refer to [page 29](#) for more information on enhancing the bridge drive capability.) [Figure 61](#) shows the layout of the external power connector on the DT9838 module.

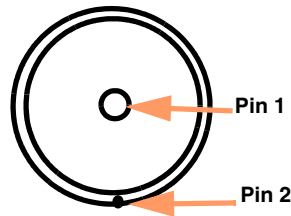

**Figure 61: Layout of the External Power Connector**

[Table 36](#) lists the pin assignments for the external power connector on the DT9838 module.

**Table 36: Pin Assignments for the External Power Connector**

Connector Pin Number	Signal Description
1	+5 VDC to +24 VDC
2	Ground

## Screw Terminals on the STP STRAIN, STP STRAIN 120, and STP STRAIN 350

The screw terminal assignments of the STP STRAIN, STP STRAIN 120, and STP STRAIN 350 accessories, listed in [Table 37](#), match the pin designations of the RJ50 analog input connectors on the DT9838.

**Table 37: Pin Assignments for the RJ50 Connectors**

Pin	Signal Description
1	RSHUNT+
2	AIN+
3	AIN-
4	SENSE+
5	SENSE-
6	EXC+
7	EXC-
8	TEDS DATA
9	TEDS RETURN
10	RSHUNT -



## A

- A/D sample clock 104
- A/D subsystem, specifications 142, 143
- accessories 21, 112, 113
  - EP394 external power supply 21, 29
  - STP STRAIN 120 quarter-bridge completion 19, 40
  - STP STRAIN 350 quarter-bridge completion 20, 40
  - STP STRAIN general-purpose screw terminal panel 19, 40
- administrator privileges 34
- aliasing 104
- analog input
  - calibrating 137
  - channel list 91
  - continuous operations 105
  - conversion modes 105
  - error conditions 109
  - single-value operations 105
  - triggers 107
- analog input features
  - A/D sample clock 104
  - bridge configurations 92
  - bridge excitation 100
  - channels 91
  - connector pin assignments 39
  - gain 104
  - input ranges 104
  - lead wire correction 100
  - offset nulling 103
  - remote sensing 100
  - resolution 104
  - shunt calibration 101
  - specifications 142, 143
  - TEDS 103
- applet, Open Layers Control Panel 131

## B

- base clock frequency 126
- BaseClockFrequency 126
- binary data encoding 120
- bridge channels
  - configurations 124
  - support 124

- bridge configurations 92, 93
  - Full-Bridge Axial Poisson 63, 99
  - Full-Bridge Axial Poisson configuration 99
  - Full-Bridge Bending 57, 97
  - Full-Bridge Bending configuration 97
  - Full-Bridge Bending Poisson 60, 98
  - Full-Bridge Bending Poisson configuration 98
  - Half-Bridge Bending 54, 93, 96
  - Half-Bridge Bending configuration 96
  - Half-Bridge Poisson 50, 93, 95
  - Half-Bridge Poisson configuration 95
  - Quarter-Bridge 42, 93, 94
  - Quarter-Bridge configuration 93, 94
  - Quarter-Bridge Temp Comp 47, 93, 95
  - Quarter-Bridge Temp Comp configuration 95
- bridge excitation 100
- BridgeConfiguration 124
- buffers 109, 120
  - inprocess flush 120

## C

- C/C++ programs 17
- cables
  - USB 31, 32
- calibrating the module
  - analog input subsystem 137
  - internal analog output circuitry 139
  - running the calibration utility 136
- CGLDepth 121
- channel list
  - for analog input channels 91
  - specifying the tachometer 110
- channel type, differential 121
- channel-gain list depth 121
- channels
  - analog input 91
  - number of 121
- clocks
  - base frequency 126
  - external 126
  - internal 126
  - maximum external clock divider 126
  - maximum throughput 126
  - minimum external clock divider 126
  - minimum throughput 126
  - simultaneous 126

- connecting to the host computer 31
- connectors
  - analog input 152
  - external +5 V 156
  - external trigger 154
  - external USB 155
  - STP STRAIN 120 accessory 157
  - STP STRAIN 350 accessory 157
  - STP STRAIN accessory 157
  - Sync Bus 153
  - tachometer 154
- continuous analog input
  - post-trigger 119
  - scan operations 105
- continuous digital output 119
- Control Panel applet 131
- conventions used 10
- conversion modes
  - continuous analog input (scan mode) 105
  - single-value analog input 105
- conversion rate 106
- customer service 133

## D

- DAQ Adaptor for MATLAB 17
- data encoding 109, 120
- data flow modes
  - continuous post-trigger 119
  - single-value 119
- DataAcq SDK 17
- definitions 38
- device driver 16, 34
- Device Selection window 73
- differential channels 121
- digital trigger 107, 108
- DT-Open Layers for .NET Class Library 17

## E

- encoding data 109
- environmental specifications 146, 148
- EP386 panel 21, 112, 113
- EP394 +5 V power supply 21, 29
- EP398 RJ50 cables 20, 41
- error conditions 109
- excitation voltage 100
  - calibrating 139
  - internal 124
  - minimum 124
- expansion hub 32

- external +5 V connector 156
- external clock 126
- external clock divider
  - maximum 126
  - minimum 126
- external negative digital trigger 107, 108, 125
- external positive digital trigger 107, 108, 125
- external trigger connector 154
- external trigger input, wiring 70
- external USB connector 155

## F

- factory service 133
- features 14
- FifoSize 119
- frequency
  - analog input operations 104
  - base clock 126
  - internal A/D clock 126
  - internal A/D sample clock 126
  - internal retrigger clock 120
- Full-Bridge Axial Poisson 93
- Full-Bridge Axial Poisson configuration 93
- Full-Bridge Bending 93
- Full-Bridge Bending configuration 93
- Full-Bridge Bending Poisson 93
- Full-Bridge Bending Poisson configuration 93

## G

- gain
  - actual available 121
  - analog input 104
  - number of 121
- general wiring recommendations 38
- group delay 104

## H

- Half-Bridge Bending configuration 93
- Half-Bridge Poisson configuration 93
- hardware features 14
- hot-swapping 31

## I

- inprocess buffers 120
- input ranges 104
- internal analog output circuitry, calibrating 139
- internal clock 126



internal excitation voltage [124](#)

## J

J5 connector [156](#)

## L

LabVIEW [18](#)

lead wire correction [100](#)

LEDs

  Trigger [31](#), [107](#)

  USB [31](#), [32](#), [107](#)

legacy CPL elevated [34](#)

load cells [99](#)

load-cells, wiring [66](#)

LV-Link [18](#)

## M

master device [74](#)

MATLAB [17](#)

MaxDifferentialChannels [121](#)

MaxExcitationVoltage [124](#)

MaxExtClockDivider [126](#)

MaxFrequency [126](#)

MaxMultiScanCount [120](#)

MaxRetriggerFreq [120](#)

MinExcitationVoltage [124](#)

MinExtClockDivider [126](#)

MinFrequency [126](#)

MinRetriggerFreq [120](#)

module specifications [146](#), [148](#)

multiple channels, analog input [91](#)

## N

number of

  differential channels [121](#)

  gains [121](#)

  I/O channels [121](#)

  resolutions [122](#)

  scans per trigger [120](#)

  voltage ranges [122](#)

NumberOfChannels [121](#)

NumberOfRanges [122](#)

NumberOfResolutions [122](#)

NumberOfSupportedGains [121](#)

Nyquist Theorem [104](#)

## O

offset nulling [103](#)

Open Layers Control panel [34](#)

Open Layers Control Panel applet [131](#)

operation modes

  continuous analog input (scan mode) [105](#)

  single-value analog input [105](#)

## P

physical specifications [146](#), [148](#)

pin assignments

  analog input connector [152](#)

  external trigger and tachometer connector [154](#)

  external USB connector [155](#)

  STP STRAIN 120 accessory [157](#)

  STP STRAIN 350 accessory [157](#)

  STP STRAIN accessory [157](#)

  Sync Bus connector [153](#)

post-trigger acquisition mode [119](#)

post-trigger scan count [125](#)

power [29](#)

power specifications [146](#), [148](#)

power supply [29](#)

pressure transducers [66](#), [99](#)

## Q

Quarter-Bridge configuration

  wiring [42](#)

Quarter-Bridge Temp Comp configuration [93](#)

  wiring [47](#)

QuickDAQ [72](#)

  Advanced FFT Analysis option [17](#)

  Base version [16](#)

  FFT Analysis option [16](#)

## R

ranges

  analog input [104](#)

  number of [122](#)

reference trigger [108](#)

related documents [10](#)

remote sensing [100](#)

  Full-Bridge Axial Poisson configuration [64](#)

  Full-Bridge Bending configuration [59](#)

  Full-Bridge Bending Poisson configuration [61](#)

  Half-Bridge Bending configuration [55](#)

  Half-Bridge Poisson configuration [52](#)

  Quarter-Bridge configuration [45](#)

- Quarter-Bridge Temp Comp configuration [48](#)
- resolution
  - analog input [104](#)
  - available [122](#)
  - number of [122](#)
- retrigger clock frequency [120](#)
- returning modules to the factory [133](#)
- RJ45 connector
  - pin assignments [153](#)
- RJ50 cables [20](#), [41](#)
- RJ50 connector [39](#)
- RMA [133](#)
- rosette [43](#)

## S

- sample rate [106](#)
- scan count, post-trigger [125](#)
- scan operations, analog input [105](#)
- SDK [17](#)
- sensing [100](#)
- sensors [66](#), [99](#)
- shunt calibration [101](#), [124](#)
  - Full-Bridge Axial Poisson configuration [59](#), [65](#), [103](#)
  - Full-Bridge Bending configuration [59](#), [103](#)
  - Full-Bridge Bending Poisson configuration [59](#), [62](#), [103](#)
  - Half-Bridge Bending configuration [56](#), [102](#)
  - Half-Bridge Poisson configuration [53](#), [102](#)
  - Quarter-Bridge configuration [46](#), [102](#)
  - Quarter-Bridge Temp Comp configuration [49](#), [102](#)
- simultaneous clocking [126](#)
- simultaneous sample-and-hold support [121](#)
- simultaneous start list [119](#)
- single buffer [120](#)
- single channel analog input [91](#)
- single-value operations [119](#)
  - analog input [105](#)
- size, module [146](#)
- software trigger [107](#), [124](#), [125](#)
- specifications [141](#)
  - analog input [142](#), [143](#)
  - environmental [146](#), [148](#)
  - external power supply [149](#)
  - physical [146](#), [148](#)
  - power [146](#), [148](#)
  - regulatory [147](#)
  - tachometer input [144](#)
  - triggers [145](#)
- start trigger sources [107](#)
- stopping an operation [106](#)
- STP STRAIN 120 quarter-bridge completion
  - accessory [19](#), [40](#)
  - connector [157](#)
- STP STRAIN 350 quarter-bridge completion
  - accessory [20](#), [40](#)
  - connector [157](#)
- STP STRAIN general-purpose accessory [19](#), [40](#)
  - connector [157](#)
- strain gage channels
  - configurations [124](#)
  - support [124](#)
- strain gage measurement example [76](#)
- StrainGageBridgeConfiguration [124](#)
- SupportedGains [121](#)
- SupportedResolutions [122](#)
- SupportedThresholdTriggerChannels [125](#)
- SupportedVoltageRanges [122](#)
- SupportsBinaryEncoding [120](#)
- SupportsBridge [124](#)
- SupportsBuffering [120](#)
- SupportsContinuous [119](#)
- SupportsDifferential [121](#)
- SupportsExternalClock [126](#)
- SupportsFallingEdge [128](#)
- SupportsInProcessFlush [120](#)
- SupportsInternalClock [126](#)
- SupportsInternalExcitationVoltage [124](#)
- SupportsNegExternalTTLTrigger [125](#)
- SupportsNegThresholdTrigger [125](#)
- SupportsPosExternalTTLTrigger [125](#)
- SupportsPosThresholdTrigger [125](#)
- SupportsPostTriggerScanCount [125](#)
- SupportsRisingEdge [128](#)
- SupportsShuntCalibration [124](#)
- SupportsSimultaneousClocking [126](#)
- SupportsSimultaneousSampleHold [121](#)
- SupportsSimultaneousStart [119](#)
- SupportsSingleValue [119](#)
- SupportsSoftwareTrigger [125](#)
- SupportsStaleDataFlag [128](#)
- SupportsStrainGage [124](#)
- SupportsSyncBusTrigger [125](#)
- SupportsSynchronization [119](#)
- SupportsWrapSingle [120](#)
- Sync Bus connector pin assignments [153](#)
- Sync Bus reference trigger [125](#)
- Sync Bus trigger [108](#)
- synchronization modes [119](#)
- SynchronizationMode [119](#)

synchronizing tachometer and analog input data  
104  
system requirements 28

## T

tachometer  
falling edges 110, 128  
rising edges 110, 128  
Stale data flag 110, 128  
tachometer connector 154  
tachometer input 110  
specifications 144  
wiring 69  
technical support 132  
TEDS 103  
threshold trigger 107, 108  
channels 125  
negative 125  
positive 125  
throughput  
maximum 126  
minimum 126  
torque sensors 66, 99  
trademark and copyright information 2  
transducers 66, 99  
Trigger LED 31, 107  
triggered scan  
number of scans per trigger 120  
retrigger frequency 120  
triggers  
analog input 107  
external 107, 108  
external negative digital 125  
external positive digital 125  
negative threshold 125  
positive threshold 125  
software 107, 124, 125  
specifications 145  
Sync Bus 108, 125  
threshold 107, 108  
troubleshooting  
procedure 130  
technical support 132  
troubleshooting table 130  
TTL trigger 107, 108

## U

unpacking 27  
USB cable 31, 32

USB expansion hub 32  
USB LED 31, 32, 107

## V

Visual Basic for .NET programs 17  
Visual C# programs 17  
voltage ranges 104, 122  
number of 122

## W

wiring  
external trigger input 70  
Full-Bridge Axial Poisson configuration 63  
Full-Bridge Bending configuration 57  
Full-Bridge Bending Poisson configuration 60  
Half-Bridge Bending configuration 54  
Half-Bridge Poisson configuration 50  
load cells 66  
Quarter-Bridge configuration 42  
Quarter-Bridge Temp Comp configuration 47  
tachometer input 69  
voltage inputs 68  
wiring recommendations 38  
writing programs in  
C/C++ 17  
Visual Basic .NET 17  
Visual C# 17

