

CIO-DAS802/16

Analog Input and Digital I/O

User's Guide



**MEASUREMENT
COMPUTING™**

Document Revision 5A, March, 2010
© Copyright 2010, Measurement Computing Corporation

Trademark and Copyright Information

Measurement Computing Corporation, InstaCal, Universal Library, and the Measurement Computing logo are either trademarks or registered trademarks of Measurement Computing Corporation. Refer to the Copyrights & Trademarks section on mccdaq.com/legal for more information about Measurement Computing trademarks. Other product and company names mentioned herein are trademarks or trade names of their respective companies.

© 2010 Measurement Computing Corporation. All rights reserved. No part of this publication may be reproduced, stored in a retrieval system, or transmitted, in any form by any means, electronic, mechanical, by photocopying, recording, or otherwise without the prior written permission of Measurement Computing Corporation.

Notice

Measurement Computing Corporation does not authorize any Measurement Computing Corporation product for use in life support systems and/or devices without prior written consent from Measurement Computing Corporation. Life support devices/systems are devices or systems that, a) are intended for surgical implantation into the body, or b) support or sustain life and whose failure to perform can be reasonably expected to result in injury. Measurement Computing Corporation products are not designed with the components required, and are not subject to the testing required to ensure a level of reliability suitable for the treatment and diagnosis of people.

Table of Contents

Preface

About this User's Guide	6
What you will learn from this user's guide	6
Conventions in this user's guide	6
Where to find more information	6

Chapter 1

Introducing the CIO-DAS802/16.....	7
Overview: CIO-DAS802/16 features	7
Software features	7

Chapter 2

Installing the CIO-DAS802/16.....	8
What comes with your CIO-DAS802/16 shipment?	8
Hardware	8
Additional documentation	8
Optional components.....	8
Unpacking the CIO-DAS802/16	9
Installing the software	9
Configuring the CIO-DAS802/16	9
Base address switch	9
Input configuration	10
Interrupt level	12
Wait state jumper	12
Installing the CIO-DAS802/16.....	13
Connecting the board for I/O operations	13
Connectors, cables – main I/O connector	13
Field wiring, signal termination, and conditioning	14

Chapter 3

Functional Details	15
Analog inputs	15
Single-ended inputs.....	15
Floating differential	15
Fully differential	15
Digital inputs and outputs.....	16
Pacer/counter/timer circuit	16

Chapter 4

Specifications.....	18
Analog input.....	18
Digital input/output	19
Counters.....	19
Power consumption	19
Environmental	20
Main connector and pin out.....	20

Declaration of Conformity.....	21
---------------------------------------	-----------

About this User's Guide

What you will learn from this user's guide

This user's guide explains how to install, configure, and use the CIO-DAS802/16 board so that you get the most out of its analog input and digital I/O features. This user's guide also refers you to related documents available on our web site, and to technical support resources.

Conventions in this user's guide

The following conventions are used in this manual to convey special information:

For more information on ...

Text presented in a box signifies additional information and helpful hints related to the subject matter you are reading.

Caution! Shaded caution statements present information to help you avoid injuring yourself and others, damaging your hardware, or losing your data.

<#:#> Angle brackets that enclose numbers separated by a colon signify a range of numbers, such as those assigned to registers, bit settings, etc.

bold text **Bold** text is used for the names of objects on the screen, such as buttons, text boxes, and check boxes. For example:
1. Insert the disk or CD and click the **OK** button.

italic text *Italic* text is used for the names of manuals and help topic titles, and to emphasize a word or phrase. For example:
The *InstaCal* installation procedure is explained in the *Quick Start Guide*.
Never touch the exposed pins or circuit connections on the board.

Where to find more information

For additional information relevant to the operation of your hardware, refer to the *Documents* subdirectory where you installed the MCC DAQ software (C:\Program Files\Measurement Computing\DAQ by default), or search for your device on our website at www.mccdaq.com.

If you need to program at the register level in your application, refer to the *Register Map for the CIO-DAS802/16*. This document is available on our website at www.mccdaq.com/registermaps/RegMapCIO-DAS802-16.pdf.

Introducing the CIO-DAS802/16

Overview: CIO-DAS802/16 features

The CIO-DAS802/16 is an extension of the popular CIO-DAS08 architecture. The CIO-DAS802/16 has a set of registers identical to the CIO-DAS08, and an additional set of registers for the extended features. Software written for the DAS08 will work without modification, but will not provide access to the extended features. The connector is nearly identical to the CIO-DAS08, and more closely resembles the CIO-DAS08-PGA.

The CIO-DAS802/16 provides eight channels of 16-bit analog input, seven digital I/O, and three 16-bit down counters.

You can configure each analog channel for differential or single-ended input using a bank of on-board switches. Input ranges are software-selectable as either bipolar or unipolar:

- Bipolar: ± 10 V, ± 5 V, ± 2.5 V, and ± 1.25 V
- Unipolar: 0 to 10 V, 0 to 5 V, 0 to 2.5 V, and 0 to 1.25 V

The digital channels are TTL level. Three digital channels are configured as inputs, and four channels are configured as outputs. The DOUT1 through DOUT4 can be used to control external EXP boards. DIN1 can be used to trigger and gate A/D conversions.

The CIO-DAS802/16 provides a 100 kHz sample rate.

You can set an interrupt level for the CIO-DAS802/16, and enable a wait state generator with on-board jumpers.

Software features

For information on the features of *InstaCal* and the other software included with your CIO-DAS802/16, refer to the *Quick Start Guide* that shipped with your device.

Installing the CIO-DAS802/16

What comes with your CIO-DAS802/16 shipment?

The following items are shipped with the CIO-DAS802/16.

Hardware

- CIO-DAS802/16

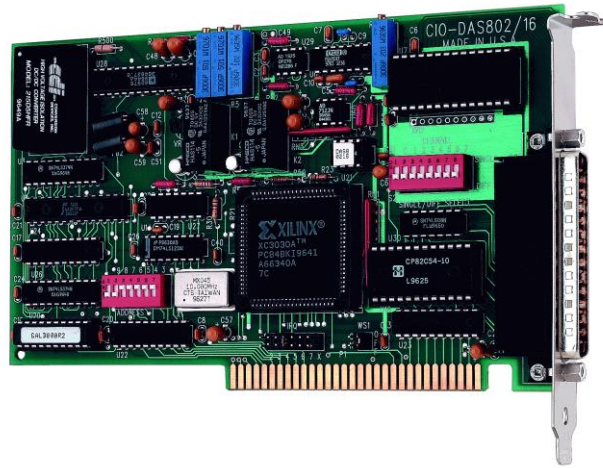

Additional documentation

In addition to this hardware user's guide, you should also receive the *Quick Start Guide* (available in PDF at www.mccdaq.com/PDFmanuals/DAQ-Software-Quick-Start.pdf). This booklet supplies a brief description of the software you received with your CIO-DAS802/16 and information regarding installation of that software. Please read this booklet completely before installing any software or hardware.

Optional components

You can also order the following MCC product to use with your CIO-DAS802/16.

- C37FF-x cable



- Signal termination and conditioning accessories
MCC provides signal conditioning and termination products for use with the CIO-DAS802/16. Refer to [Field wiring, signal termination, and conditioning](#) on page 14 for a complete list of compatible accessory products.

Unpacking the CIO-DAS802/16

As with any electronic device, you should take care while handling to avoid damage from static electricity. Before removing the CIO-DAS802/16 from its packaging, ground yourself using a wrist strap or by simply touching the computer chassis or other grounded object to eliminate any stored static charge.

If any components are missing or damaged, notify Measurement Computing Corporation immediately by phone, fax, or e-mail:

- Phone: 508-946-5100 and follow the instructions for reaching Tech Support.
- Fax: 508-946-9500 to the attention of Tech Support
- Email: techsupport@mccdaq.com

Installing the software

Refer to the *Quick Start Guide* for instructions on installing the software on the *Measurement Computing Data Acquisition Software CD*. This booklet is available in PDF at www.mccdaq.com/PDFmanuals/DAQ-Software-Quick-Start.pdf.

Configuring the CIO-DAS802/16

The CIO-DAS802/16 has two banks of switches and two jumpers which you must set before installing the board in your computer. The *InstaCal* calibration and test program included with the CIO-DAS802/16 will show you how to configure the board. Run *InstaCal* before you open your computer and install the board. The CIO-DAS802/16 is shipped with the factory-default settings listed below.

Factory-configured default settings

Switch/jumper description	Default setting
Base address DIP switch	300h (768 decimal)
Input configuration DIP switch	Differential
Interrupt level select jumper	X (no interrupt level set)
Wait State jumper	Off (disabled)

Before installing the CIO-DAS802/16, verify that the board is configured with the settings that you want. Review the following information to change the default configuration of a jumper or switch on the CIO-DAS802/16 board.

Base address switch

Before you install the CIO-DAS802/16 in your computer, set the base address by using the dip switch labeled **ADDRESS** located on the board. The easiest way to set the base address switch is to let *InstaCal* show you the correct settings. However, if are already familiar with setting ISA base addresses, you may use the base address switch description below to guide your base address selection.

Unless there is already another board in your system using address 300 hex (768 decimal), leave the switches as they are set at the factory. The example shown in Figure 1 shows the settings for the factory-default base address of 300 hex.

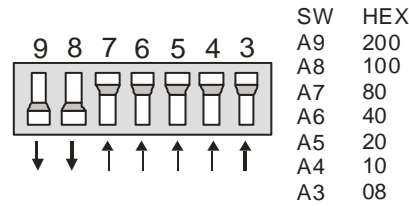

Figure 1. Base address switches

In the default configuration shown in Figure 1, addresses 9 and 8 are DOWN, and all others are UP. Address 9 = 200 hex (512 decimal) and address 8 = 100 hex (256 decimal); when added together they equal 300 hex (768 decimal).

Disregard the numbers printed on the switch

When setting the base address, refer to the numbers printed in white on the printed circuit board.

PC I/O addresses

Hex Range	Function	Hex Range	Function
000-00F	8237 DMA #1	2C0-2CF	EGA
020-021	8259 PIC#1	2D0-2DF	EGA
040-043	8253 Timer	2E0-2E7	GPIB (AT)
060-063	8255 PPI (XT)	2E8-2EF	Serial Port
060-064	8742 Controller (AT)	2F8-2FF	Serial Port
070-071	CMOS RAM & NMI mask (AT)	300-30F	Prototype card
080-08F	DMA page registers	310-31F	Prototype card
0A0-0A1	8259 PIC #2 (AT)	320-32F	Hard disk (XT)
0A0-0AF	NMI mask (XT)	378-37F	Parallel printer
0C0-0DF	8237 #2 (AT)	380-38F	SDLC
0F0-0FF	80287 numeric CO-P (AT)	3A0-3AF	SDLC
1F0-1FF	Hard disk (AT)	3B0-3BB	MDA
200-20F	Game control	3BC-3BB	Parallel printer
210-21F	Expansion unit (XT)	3C0-3CF	EGA
238-23B	Bus mouse	3D0-3DF	CGA
23C-23F	ALT bus mouse	3E8-3EF	Serial port
270-27F	Parallel printer	3F0-3F7	Floppy disk
2B0-2BF	EGA	3F8-3FF	Serial port

Input configuration

You can configure each analog channel for differential or single-ended input. You can set the input of each channel using the bank of switches labeled **S2** (0 through 7) on the board. These switches correspond to channels 0 to 7 of the analog inputs.

The switches are set by default for differential input. Differential inputs are 3-wire analog hookups consisting of a signal high, signal low and chassis ground. The benefits of differential inputs are the ability to reject noise which affects both signal high and low, and the ability to compensate for ground loops or potentials between signal low and chassis ground.

Although differential inputs are often preferable to single ended inputs, the floating nature of a differential input can make getting an accurate reading difficult. In those cases, the CIO-DAS802/16 inputs can be converted to single-ended or modified differential.

The CIO-EXP16 and CIO-EXP32 were designed to interface to a single-ended input. Failure to set the switches to single-ended when an EXP is connected results in floating, unstable readings from the EXP.

There are two ways to configure the analog inputs:

- Set the bank of eight DIP switches on the jumper block labeled S2 located near the I/O connector. Position the switches in the OFF position (down) to configure the input for differential mode (default). Position the switches in the ON position (up) to configure the input for single-ended mode.

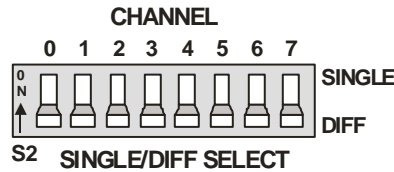

Figure 2. Input configuration jumpers

Figure 3 shows one analog input and the single-ended / differential switch.

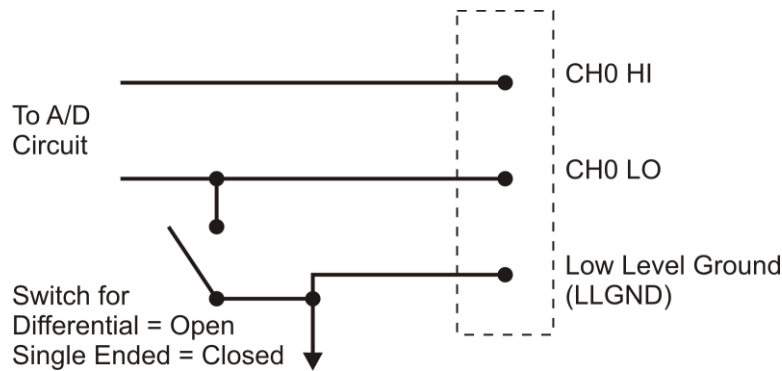

Figure 3. Input configuration switch

- You can also install an SIP resistor pack at position RN2 to convert the inputs to single-ended. This package of 10K resistors provides a reference to ground for each of the eight Low Input lines. This type of input behaves like a single-ended input since there is a reference to ground and floating sources may be measured.

Figure 4 shows one analog input line with the SIP resistor installed. When the SIP resistor package is installed, all eight analog inputs are single-ended.

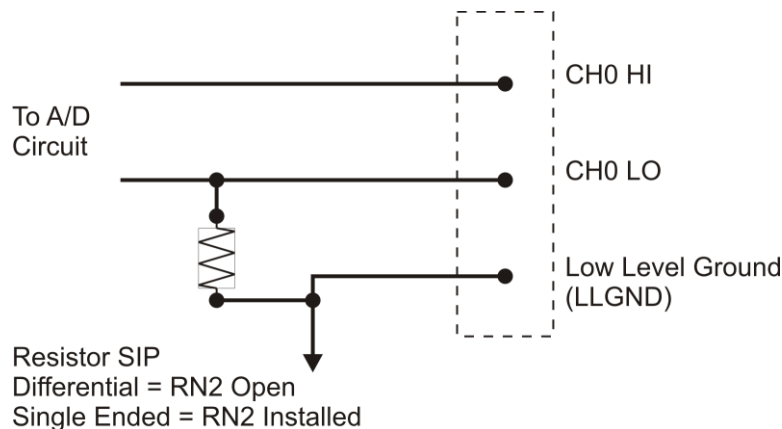

Figure 4. Analog input configuration

Note: If you are using an EXP board with the CIO-DAS802/16, do not install the SIP resistor. Set the input configuration switch to single-ended for both the EXP channel and the CJC channel.

Interrupt level

In order to take advantage of high speed transfers, you must provide the board with an interrupt that is not used by other devices in your computer. Use the jumper block labeled IRQ (above the PC bus interface) to select an interrupt level between 2 and 7, or to disable interrupts (X). By default, the board is shipped with no interrupt level set (the jumper is in the 'X' position) – see Figure 5.

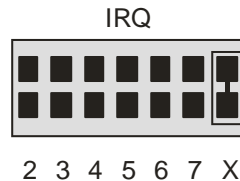

Figure 5. Interrupt level select jumper

Set the interrupt level jumper if your software requires it. The Universal Library and other programs which take advantage of the REP-INSW high speed transfer capability of the board require an interrupt. If you set the interrupt jumper, check your PC's current configuration for interrupt conflicts. Refer to the table below for typical IRQ assignments.

IRQ assignments

Name	Description	Name	Description
NMI	Parity	IRQ8	Real Time Clock (AT)
IRQ0	Timer	IRQ9	Re-Directed to IRQ2 (AT)
IRQ1	Keyboard	IRQ10	Unassigned
IRQ2	Reserved (XT) INT 8-15 (AT)	IRQ11	Unassigned
IRQ3	COM OR SDLC	IRQ12	Unassigned
IRQ4	COM OR SDLC	IRQ13	80287 Numeric CO-P
IRQ5	Hard Disk (XT) LPT (AT)	IRQ14	Hard Disk
IRQ6	Floppy Disk	IRQ15	Unassigned
IRQ7	LPT	Note: IRQ8-15 are AT only	

Wait state jumper

Enable the wait state jumper if you have a computer with an I/O bus transfer rate which is too fast for the CIO-DAS802/16, or if the board fails sporadically in random ways.

To enable the wait state, set the jumper labeled **WS1** to the ON position. Enabling the wait state causes the personal computer's bus transfer rate to slow down whenever the CIO-DAS802/16 is written to or read from. This jumper is shown in Figure 6 configured for OFF (wait state is disabled).

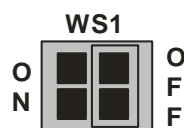

Figure 6. Wait State jumper

The wait state generator on the CIO-DAS802/16 is only active when the CIO-DAS802/16 is being accessed. Your PC will not be slowed down in general by using the wait state.

Installing the CIO-DAS802/16

After you configure the board's switches and jumpers, you can install the CIO-DAS802/16 into your computer. To install your board, follow the steps below.

Install the MCC DAQ software before you install your board

The driver needed to run your board is installed with the MCC DAQ software. Therefore, you need to install the MCC DAQ software before you install your board. Refer to the *Quick Start Guide* for instructions on installing the software.

1. Turn your computer off, open it up, and insert your board into an available ISA slot.
2. Close your computer and turn it on.
3. To test your installation and configure your board, run the *InstaCal* utility you installed in the previous section. Refer to the *Quick Start Guide* that came with your board www.mccdaq.com/PDFmanuals/DAQ-Software-Quick-Start.pdf for information on how to initially set up and load *InstaCal*.

Connecting the board for I/O operations

Connectors, cables – main I/O connector

The table below lists the board connector, applicable cables, and compatible accessory products.

Board connector, cables, and accessory equipment

Connector type	37-pin D type connector
Compatible cable	C37FF-x
Compatible accessory products with the C37FF-x cable	CIO-MINI37 CIO-TERMINAL CIO-EXP16 CIO-EXP32 ISO-RACK08
Connector type	37-pin D type connector

Information on signal connections

General information regarding signal connection and configuration is available in the *Guide to Signal Connections* (available at www.mccdaq.com/signals/signals.pdf).

Pinout – main I/O connector

The CIO-DAS802/16 I/O connector is a standard 37-pin male D connector that is accessible from the rear of the computer through the expansion backplate.

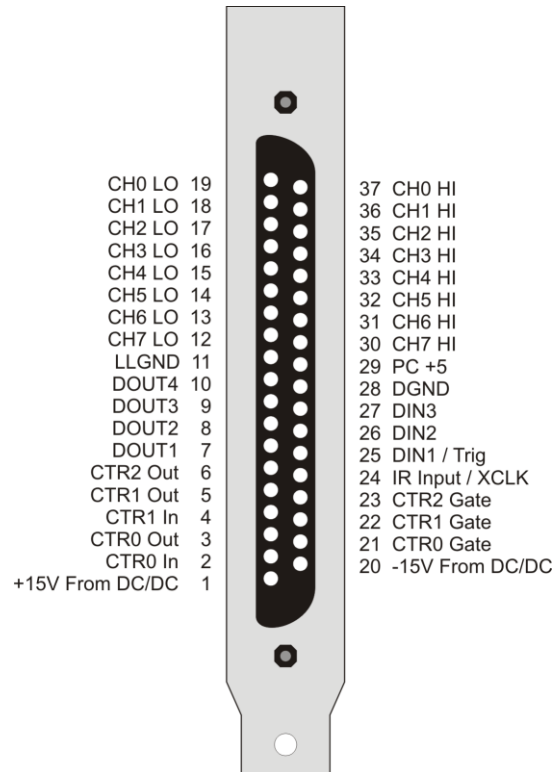

Figure 7. I/O connector pin-out

Field wiring, signal termination, and conditioning

You can use the following cabling, screw termination, and signal conditioning products with the CIO-DAS802/16.

- CIO-MINI37 – 37-pin screw terminal board.
- CIO-TERMINAL – 37-pin screw terminal board with on-board prototyping area.

Details on these products are available on our web site at

www.mccdaq.com/products/screw_terminal_bnc.aspx.

- CIO-EXP16 – 16-channel analog multiplexer board with on-board CJC sensor.
- CIO-EXP32 – 32-channel analog multiplexer board with on-board CJC sensor and 2 Gain amps.
- ISO-RACK08 – Isolated 8-channel, 5B module rack for analog signal conditioning and expansion.

Details on these products are available on our web site at www.mccdaq.com/products/signal_conditioning.aspx.

Functional Details

Analog inputs

Analog inputs on the CIO-DAS802/16 are designed to accept voltage signals for measurement.

The analog inputs may be configured in three different ways:

- True differential inputs; for sources with a separate ground, common to the PC.
- Pseudo-differential inputs used for floating sources has noise rejection capability
- Single ended inputs; also used for floating sources.

Caution! Using a voltmeter, measure the AC and DC voltage between the ground signal at the signal source and the PC. Place the red probe on the PC ground and the black probe on the signal ground. If there is more than 10 volts, do not connect the CIO-DAS802/16 to this signal source because you will not be able to make any reading. If there is more than 30 volts, DO NOT connect this signal to the board because it will damage the board and possibly the computer. Use great care when measuring any voltage. Voltages over 30 V can be dangerous to your health.

Single-ended inputs

A single ended input is two wires connected to the CIO-DAS802/16; a channel high (CH# HI) and a Low level ground (LLGND). The LLGND signal *must be the same ground the PC is on*. The CH# HI is the signal voltage. Single-ended mode is selected via switch S2 on the board (refer to Input configuration on page 10 for more information.)

Floating differential

A floating differential input is two wires from the signal source and a 10K ground reference resistor installed at the CIO-DAS802/16 input. The two signals from the signal source are Signal High (CH# HI) and Signal Low (CH# LO). The reference resistor is connected between the CIO-DAS802/16 CH# LO and LLGND pins. This is accomplished with the installation of the SIP resistor pack.

A floating differential hookup is handy when the signal source is floating with respect to ground, such as a battery, 4-20 mA transmitter or if the lead lengths are long or subject to EMI interference. The floating differential input will reject up to 10 V of EMI on the signal wires.

Caution! Verify that the signal source really floating. Check it with an ohmmeter before risking the CIO-DAS802/16 and the PC.

Fully differential

A differential signal has three wires from the signal source. The signals are Signal High (CH# HI), Signal Low (CH# LO) and Signal Ground (LLGND).

A differential connection allows you to connect the CIO-DAS802/16 to a signal source with a ground that is different than the PC ground, but less than 10 V difference, and still make a true measurement of the signal between CH# HI and CH# LO.

Example: A laboratory instrument with its own wall plug. There are sometimes voltage differences in wall GND between outlets.

Digital inputs and outputs

All the digital inputs and outputs on the CIO-DAS802/16 are TTL level. TTL is an electronics industry term, short for Transistor Transistor Logic, which describes a standard for digital signals which are either at TTL low or TTL high; levels which are detected by all other TTL devices.

The CIO-DAS802/16 has three digital inputs and four digital outputs. The digital inputs are buffered by a register on the board. Each time the register is read, the current high/low state of the digital I/O lines is obtained. The digital outputs are controlled by a register on the board and are updated each time the register is written to. The lines are pulled high so a logical-one is read if no signal is connected to an input.

The digital lines also are used to control external EXP boards (all four outputs) and to trigger and gate A/D conversions (DIn 1).

Pacer/counter/timer circuit

The CIO-DAS802/16 has an 82C54 counter timer which can be used to perform the following tasks:

- Pace analog conversions
- Measure frequency
- Count events
- Time intervals

The software to support the timer is in the Universal Library. The connections to the hardware are explained here. For detailed information on the 82C54 registers, refer to the 82C54 data sheet at www.mccdaq.com/PDFmanuals/82C54.pdf.

The 82C54 contains three 16-bit counters (CTR0, CTR1, and CTR2). CTR1 and CTR2 are dedicated to the pacing of analog to digital conversions. CTR1 and CTR2 are available for other tasks when not in use by the A/D, but are limited to some extent by the wiring and access to I/O pins. CTR0 is available for your use.

Figure 8 shows the connections to the counters. It also shows the 82C54 functions, I/O pins and how these are connected on the CIO-DAS802/16.

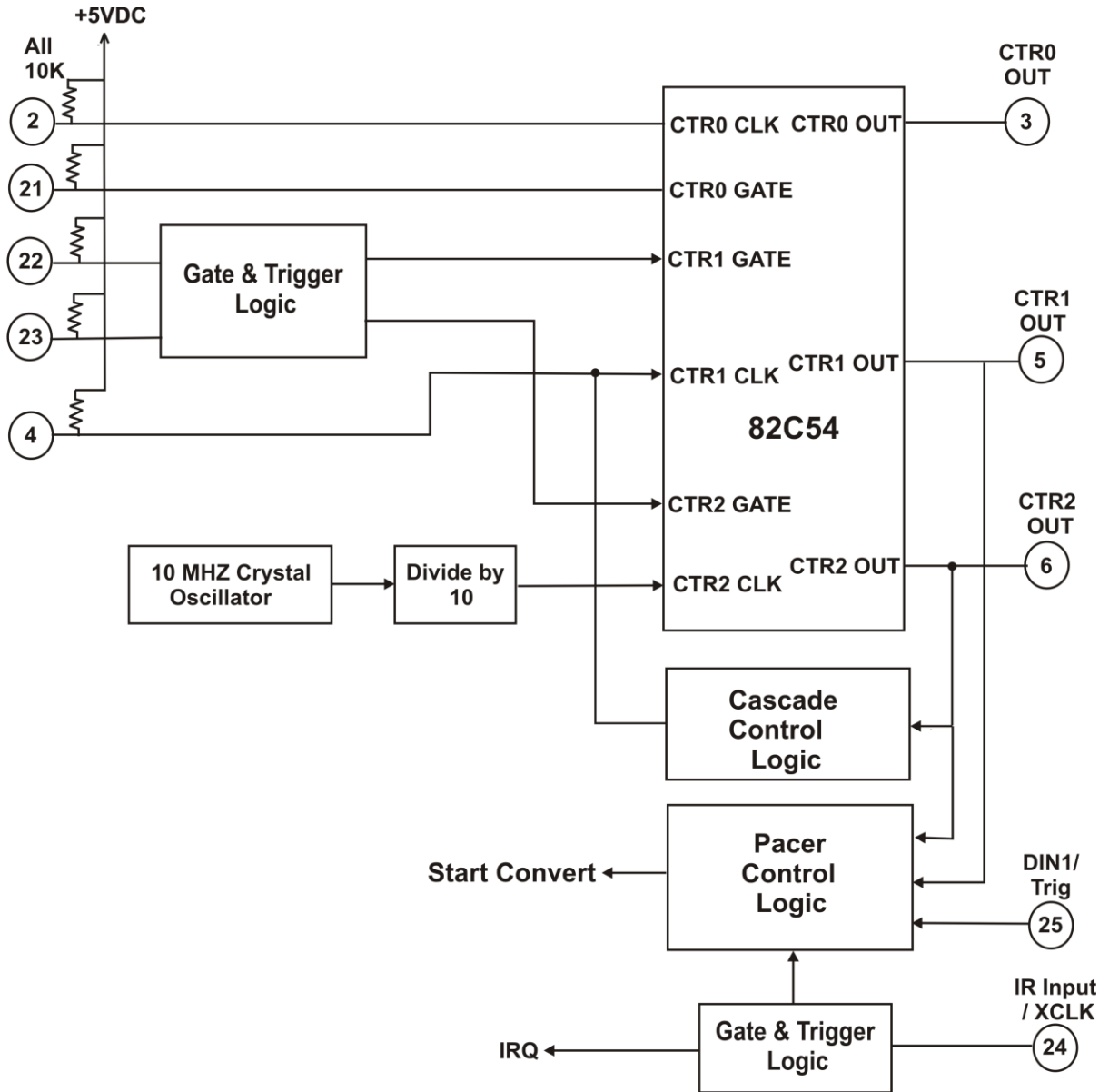

Figure 8. Pacer/counter/timer block diagram

Specifications

All specifications are subject to change without notice.

Typical for 25°C unless otherwise specified.

Specifications in *italic text* are guaranteed by design.

Analog input

Table 1. Analog input specifications

Parameter	Specification
<i>A/D converter type</i>	<i>AD7805PB, successive approximation</i>
Resolution	16 bits
Number of channels	8
Input ranges	$\pm 10\text{ V}$, $\pm 5\text{ V}$, $\pm 2.5\text{ V}$, $\pm 1.25\text{ V}$, 0 to 10 V, 0 to 5 V, 0 to 2.5 V, 0 to 1.25 V
Polarity	Unipolar/Bipolar programmable, 11 ms max switching delay
A/D pacing	Programmable: internal counter external source (IR Input / XCLK, falling edge) software polled
A/D trigger sources	External hardware(DIN1 / Trig, rising edge)
Data transfer	Interrupt or software polled from 256 sample FIFO buffer
Channel configuration	Differential (or pseudo-differential with installation of a SIP resistor) or single-ended, switch selectable for each channel
DMA	None
A/D conversion time	10 μs (including signal acquisition time)
Throughput	100 kHz
Accuracy	$\pm 0.0015\%$ of reading $\pm 1.5\text{ LSB}$
Differential linearity error	$+1.5/-1\text{ LSB max}$
Integral linearity error	$\pm 1.5\text{ LSB max}$
No missing codes (guaranteed)	16 bits
Gain drift (A/D specs)	$\pm 10\text{ ppm}/^\circ\text{C}$
Zero drift (A/D specs)	$\pm 5\text{ ppm}/^\circ\text{C}$
Common mode range	$\pm 10\text{ V}$
CMRR @ 60 Hz	90 dB min
<i>Input leakage current (@ 25 °C)</i>	<i>100 nA</i>
<i>Input impedance</i>	<i>10 Mohms</i>
<i>Absolute maximum input voltage</i>	<i>$\pm 35\text{ V}$</i>
Noise distribution (results presented as Average % ± 2 bins, Average % ± 1 bin, Average # bins)	
Bipolar	10 V 98% / 85% / 9 bins
	5 V, 2.5 V 98% / 80% / 9 bins
	1.25 V 95% / 75% / 10 bins
Unipolar	10 V, 5 V 85% / 65% / 12 bins
	2.5 V, 1.25 V 85% / 60% / 14 bins

Digital input/output

Table 2. Digital I/O specifications

<i>Digital type</i>	<i>Output:</i> FPGA <i>Input:</i> 74LS08
Configuration	Two ports, 3 input and 4 output
<i>Input low voltage</i>	0.8 V max
<i>Input high voltage</i>	2.0 V min
<i>Output low voltage (IOL = 8 mA)</i>	0.25 V typical, 0.4 V max
<i>Output high voltage (IOH = -0.4 mA)</i>	3.4 V typical, 2.7 V min
<i>Absolute maximum input voltage</i>	-0.5 V, +5.5 V
Interrupts	Jumper selectable: levels 2, 3, 4, 5, 6, 7. Positive edge triggered
Interrupt enable	Programmable
Interrupt sources	External (IR In / XCLK), A/D End-of-conversion, A/D FIFO-half-full

Counters

Table 3. Counter specifications

Counter type	82C54
Configuration	3 down counters , 16 bit resolution
Counter 0 — Independent user counter	Source: External, user connector (CTR0 In) Gate: External, user connector (CTR0 Gate) Output: User connector (CTR0 Out)
Counter 1 — ADC Pacer Lower Divider or independent user counter	Source: User connector (CTR1 In) and optionally, CTR2 Out, selectable by software Gate: Programmable, disabled or user connector (CTR1 Gate). Output: User connector (CTR1 Out) and optionally to A/D start convert, software selectable
Counter 2 — ADC Pacer Upper Divider	Source: Internal 1 MHz oscillator Gate: Programmable, disabled or user connector (CTR 2 Gate) Output: User connector (CTR2 Out) and optionally to CTR1 input, software selectable
<i>Clock input frequency</i>	10 MHz max
<i>High pulse width (clock input)</i>	30 ns min
<i>Low pulse width (clock input)</i>	50 ns min
<i>Gate width high</i>	50 ns min
<i>Gate width low</i>	50 ns min
<i>Input low voltage</i>	0.8 V max
<i>Input high voltage</i>	2.0 V min
<i>Output low voltage</i>	0.4 V max
<i>Output high voltage</i>	3.0 V min

Power consumption

Table 4. Power consumption specifications

+5V quiescent	430 mA typical, 675 mA max
---------------	----------------------------

Environmental

Table 5. Environmental specifications

<i>Operating temperature range</i>	<i>0 to 50 °C</i>
<i>Storage temperature range</i>	<i>-20 to 70 °C</i>
<i>Humidity</i>	<i>0 to 90% non-condensing</i>

Main connector and pin out

Table 6. Main connector specifications

Connector type	37-pin D type connector
Compatible cable	C37FF-x
Compatible accessory products with the C37FF-x cable	CIO-MINI37 CIO-TERMINAL CIO-EXP16 CIO-EXP32 ISO-RACK08

Table 7. Single-ended mode pin out

Pin	Signal Name	Pin	Signal Name
1	+15V from DC/DC	20	-15V from DC/DC
2	CTR0 In	21	CTR0 Gate
3	CTR0 Out	22	CTR1 Gate
4	CTR1 In	23	CTR2 Gate
5	CTR1 Out	24	IR Input/XCLK
6	CTR2 Out	25	DIN1 /Trig
7	DOUT1	26	DIN2
8	DOUT2	27	DIN3
9	DOUT3	28	DGND
10	DOUT4	29	PC +5V
11	LLGND	30	CH7 HI
12	CH7 LO	31	CH6 HI
13	CH6 LO	32	CH5 HI
14	CH5 LO	33	CH4 HI
15	CH4 LO	34	CH3 HI
16	CH3 LO	35	CH2 HI
17	CH2 LO	36	CH1 HI
18	CH1 LO	37	CH0 HI
19	CH0 LO		

CE Declaration of Conformity

Manufacturer: Measurement Computing Corporation
Address: 10 Commerce Way
Suite 1008
Norton, MA 02766
USA

Category: Electrical equipment for measurement, control and laboratory use.

Measurement Computing Corporation declares under sole responsibility that the product

CIO-DAS802/16

to which this declaration relates is in conformity with the relevant provisions of the following standards or other documents:

EU EMC Directive 89/336/EEC: Electromagnetic Compatibility, EN55022 (1987), EN50082-1

Emissions: Group 1, Class B

- EN55022 (1987): Radiated and Conducted emissions.

Immunity: EN50082-1

- IEC 801-2 (1987): Electrostatic Discharge immunity, Criteria A.
- IEC 801-3 (1984): Radiated Electromagnetic Field immunity Criteria A.
- IEC 801-4 (1988): Electric Fast Transient Burst immunity Criteria A.

Declaration of Conformity based on tests conducted by Chomerics Test Services, Woburn, MA 01801, USA in November, 1995. Test records are outlined in Chomerics Test Report #EMI0168A.95.

We hereby declare that the equipment specified conforms to the above Directives and Standards.



Carl Haapaoja, Director of Quality Assurance

Measurement Computing Corporation
10 Commerce Way
Suite 1008
Norton, Massachusetts 02766
(508) 946-5100
Fax: (508) 946-9500
E-mail: info@mccdaq.com
www.mccdaq.com