

CIO-DAS16Jr/16

USER'S MANUAL



**MEASUREMENT
COMPUTING™**

Revision 4
March, 2001

LIFETIME WARRANTY

Every hardware product manufactured by Measurement Computing Corp. is warranted against defects in materials or workmanship for the life of the product, to the original purchaser. Any products found to be defective will be repaired or replaced promptly.

LIFETIME HARSH ENVIRONMENT WARRANTY™

Any Measurement Computing Corp. product which is damaged due to misuse may be replaced for only 50% of the current price. I/O boards face some harsh environments, some harsher than the boards are designed to withstand. When that happens, just return the board with an order for its replacement at only 50% of the list price. Measurement Computing Corp. does not need to profit from your misfortune. By the way, we will honor this warranty for any other manufacture's board that we have a replacement for!

30 DAY MONEY-BACK GUARANTEE

Any Measurement Computing Corp. product may be returned within 30 days of purchase for a full refund of the price paid for the product being returned. If you are not satisfied, or chose the wrong product by mistake, you do not have to keep it. Please call for a RMA number first. No credits or returns accepted without a copy of the original invoice. Some software products are subject to a repackaging fee.

These warranties are in lieu of all other warranties, expressed or implied, including any implied warranty of merchantability or fitness for a particular application. The remedies provided herein are the buyer's sole and exclusive remedies. Neither Measurement Computing Corp., nor its employees shall be liable for any direct or indirect, special, incidental or consequential damage arising from the use of its products, even if Measurement Computing Corp. has been notified in advance of the possibility of such damages.

MEGA-FIFO, the CIO prefix to data acquisition board model numbers, the PCM prefix to data acquisition board model numbers, PCM-DAS08, PCM-D24C3, PCM-DAC02, PCM-COM422, PCM-COM485, PCM-DMM, PCM-DAS16D/12, PCM-DAS16S/12, PCM-DAS16D/16, PCM-DAS16S/16, PCI-DAS6402/16, Universal Library, *InstaCal*, *Harsh Environment Warranty* and Measurement Computing Corp. are registered trademarks of Measurement Computing Corp.

IBM, PC, and PC/AT are trademarks of International Business Machines Corp. Windows is a trademark of Microsoft Corp. All other trademarks are the property of their respective owners.

Information furnished by Measurement Computing Corp. is believed to be accurate and reliable. However, no responsibility is assumed by Measurement Computing Corp. neither for its use; nor for any infringements of patents or other rights of third parties, which may result from its use. No license is granted by implication or otherwise under any patent or copyrights of Measurement Computing Corp.

All rights reserved. No part of this publication may be reproduced, stored in a retrieval system, or transmitted, in any form by any means, electronic, mechanical, by photocopying, recording or otherwise without the prior written permission of Measurement Computing Corp.

Notice

Measurement Computing Corp. does not authorize any Measurement Computing Corp. product for use in life support systems and/or devices without the written approval of the President of Measurement Computing Corp. Life support devices/systems are devices or systems which, a) are intended for surgical implantation into the body, or b) support or sustain life and whose failure to perform can be reasonably expected to result in injury. Measurement Computing Corp. products are not designed with the components required, and are not subject to the testing required to ensure a level of reliability suitable for the treatment and diagnosis of people.

TABLE OF CONTENTS

1 INSTALLATION	1
1.1 BASE ADDRESS	1
1.2 DMA LEVEL SELECT	1
1.3 8 OR 16 CHANNEL SELECT	1
1.4 INSTALLING THE BOARD	2
2 SIGNAL CONNECTIONS	3
2.1 CONNECTOR DIAGRAM	3
2.2 ANALOG INPUTS	3
2.2.1 Single-Ended Inputs	4
2.2.2 Differential Inputs	4
2.2.3 System Grounds and Isolation	5
2.2.4 Determine Your Ground Type	5
2.2.5 Systems with Common Grounds	6
2.2.6 Systems with Common Mode (ground offset) Voltages	6
2.2.7 Small Common Mode Voltages	6
2.2.8 Large Common Mode Voltages	7
2.2.9 CIO-DAS16Jr/16 and Signal Source Have Isolated Grounds	7
2.3 WIRING CONFIGURATIONS	7
2.3.1 Common Ground / Single-Ended Inputs	8
2.3.2 Common Ground / Differential Inputs	8
2.3.3 Common Mode Voltage < +/-10V/Single-Ended Inputs	9
2.3.4 Common Mode Voltage < +/-10V/Differential Inputs	9
2.3.5 Common Mode Voltage > +/-10V	9
2.3.6 Isolated Grounds / Single-Ended Inputs	10
2.3.7 Isolated Grounds / Differential Inputs	10
3 REGISTER ARCHITECTURE	11
3.1 CONTROL & DATA REGISTERS	11
3.2 A/D DATA & CHANNEL REGISTERS	12
3.3 CHANNEL MUX SCAN LIMITS REGISTER	13
3.4 4-BIT DIGITAL I/O REGISTERS	13
3.5 STATUS REGISTER	14
3.6 DMA, INTERRUPT & TRIGGER CONTROL	14
3.7 PACER CLOCK CONTROL REGISTER	15
3.8 ANALOG INPUT RANGE REGISTER	16
3.9 PACER CLOCK DATA & CONTROL REGISTERS	16
3.10 ANALOG INPUT	17
3.11 DIGITAL INPUT & OUTPUT	17
3.12 OUTPUT	17
3.13 INPUT	17
4 SPECIFICATIONS	18

This page is blank.

1.1 SOFTWARE

Before installing the board, install and run *InstaCal*. This package is the installation, calibration and test utility included with your board. *InstaCal* will guide you through switch and jumper settings for your board. Detailed information regarding these settings can be found below. Refer to the *Software Installation* manual for *InstaCal* installation instructions.

The CIO-DAS16Jr/16 has one bank of base address-select switches and two single-function switches which must be set before installing the board in your computer.

1.2 BASE ADDRESS

Unless there is already a board in your system that uses address 300 hex (768 decimal), leave the switches as they were set at the factory. In the example shown in Figure 1-1, the board is set for base address 300h (768 decimal).

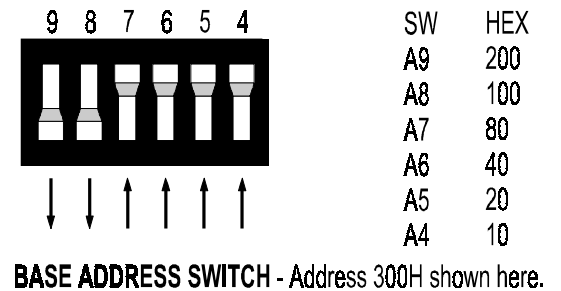

Figure 1-1 Base Address Switches

1.3 DMA LEVEL SELECT

The board is shipped with the DMA level switch set to DMA level 1. Unless you have another board in your system using DMA level 1, leave the DMA level switch in the level 1 position (Figure 1-2).

Some network boards use DMA and so do some IEEE-488 interface boards. If you suspect a conflict with another board in the system, change the switch to level 3.

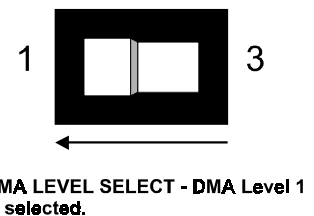

Figure 1-2. DMA Level Select Switch

1.4 8 or 16 CHANNEL SELECT

The analog inputs of the CIO-DAS16Jr/16 can be configured as 8 differential or 16 single-ended. Using differential inputs allows up to 10 volts of common mode (ground loop) rejection.

The CIO-DAS16Jr/16 comes from the factory configured for eight differential inputs. Set it for the number of inputs (and type) you require (Figure 1-3).

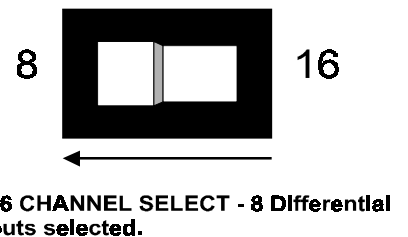

Figure 1-3. Channel Number Select Switch

1.5 INSTALLING THE BOARD

Having configured the board's switches and jumpers, it is now time to install the board into an ISA slot in the PC.

1. Turn the power off.
2. Remove the cover of your computer. Please be careful not to dislodge any of the cables installed on the boards in your computer as you slide the cover off.
3. Locate an empty ISA expansion slot in your computer.
4. Push the board firmly down into the expansion bus connector. If it is not seated fully it may fail to work and could short circuit the PC bus power onto a PC bus signal. This could damage the motherboard or the circuit board.
5. Turn the PC power back on and verify proper installation by running *InstaCal* Test (refer to the *Software Installation Manual* for information on running *InstaCal*).

2.1 CONNECTOR DIAGRAM

The CIO-DAS16Jr/16 analog connector is a male 37-pin, D-type connector accessible from the rear of the PC through the expansion backplate. The signals available are identical to the DAS-16, with the exception of pins 8, 9, 10 and 27 (D/A signals on the DAS-16, no-connect on the CIO-DAS16Jr/16). Another signal, SS&H OUT, can be accessed at pin 26.

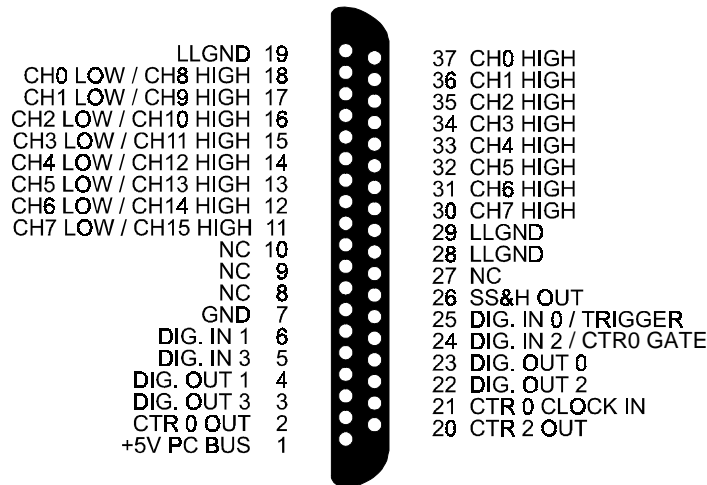

Figure 2-1. Connector Pin-Out

The connector (Figure 2-1) accepts female 37-pin D-type connectors, such as those on the C73FF-2, a 2-foot cable with connectors.

If frequent changes to signal connections or signal conditioning is required, please refer to the information on the CIO-MINI37 or CIO-TERMINAL screw terminal boards.

For signal conditioning and channel expansion, refer to the information on CIO-EXP32, a 32 channel analog multiplexer/amplifier; CIO-SSH16, a 16 channel simultaneous sample & hold board or the ISO-RACK16 5B module interface rack.

2.2 ANALOG INPUTS

Making reliable, trouble-free analog signal connections can be a challenge when using a data acquisition board. The best method for inputting analog inputs may not be obvious. While a complete coverage of this topic is beyond the scope of this manual, the following section provides simple explanations and helpful hints. When finished, you should have a basic understanding of single-ended versus differential inputs and the concepts of system grounding and isolation.

The CIO-DAS16Jr/16 provides either eight differential or 16 single-ended input channels. Descriptions of single-ended and differential inputs follow.

2.2.1 Single-Ended Inputs

In a single-ended input circuit, the voltage between the input signal terminal and ground is amplified. In this mode, the CIO-DAS16JR/16 amplifies the voltage between the selected input channel CH IN and LLGND. The single-ended input configuration requires only one physical connection (wire) per channel and allows the CIO-DAS16JR/16 to monitor more channels than the (2-wire) differential configuration using the same connector and on-board multiplexer (not shown). However, since the circuit is measuring the input voltage relative to its own low level ground, single-ended inputs are more susceptible to both EMI (Electro Magnetic Interference) and any ground noise at the signal source. Figure 2-2 shows the single-ended input configuration.

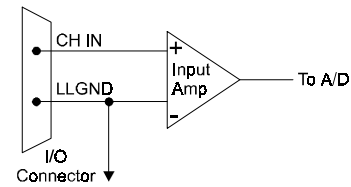

SINGLE-ENDED INPUT

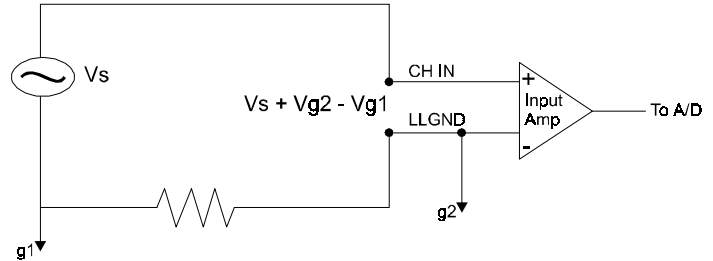

SINGLE-ENDED INPUT WITH COMMON MODE VOLTAGE - Any voltage differential between grounds g1 and g2 shows up as an error signal at the input amplifier.

Figure 2-2. Single-Ended Input Theory

2.2.2 Differential Inputs

In differential input circuits, the voltage between two distinct input signals is amplified. Within a certain range (referred to as the common mode range), the measurement is almost independent of signal source to CIO-DAS16JR/16 ground variations. A differential input is also much more immune to EMI than a single-ended one. Most EMI noise induced in one lead is also induced in the other, the input only measures the difference between the two leads, and the EMI common to both is ignored. This effect is a major reason there is twisted pair wire as the twisting assures that both wires are subject to virtually identical external influence. Figure 2-3 shows a theoretical differential input configuration. Note: Multiplexing is not shown for simplification.

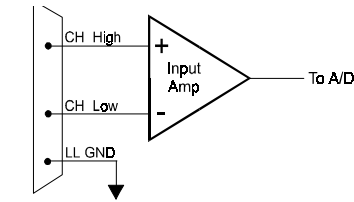

DIFFERENTIAL INPUT

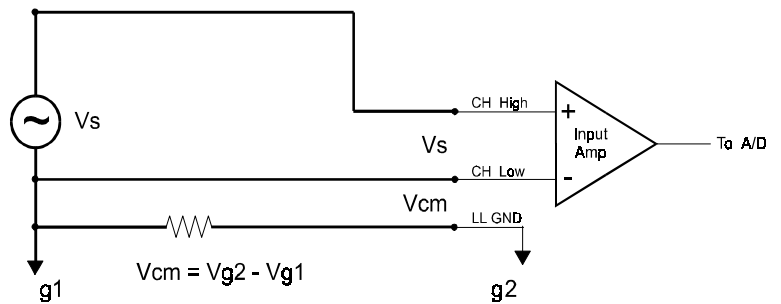

DIFFERENTIAL INPUT - Common Mode Voltage (Vcm) is ignored by differential input configuration. However, note that Vcm + Vs must remain within the amplifier's common mode range of ±10V.

Figure 2-3. Differential Input Theory

Before describing grounding and isolation, it is important to understand the concepts of common mode, and common mode range. Common mode voltage is depicted in the diagram above as V_{cm} . Though differential inputs measure the voltage between two signals, without (almost) respect to the either signal's voltages relative to ground, there is a limit to how far away from ground either signal can go. Though the CIO-DAS16JR/16 has differential inputs, it will not measure the difference between 100V and 101V as 1 Volt (in fact the 100V would destroy the board!). This limitation or common mode range is depicted graphically in the following diagram. The CIO-DAS16JR/16 common mode range is +/- 10 Volts. Even in differential mode, no input signal can be measured if it is more than 10V from the board's low level ground (LLGND).

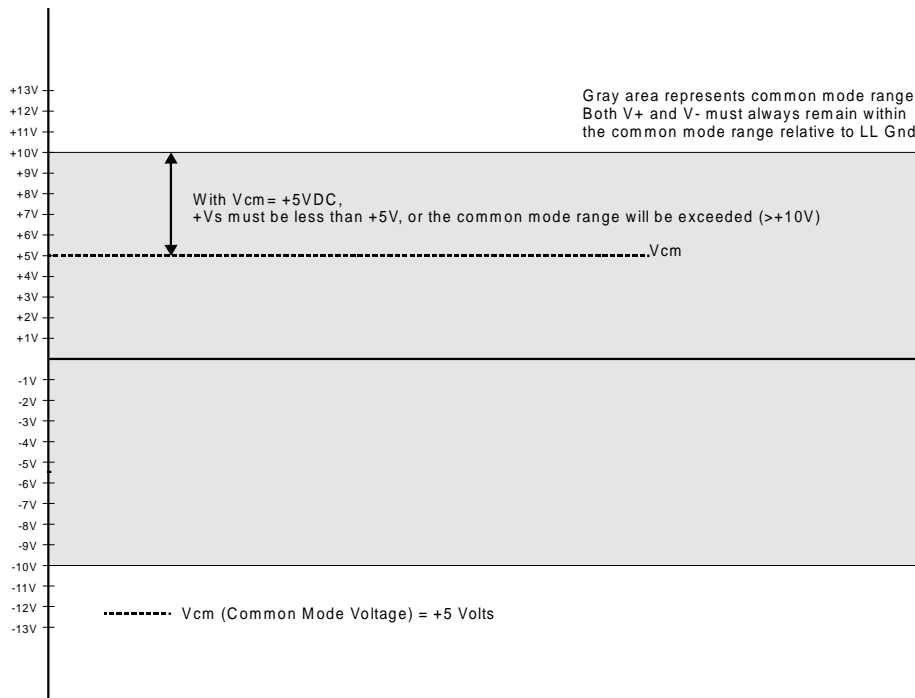

Figure 2-4. Common Mode Range Diagram

2.2.3 System Grounds and Isolation

There are three conditions possible when connecting the signal source to the board.

- 1 The board and the signal source may have the same (or common) ground. This signal source can be connected directly to the board.
- 2 The board and the signal source may have an offset voltage between their grounds (AC and/or DC). This offset is commonly referred to a common mode voltage. Depending on the magnitude of this voltage, it may or may not be possible to connect the board directly to your signal source. We will describe this topic further in a later section.
- 3 The board and the signal source may already have isolated grounds. This signal source can be connected directly to the board.

2.2.4 Determine Your Ground Type

Perform the following test: Using a battery powered voltmeter¹, measure the voltage between the ground signal at your signal source and ground at your PC. Measure both the AC and DC Voltages.

¹ If you do not have a voltmeter, skip the test and read the following three sections. You may be able to identify your system type from the descriptions provided.

If both AC and DC readings are 0.00 volts, you may have a system with common grounds. However, since voltmeters will average out high frequency signals, there is no guarantee. Please refer to the section below entitled Common Grounds.

If you measure a reasonably stable AC and/or DC voltage, your system has an offset voltage between the two grounds. This offset is referred to as a common mode voltage. Please read the following warning and then proceed to the section describing Common Mode systems.

WARNING

If either the AC or DC voltage is greater than 10 volts, do not connect the CIO-DAS16JR/16 to this signal source. You are beyond the boards usable common mode range and will need to either adjust your grounding system or add special Isolation signal conditioning to take useful measurements. A ground offset voltage of more than 30 volts will likely damage the CIO-DAS16JR/16 board and possibly your computer. You must either reconfigure your system to reduce the ground differentials, or purchase and install special electrical isolation signal conditioning.

Note: An offset voltage greater than 30 volts will not only damage your electronics, but may be hazardous to your health.

If you cannot obtain a reasonably stable DC voltage measurement between the grounds, or the voltage drifts around considerably, the two grounds are most likely isolated. The easiest way to check for isolation is to change your voltmeter to it's ohm scale and measure the resistance between the two grounds. *Turn both systems off prior to taking this resistance measurement.* If the measured resistance is more than 100 KOhm, assume your system has electrically isolated grounds.

2.2.5 Systems with Common Grounds

In the simplest (but perhaps least likely) case, your signal source will have the same ground as the CIO-DAS16JR/16. This would typically occur when providing power or excitation to your signal source directly from the CIO-DAS16JR/16. There may be other common ground configurations, but it is important to note that any voltage between the CIO-DAS16JR/16 ground and your signal ground is a potential error voltage if you set up your system based on a common ground assumption.

In general, if your signal source or sensor is not connected directly to an LLGND pin on your CIO-DAS16JR/16, it's best to assume that you do not have a common ground even if your voltmeter measured 0.0 Volts. Configure your system as if there is ground offset voltage between the source and the CIO-DAS16JR/16. This is especially true if you are using either the CIO-DAS1402/16 or the CIO-DAS1402/12 at high gains, since ground potentials in the sub millivolt range will be large enough to cause A/D errors, yet will not likely be measured by your handheld voltmeter.

2.2.6 Systems with Common Mode (ground offset) Voltages

The most frequently encountered grounding problem involves grounds that are somehow connected, but have AC and/or DC offset voltages between the CIO-DAS16JR/16 and signal source grounds. This offset voltage may be AC, DC, or both, and may be caused by a variety of things including EMI pickup, resistive voltage drops in ground wiring and connections, etc. Ground offset voltage is a more appropriate term to describe this type of system, but we'll use the phrase Common Mode.

2.2.7 Small Common Mode Voltages

Even if the voltage between the signal source ground and CIO-DAS16JR/16 ground is small, the combination of the ground voltage and input signal still must not exceed the CIO-DAS800's +/-10V common mode range. (The voltage between grounds, added to the maximum input voltage, must stay within +/-10V.) If this is the case, the system can safely be connected without additional signal conditioning. Fortunately, most systems fall in this category and have a small voltage between grounds.

2.2.8 Large Common Mode Voltages

If the ground differential is large enough, the CIO-DAS800's +/- 10V common mode range will be exceeded. In this case the CIO-DAS16Jr/16 cannot be directly connected to the signal source. You must change your system grounding configuration or add isolation signal conditioning. (Please look at our ISO-RACK and ISO-5B-series products to add electrical isolation, or give our technical support group a call to discuss other options).

NOTE

Do not rely on the earth prong of a 120VAC for signal ground connections. Different ground plugs may have large and potentially even dangerous voltage differentials. Remember that the ground pins on 120VAC outlets on different sides of the room may only be connected in the basement. This leaves the possibility that the "ground" pins may have a significant voltage differential (especially if the two 120 VAC outlets happen to be on different phases!)

2.2.9 CIO-DAS16Jr/16 and Signal Source Have Isolated Grounds

Some signal sources are already electrically isolated from the CIO-DAS16Jr/16. The diagram below shows a typical isolated ground system. These signal sources are often battery powered, or are fairly expensive pieces of equipment (isolation can be expensive). Isolated ground systems provide excellent performance but requires careful design and installation to assure optimum performance. Please refer to the following sections for further details

2.3 WIRING CONFIGURATIONS

Combining all the grounding and input type possibilities provides us with the following connection configurations.

The combinations along with our recommendations on usage are summarized in Table 2-1 below.

Table 2-1. Ground Condition/Input Type Compatibility

GROUND CATEGORY	INPUT CONFIGURATION	OUR VIEW
Common Ground	Single-Ended Inputs	Recommended
Common Ground	Differential Inputs	Acceptable
Common Mode Voltage < +/-10V	Single-Ended Inputs	Not Recommended
Common Mode Voltage < +/-10V	Differential Inputs	Recommended
Common Mode Voltage > +/- 10V	Single-Ended Inputs	Unacceptable without adding Isolation
Common Mode Voltage > +/-10V	Differential Inputs	Unacceptable without adding Isolation
Already Isolated Grounds	Single-ended Inputs	Acceptable
Already Isolated Grounds	Differential Inputs	Recommended

The following sections depicts recommended input wiring schemes for each of the seven possible input configuration/grounding combinations.

NOTE: For simplicity, the input multiplexers are not shown in the following diagrams.

2.3.1 Common Ground / Single-Ended Inputs

Single-ended is the recommended configuration for common ground connections. However, if some of your inputs are common ground and some are not, we recommend you use the differential mode. There is no performance penalty (other than loss of channels) for using a differential input to measure a common ground signal source. However the reverse is not true. Figure 2-5 below shows a basic connection diagram for a common ground / single-ended input system.

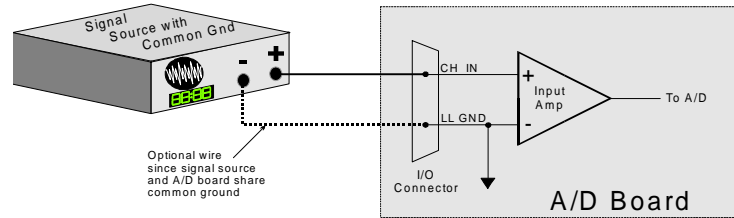

Signal source and A/D board sharing common ground connected to single-ended input.

Figure 2-5. Common Ground / Single-Ended Input

2.3.2 Common Ground / Differential Inputs

The use of differential inputs to monitor a signal source with a common ground is a acceptable configuration though it requires more wiring and offers half the channels of a single-ended configuration. Figure 2-6 below shows the basic connections in this configuration.

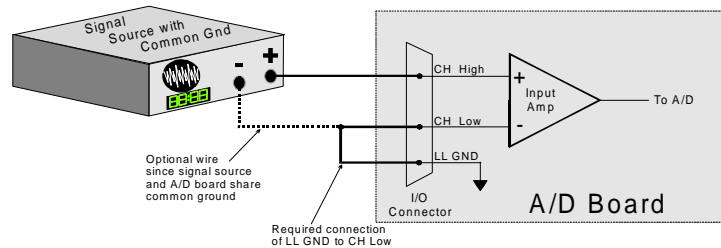

Signal source and A/D board sharing common ground connected to differential input.

Figure 2-6. Common Ground / Differential Inputs

2.3.3 Common Mode Voltage < +/-10V/Single-Ended Inputs

This is not a recommended configuration. In fact, the phrase common mode has no meaning in a single-ended system and this case would be better described as a system with offset grounds. Anyway, you are welcome to try this configuration, no system damage should occur and depending on the overall accuracy you require, you may receive acceptable results.

2.3.4 Common Mode Voltage < +/-10V/Differential Inputs

Systems with varying ground potentials should always be monitored in the differential mode. Care is required to assure that the sum of the input signal and the ground differential (referred to as the common mode voltage) does not exceed the common mode range of the A/D board (+/-10V on the CIO-DAS16JR/16). Figure 2-7 below show recommended connections in this configuration.

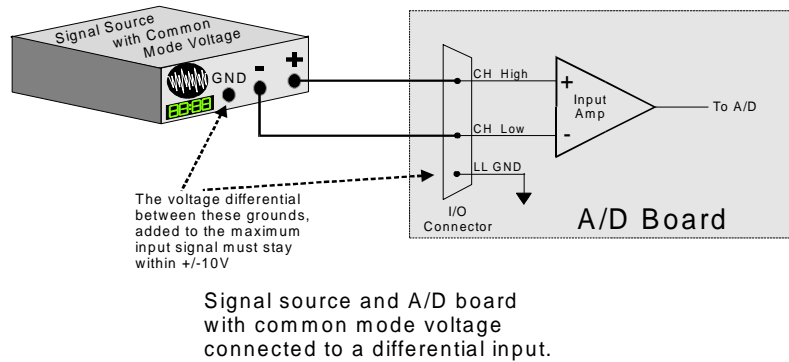

Figure 2-7. Common Mode Voltage < +/-10V/Single-Ended Inputs

2.3.5 Common Mode Voltage > +/-10V

The CIO-DAS16JR/16 will not directly monitor signals with common mode voltages greater than +/-10V. You will either need to alter the system ground configuration to reduce the overall common mode voltage, or add isolated signal conditioning between the source and your board (Figure 2-8).

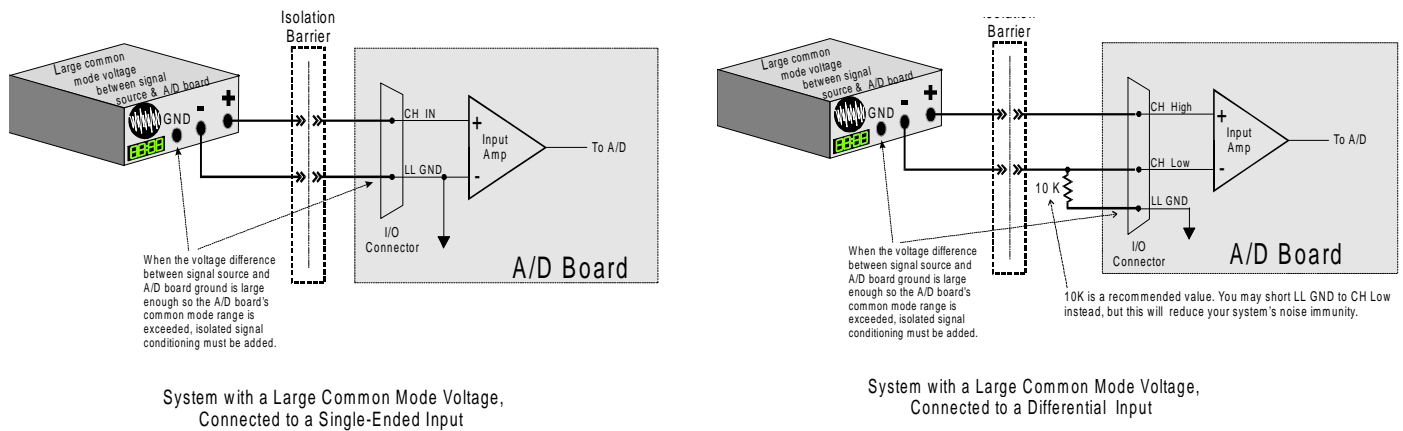
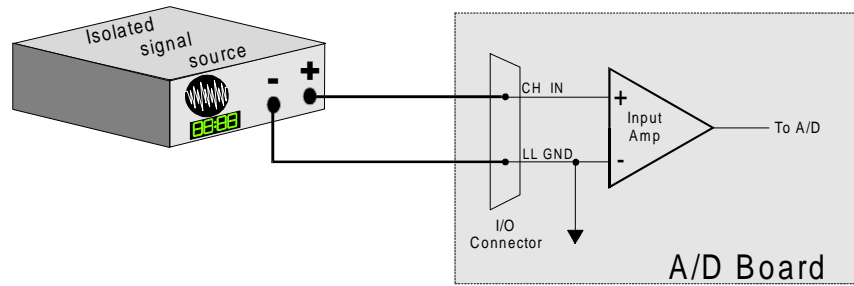

Figure 2-8. Common Mode Voltage > +/-10V - Serial/Differential Inputs

2.3.6 Isolated Grounds / Single-Ended Inputs

Single-ended inputs can be used to monitor isolated inputs, though the use of the differential mode will increase you system's noise immunity. Figure 2-9 below shows the recommended connections in this configuration.



Isolated Signal Source
Connected to a Single-Ended Input

Figure 2-9. Isolated Grounds / Single-Ended Inputs

2.3.7 Isolated Grounds / Differential Inputs

Optimum performance with isolated signal sources is assured with the use of the differential input setting. Figure 2-10 below shows the recommended connections in this configuration..

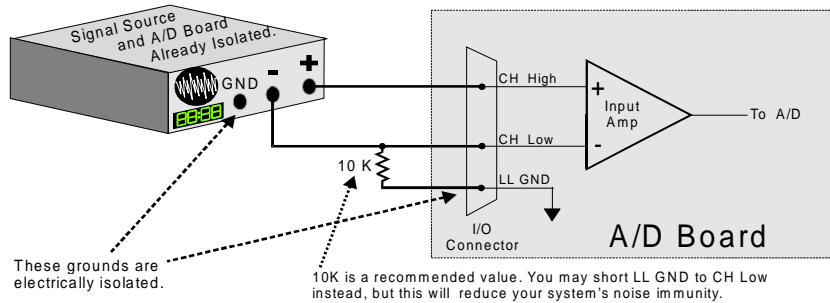

Already isolated signal source
and A/D board connected to
a differential input.

Figure 2-10. Isolated Grounds / Differential Inputs

3 REGISTER ARCHITECTURE

3.1 CONTROL & DATA REGISTERS

The CIO-DAS16Jr/16 is controlled and monitored by writing to and reading from 16 consecutive 8-bit I/O addresses. The first address, or BASE ADDRESS, is determined by setting a bank of switches on the board.

Most often, register manipulation is best left to experienced programmers with a specific need for low level control. If this is the case for you, use the information that follows to write your own code. Otherwise, we strongly suggest you consider using the Universal Library™ instead.

The register descriptions follow all follow the format:

7	6	5	4	3	2	1	0
A/D9	A/D10	A/D11	A/D12	A/D13	A/D14	A/D15	A/D16 LSB

Where the numbers along the top row are the bit positions within the 8-bit byte and the numbers and symbols in the bottom row are the functions associated with that bit.

To write to or read from a register in decimal or hexadecimal, the weights in Table 3-1 apply:

Table 3-1. Bit Weights

BIT POSITION	DECIMAL VALUE	HEX VALUE
0	1	1
1	2	2
2	4	4
3	8	8
4	16	10
5	32	20
6	64	40
7	128	80

To write control or data to a register, the individual bits must be set to 0 or 1 then combined to form a Byte. Data read from registers must be analyzed to determine which bits are on or off.

The method of programming required to set/read bits from bytes is beyond the scope of this manual. It will be covered in most Introduction To Programming books, available from a book store.

In summary form, board registers and their function are listed in Table 3-2. Within each register are eight bits which can constitute a byte of data or can be eight individual bit set/read functions.

Table 3-2. Register Summary

ADDRESS	READ FUNCTION	WRITE FUNCTION
BASE	A/D Bits 9 - 16 (LSB)	Start A/D Function
BASE + 1	A/D Bits 1 (MSB) - 8	None
BASE + 2	Channel MUX Read	Channel MUX Set
BASE + 3	Digital 4 Bit Input	Digital 4 Bit Output
BASE + 4	None	None
BASE + 5	None	None
BASE + 6	None	None
BASE + 7	None	None
BASE + 8	Status EOC, UNI/BIP etc.	None
BASE + 9	DMA, Interrupt & Trigger Control	Set DMA, INT etc
BASE + 10	Pacer clock control register.	None
BASE + 11	Gain setting read-back	Gain control
BASE + 12	Counter 0 Data	Counter 0 Data
BASE + 13	CTR 1 Data - A/D Pacer Clock	CTR 1 Data - A/D Pacer
BASE + 14	CTR 2 Data - A/D Pacer Clock	CTR 2 Data - A/D Pacer
BASE + 15	None. No read back on 8254	Pacer Clock Control (8254)

3.2 A/D DATA & CHANNEL REGISTERS

BASE ADDRESS

7	6	5	4	3	2	1	0
A/D9	A/D10	A/D11	A/D12	A/D13	A/D14	A/D15	A/D16 LSB

A read/write register.

READ

On read, it contains the 8LSB's of A/D data.

WRITE

Writing any data to the register causes an immediate A/D conversion.

BASE ADDRESS + 1

7	6	5	4	3	2	1	0
A/D1 MSB	A/D2	A/D3	A/D4	A/D5	A/D6	A/D7	A/D8

A Read-only register.

On read the most significant A/D byte is read.

3.3 CHANNEL MUX SCAN LIMITS REGISTER

BASE ADDRESS + 2

7	6	5	4	3	2	1	0
CH H8	CH H4	CH H2	CH H1	CH L8	CH L4	CH L2	CH L1

A read and write register.

READ

The current channel scan limits are read as one byte. The high channel number scan limit is in the most significant 4 bits. The low channel scan limit is in the least significant 4 bits.

WRITE

The channel scan limits desired are written as one byte. The high channel number scan limit is in the most significant 4 bits. The low channel scan limit is in the least significant 4 bits.

Bits 3-0 contain the starting channel number and bits 7-4 contain the ending channel number. If you wanted to scan channels 1, 2, 3 in that order, you could do so by placing the 3 in bits 7-4 and the 1 in bits 3-0.

NOTE

Every write to this register sets the current A/D channel MUX setting to the number in bits 3-0. See BASE + 8.

3.4 4-BIT DIGITAL I/O REGISTERS

BASE ADDRESS + 3

7	6	5	4	3	2	1	0
0	0	0	0	DI3	DI2, CTR0 GATE	DI1	DI0, TRIG

When read...

READ

The signals present at the inputs are read as one byte, the most significant four bits of which are always zero. Note that pins 25 (digital input 0) and 24 (digital input 2) have two functions each.

The TRIG function of digital input 0 may be used to hold off the first sample of an A/D set by holding it low (0V) until you are ready to take samples, which are then paced by the 8254. It can also be used as the source of an external start conversion pulse, synchronizing A/D conversions to some external event.

When written to..

WRITE

The upper four bits are ignored. The lower four bits are latched TTL outputs. Once written, the state of the inputs cannot be read back because a read back would read the separate digital input lines (see above).

3.5 STATUS REGISTER

BASE ADDRESS + 8

7	6	5	4	3	2	1	0
EOC	U/B	MUX	INT	CH8	CH4	CH2	CH1

A read mostly, one-function-write register.

READ

EOC = 1, the A/D converter is busy. EOC = 0, it is free.

U/B = 1, the amplifier is in Unipolar mode. U/B = 0, is bipolar.

MUX = 1, Channels are configured 16 single ended. MUX = 0, 8 differential.

INT = 1, an external pulse has been received. INT = 0, the flip-flop is ready to receive a pulse..

There is a flip-flop on the TRIGGER input (pin 25) which will latch a pulse as short as 200 nanoseconds. Once triggered, this flip-flop must be reset by a write to this register. Your interrupts service routine must do this before another interrupt trigger can be received.

CH8, CH4, CH2 & CH1 are a binary number between 0 and 15 indicating the channel number that the MUX is currently set to and is valid only when EOC = 0. The channel MUX increments shortly after EOC = 1 so may be in a state of transition when EOC = 1. The binary weight of each bit is shown in Table 3-1 above.

WRITE

A write of any data to this register resets the flip-flop on the pin 25 input and sets the INT bit to 0.

3.6 DMA, INTERRUPT & TRIGGER CONTROL

BASE ADDRESS + 9

7	6	5	4	3	2	1	0
INTE	IR4	IR2	IR1	Don't Care	DMA	TS1	TS0

A read and write register.

READ

INTE = 1, Interrupts are enabled. An interrupt generated will be placed on the PC bus interrupt level selected by IR4, IR2 & IR1. INTE = 0, interrupts are disabled.

IR4, IR2, IR1 are bits in a binary number between 0 and 7 which map interrupts onto the PC bus interrupt levels 2 - 7. Interrupts 0 & 1 may not be asserted by the CIO-DAS16Jr/16.

DMA = 1, DMA transfers are enabled. DMA = 0, DMA transfers are disabled. Note that this bit only allows the board to assert a DMA request to the PC on the DMA request level selected by the DMA switch. Before this bit is set to 1, the PC's 8237 (or appropriate) DMA controller chip must be set up.

TS1 & TS0 control the source of the A/D start conversion trigger according to Table 3-3 below.

Table 3-3. A/D Conversion Source Coding

TS1	TS0	
0	X	Software triggered A/D only
1	0	Start on rising TRIGGER (Digital input 0, Pin 25)
1	1	Start on Pacer Clock Pulse (CTR 2 OUT, no external access)

3.7 PACER CLOCK CONTROL REGISTER

BASE ADDRESS + 10

7	6	5	4	3	2	1	0
X	X	X	X	X	X	CTR0	TRIG0

Write only

CTR0 = 1. When CTR0 = 1, an on-board 100 kHz lock signal is ANDed with the COUNTER 0 CLOCK INPUT (pin 21). A high on pin 21 will allow pulses from the on-board source into the 82C54 Counter 0 input.

CTR0 = 0. When CTR0 = 0, the input to 82C54 Counter 0 is entirely dependent on pulses at pin 21, COUNTER 0 CLOCK INPUT.

TRIG0 = 1. When TRIG0 = 1, the TRIGGER input at pin 25 is ANDed with TRIG0 which must therefore be high for the pulses from the on-board pacer clock (82C54) to start A/D conversions. The input at pin 25 is pulled up and will always be high unless pulled low externally.

TRIG0 = 0. When TRIG0 = 0, the GATES of counter 1 & 2 are held high, preventing gating of the pacer clock from pin 25. Reviewing Figure 3-1 may help in understanding the functions of these registers.

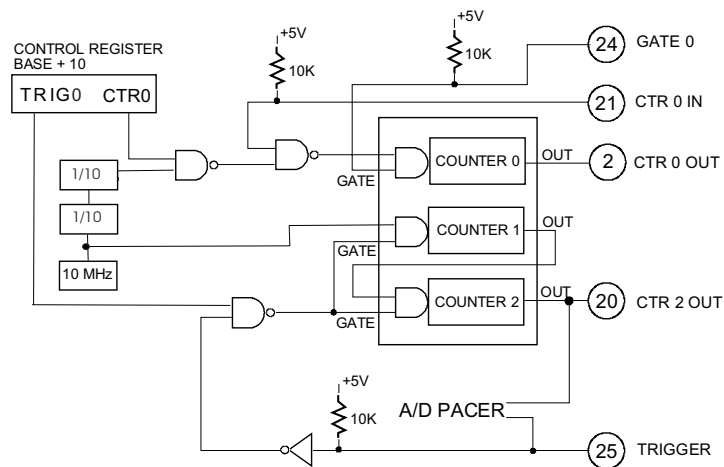

CIO-DAS16 8254 PACER CLOCK & CONTROL

Figure 3-1. Pacer Control Logic

3.8 ANALOG INPUT RANGE REGISTER

BASE ADDRESS + 11

7	6	5	4	3	2	1	0
X	X	X	X	X	Uni/Bip	G1	G0

Table 3-4. Range Coding

UNI/BIP	G1	G0	INPUT RANGE	DECIMAL
0	0	0	±10V	0
0	0	1	±5V	1
0	1	0	±2.5V	2
0	1	1	±1.25V	3
1	0	0	0 to 10V	4
1	0	1	0 to 5V	5
1	1	0	0 to 2.5V	6
1	1	1	0 to 1.25V	7

READ or WRITE

A write to this register sets the analog input range for all 8/16 analog inputs. The lower three bits set the analog input range (Table 3-4). The upper five bits are not used.

To set the analog input range of the CIO-DAS16Jr/16 programmatically, write the correct input range code to the base address + 11. For example, from BASIC:

If the board's base address is 300h (768 decimal), then the gain register is at $768 + 11 = 779$

OUT 779, 5 'Set analog output range to 0 to 5V

The decimal range codes are in the far right column above.

3.9 PACER CLOCK DATA & CONTROL REGISTERS

8254 COUNTER 0 DATA

BASE ADDRESS + 12

7	6	5	4	3	2	1	0
D8	D7	D6	D5	D4	D3	D2	D1

8254 COUNTER 1 DATA

BASE ADDRESS + 13

7	6	5	4	3	2	1	0
D8	D7	D6	D5	D4	D3	D2	D1

8254 COUNTER 2 DATA

BASE ADDRESS + 14

7	6	5	4	3	2	1	0
D8	D7	D6	D5	D4	D3	D2	D1

The three 8254 counter/timer data registers may be written to and read from. Because each counter will count as high as 65,535, it is clear that loading or reading the counter data must be a multi-step process. Refer to the 8254 data sheet at <http://www.measurementcomputing.com/PDFmanuals/82C54.pdf> for details regarding the programming of the 8254 counter / timer.

82C54 COUNTER CONTROL

BASE ADDRESS + 15

7	6	5	4	3	2	1	0
D8	D7	D6	D5	D4	D3	D2	D1

WRITE ONLY

This register controls the operation and loading/reading of the counters. Refer to the 8254 data sheet at <http://www.measurementcomputing.com/PDFmanuals/82C54.pdf> for details regarding the programming of the 8254 counter / timer.

3.10 ANALOG INPUT

Analog signals connected to P1, the 37D connector which protrudes from the expansion slot of the PC, are first fed into the two HI-0508 analog multiplexers. A multiplexer's (MUX) function is to select one of several (8) inputs and connect that input to the MUX output. MUX U5 connects CH0-CH7 high inputs. MUX U9 connects CH0-CH7 Low input (differential input mode) or CH8-CH15 High inputs (single-ended mode) depending on the state of the channel configuration switch located at the upper right of the board and marked 8/16.

From the output of the MUX, the analog signal is fed into a programmable differential amplifier.

The A/D converter chip has an integral sample & hold circuit, greatly simplifying design and improving signal integrity. The A/D converter is capable of sampling rates to 100 kHz but the DMA transfer circuitry of the personal computer's 8-bit bus may limit the transfer rate to less than the maximum A/D rate. Therefore, the maximum sampling rate of the CIO-DAS16Jr/16 is dependent on the computer.

3.11 DIGITAL INPUT & OUTPUT

There are four bits of output-only and four bits of input-only on the CIO-DAS16Jr/16 analog connector. From the original DAS-16 design, these were the only eight bits of digital I/O.

3.12 OUTPUT

The output bits are part of chip U20, a 74LS197 output buffer. The other half of the chip is used for on-board control. If the digital output lines are blown by overload or high voltage connection, you can replace this chip.

3.13 INPUT

The input bits are part of chip U23, a 74LS244 buffer. The other half of this chip is used for on board functions. This chip is socketed.

4 SPECIFICATIONS

POWER CONSUMPTION

+5V quiescent 850 mA typical, 1250 mA max

ANALOG INPUT SECTION

A/D converter type	AD7805PB
Resolution	16 bits
Number of channels	8 differential or 16 single-ended (switch-selectable)
Input ranges	$\pm 10V$, $\pm 5V$, $\pm 2.5V$, $\pm 1.25V$, 0 to 10V, 0 to 5V, 0 to 2.5V, 0 to 1.25V, fully programmable
Polarity	Unipolar/Bipolar programmable, 11 ms max switching delay
A/D pacing	Programmable: internal counter or external source (DIG. IN 0 / TRIGGER, rising edge) or software polled
A/D Trigger sources	External polled gate trigger (DIG. IN 0 / TRIGGER, active high)
A/D Triggering Modes	
Digital:	Gated pacer, software polled. (Gate must be disabled by software after trigger event.)
Data transfer	DMA, interrupt or software polled
DMA	Channels 1 and 3, switch-selectable
DMA enable	Programmable
A/D conversion time	10 μ s
Throughput	100 kHz typical, PC dependent
Absolute accuracy	0.0023% of reading ± 1.5 LSB
Differential Linearity error	$+1.5/-1$ LSB
Integral Linearity error	± 1.5 LSB
No missing codes (guaranteed)	16 Bits
Gain drift (A/D specs)	± 10 ppm/ $^{\circ}$ C
Zero drift (A/D specs)	± 5 ppm/ $^{\circ}$ C
Common Mode Range	$\pm 10V$
CMRR @ 60 Hz	-96 dB
Input leakage current (@ 25 deg C)	200 nA
Input impedance	30 Meg Ω
Absolute maximum input voltage	$\pm 35V$

DIGITAL I/O SECTION

Digital type	
Output	74LS197
Input	74LS244
Configuration	4 fixed input, 4 fixed output
Number of channels	8
Output High	2.7 volts min @ -0.4 mA
Output Low	0.5 volts max @ 8 mA
Input High	2.0 volts min, 7 volts absolute max
Input Low	0.8 volts max, -0.5 volts absolute min
Interrupts	Programmable: levels 2 thru 7
Interrupt enable	Programmable
Interrupt sources	A/D End-of-conversion, DMA terminal count

COUNTER SECTION

Counter type 82C54
Configuration 3 down counters, 16 bits each

Counter 0 - independent, available to user
Source: programmable: external (CTR0 Clock In) or 100 kHz internal
Gate: programmable: external (Dig In 2 / Ctr 0 Gate, active high) or disabled
Output: Available at user connector (CTR 0 Out)

Counter 1 - ADC Pacer Lower Divider
Source: 10 MHz internal
Gate: Tied to Counter 2 gate, programmable source: internal or external (DIG. IN 0 / TRIGGER).
Output: Chained to Counter 2 Clock.

Counter 2 - ADC Pacer Upper Divider
Source: Counter 1 Output.
Gate: Tied to Counter 1 gate, programmable source: internal or external (DIG. IN 0 / TRIGGER).
Output: ADC Pacer clock, available at user connector (CTR 2 Out)

Clock input frequency	10 Mhz max
High pulse width (clock input)	30 ns min
Low pulse width (clock input)	50 ns min
Gate width high	50 ns min
Gate width low	50 ns min
Input low voltage	0.8V max
Input high voltage	2.0V min
Output low voltage	0.4V max
Output high voltage	3.0V min

Crystal oscillator	Frequency	10 MHz
	Frequency accuracy	100 ppm

ENVIRONMENTAL

Operating temperature range	0 to 50°C
Storage temperature range	-20 to 70°C
Humidity	0 to 90% non-condensing

For your notes.

EC Declaration of Conformity

We, Measurement Computing Corp., declare under sole responsibility that the product:

CIO-DAS16Jr/16

Part Number	Description
-------------	-------------

to which this declaration relates, meets the essential requirements, is in conformity with, and CE marking has been applied according to the relevant EC Directives listed below using the relevant section of the following EC standards and other normative documents:

EU EMC Directive 89/336/EEC: Essential requirements relating to electromagnetic compatibility.

EU 55022 Class B: Limits and methods of measurements of radio interference characteristics of information technology equipment.

EN 50082-1: EC generic immunity requirements.

IEC 801-2: Electrostatic discharge requirements for industrial process measurement and control equipment.

IEC 801-3: Radiated electromagnetic field requirements for industrial process measurements and control equipment.

IEC 801-4: Electrically fast transients for industrial process measurement and control equipment.

Carl Haapaoja, Director of Quality Assurance

Measurement Computing Corporation
16 Commerce Boulevard,
Middleboro, Massachusetts 02346
(508) 946-5100
Fax: (508) 946-9500
E-mail: info@measurementcomputing.com
www.measurementcomputing.com