

BNC-08DI
BNC-16DI
BNC-16SE



Revision 1A
November 1998

Trademark and Copyright Information

Measurement Computing Corporation, InstaCal, Universal Library, and the Measurement Computing logo are either trademarks or registered trademarks of Measurement Computing Corporation. Refer to the Copyrights & Trademarks section on mccdaq.com/legal for more information about Measurement Computing trademarks. Other product and company names mentioned herein are trademarks or trade names of their respective companies.

© 1998 Measurement Computing Corporation. All rights reserved. No part of this publication may be reproduced, stored in a retrieval system, or transmitted, in any form by any means, electronic, mechanical, by photocopying, recording, or otherwise without the prior written permission of Measurement Computing Corporation.

Notice

Measurement Computing Corporation does not authorize any Measurement Computing Corporation product for use in life support systems and/or devices without prior written consent from Measurement Computing Corporation. Life support devices/systems are devices or systems that, a) are intended for surgical implantation into the body, or b) support or sustain life and whose failure to perform can be reasonably expected to result in injury. Measurement Computing Corporation products are not designed with the components required, and are not subject to the testing required to ensure a level of reliability suitable for the treatment and diagnosis of people.

TABLE OF CONTENTS

INTRODUCTION	1
BNC-08DI	2
B1-B16	2
P2	2
P1	2
EXTERNAL TRIGGER	3
BNC-16DI	4
B1-B16	4
P2	4
P3	4
P4 & P5	4
P1	5
EXTERNAL TRIGGER	6
P6 & P7	6
BNC-16SE	8
B1-B16	8
P2	8
P3	8
P4 & P5	8
P1	9
EXTERNAL TRIGGER	10
P6 & P7	10
P1 CONNECTOR MAP	12
BOARD COMPATIBILITY	14
INPUT CONFIGURATIONS	15
BOARD ACCESSIBILITY	19

INTRODUCTION

The BNC series of signal connection boxes have been designed as universal interfaces for the DAS family of analog I/O boards. The BNC-08DI accepts up to 8 differential pairs of analog inputs while the BNC-16SE and the BNC-16DI can accept up to 64 single ended or 32 differential analog inputs. For user convenience, a variety of I/O signals from the DAS board are brought out to a 37 pin D connector at the front of the enclosure.



The BNC-08DI incorporates 16 front panel mounted BNC connectors providing up to 8 differential analog inputs to the CIO-DAS family of data acquisition boards.

B1-B16

The 16 front panel mounted BNC connectors B1-B16, are routed through the enclosure to the rear panel-mounted 37 D connector P2.

P2

The rear panel mounted 37 pin D connector P2, provides the analog output signals from the BNC connectors to the data acquisition board, with the physical connection between P2 and the data acquisition board being made through a 37 pin cable such as the C-37FF-X.

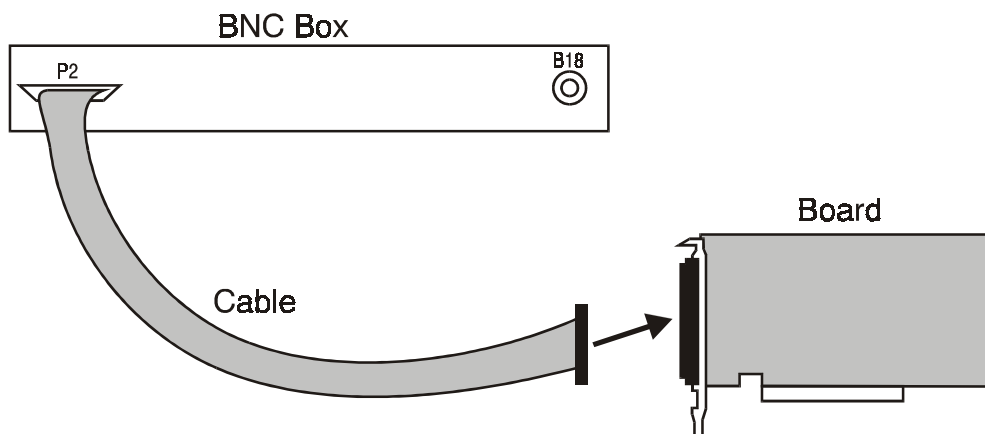

P1

The front panel mounted DB37 connector P1 provides a variety of I/O signals, not including the 16 analog input signals from BNC's B1-B16. Please refer to the P1 CONNECTOR MAP section for a detailed explanation of P1's connection scheme and signal availability.

EXTERNAL TRIGGER

The EXTERNAL TRIGGER BNC connectors B17 and B18 are provided for applications that require external digital triggering of the data acquisition board. These connectors could also be used in applications requiring synchronization to the digital trigger signal.

The digital trigger signal is available on connectors P1-P4 as illustrated in the following diagram.

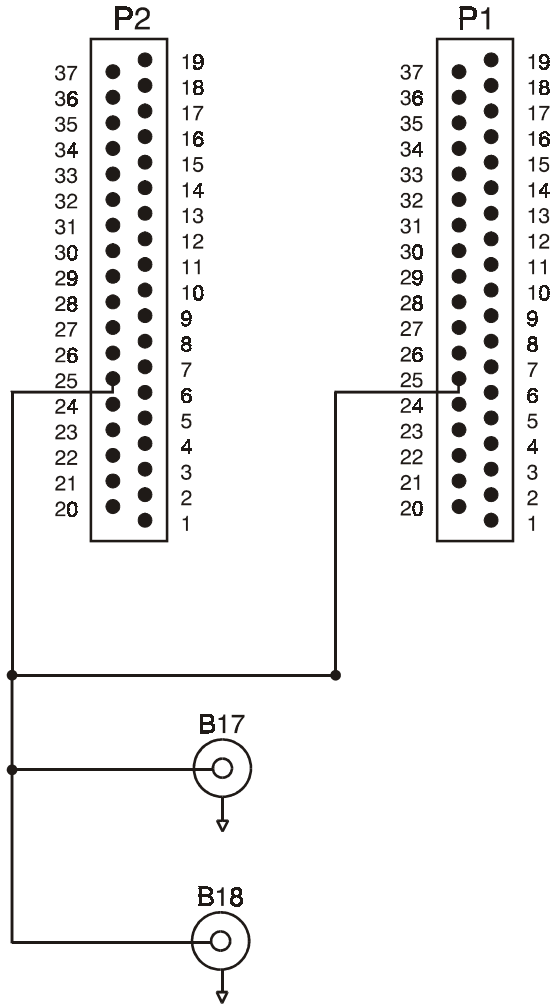

The BNC-16DI incorporates 16 front panel mounted BNC's allowing connection of up to 8 differential analog inputs to the CIO-DAS and PCI family of data acquisition boards. The BNC-16DI can accommodate boards with either 37 or 50 pin I/O connectors; with connector P2 used to interface to data acquisition boards utilizing a 37 pin, D type I/O connector, while connectors P3, P4 and P5 are used to interface to data acquisition boards utilizing a 100 pin I/O connector.

B1-B16

The 16 front panel mounted BNC connectors B1-16, are routed through the enclosure to the rear panel-mounted connectors P2, P3, and P4.

P2

Connector P2 "IN" is a 37 pin D connector which provides the connection between the 16 analog input BNC's to data acquisition boards utilizing a 37 pin, D type I/O connector.

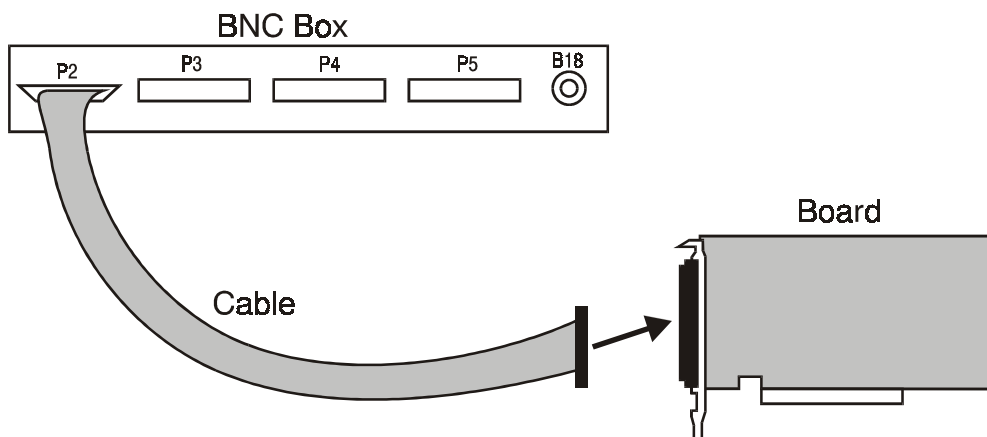

P3

Connector P3 "IN" is a 50 pin connector which provides the connection between the 16 analog input BNC's to data acquisition boards utilizing a 100 pin I/O connector.

P4 & P5

Connector P4 "IN" is a 50 pin connector which provides the connection of the **first 8 differential analog input channels** to a 32 channel differential data acquisition board. When P4 is used in conjunction with 50 pin connector P5 "OUT", the user can daisy chain multiple BNC-16DI boxes, allowing connection of up to 32 differential analog input channels to a single 32 channel differential DAS board (see the diagram on the next page for daisy chain connection scheme).

BNC-16DI 16 Channels

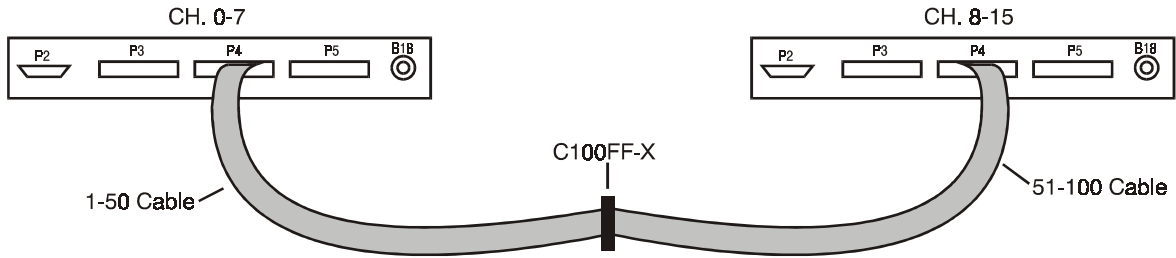

BNC-16DI 24 Channels

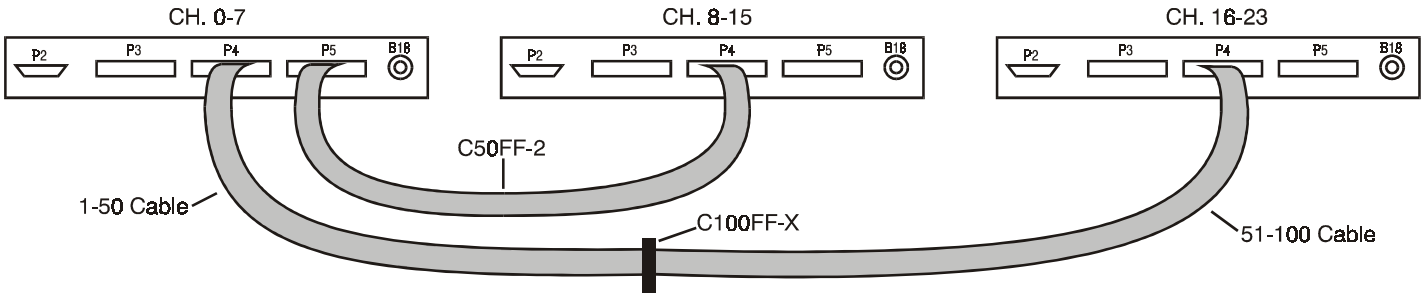

BNC-16DI 32 Channels

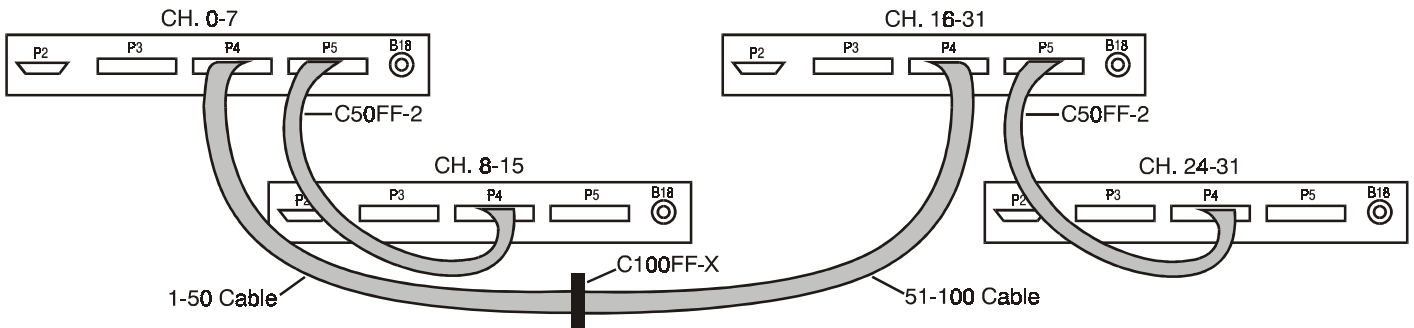

P1

The front panel mounted DB37 connector P1 provides a variety of I/O signals, not including the 16 analog input signals from BNC's B1-B16. Please refer to the P1 CONNECTOR MAP section for a detailed explanation of P1's connection scheme and signal availability.

EXTERNAL TRIGGER

The EXTERNAL TRIGGER BNC connectors B17 and B18 are provided for applications that require external digital triggering of the data acquisition board. These connectors could also be used in applications requiring synchronization to the digital trigger signal.

The digital trigger signal is available on connectors P1-P4 as illustrated in the following diagram.

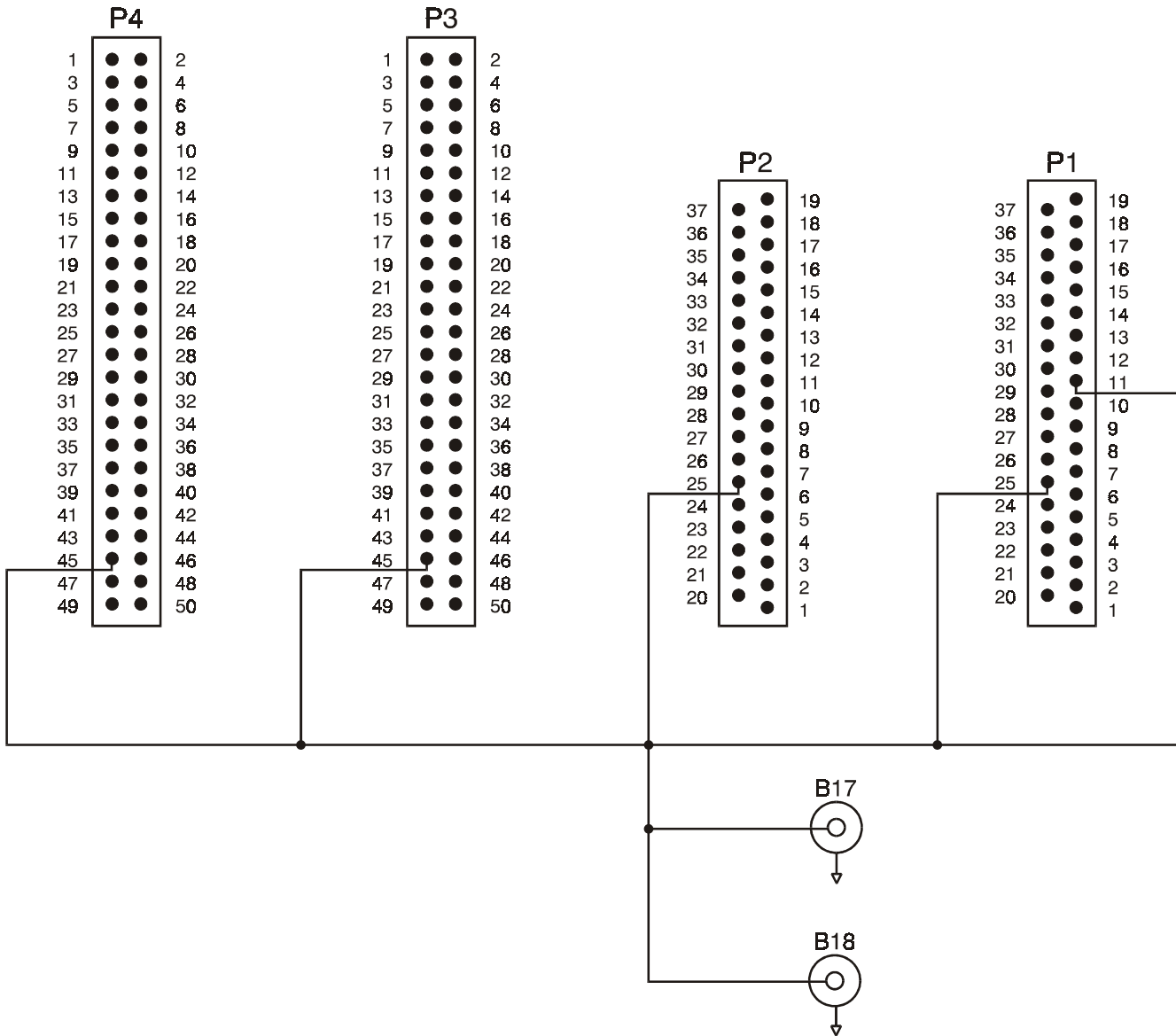

P6 & P7

The internal PC board of the BNC enclosures (BNC16DI/SE only) contain 3 pin headers P6 and P7 which allows the user to modify the function of BNC's B15 and B16 from analog inputs to D/A outputs. Users should consult their DAS manual's I/O connector pin assignment section to verify that the data acquisition board being used has D/A output capability.

P6 & P7 Position	B15 & B16
1-2	Analog Input Mode
2-3	D/A Output Mode

Headers P6 and P7 are factory set to the “1-2” position, pre-configuring B15 and B16 as analog input BNC’s. For those applications which require D/A outputs along with B15 and B16 to be used in the analog input mode; the user can leave B15 and B16 in the analog input mode and access the D/A outputs at connector P1.

The following diagram illustrates the connection scheme used to route the D/A output signals from P2-P4 to B15, B16 and P1.

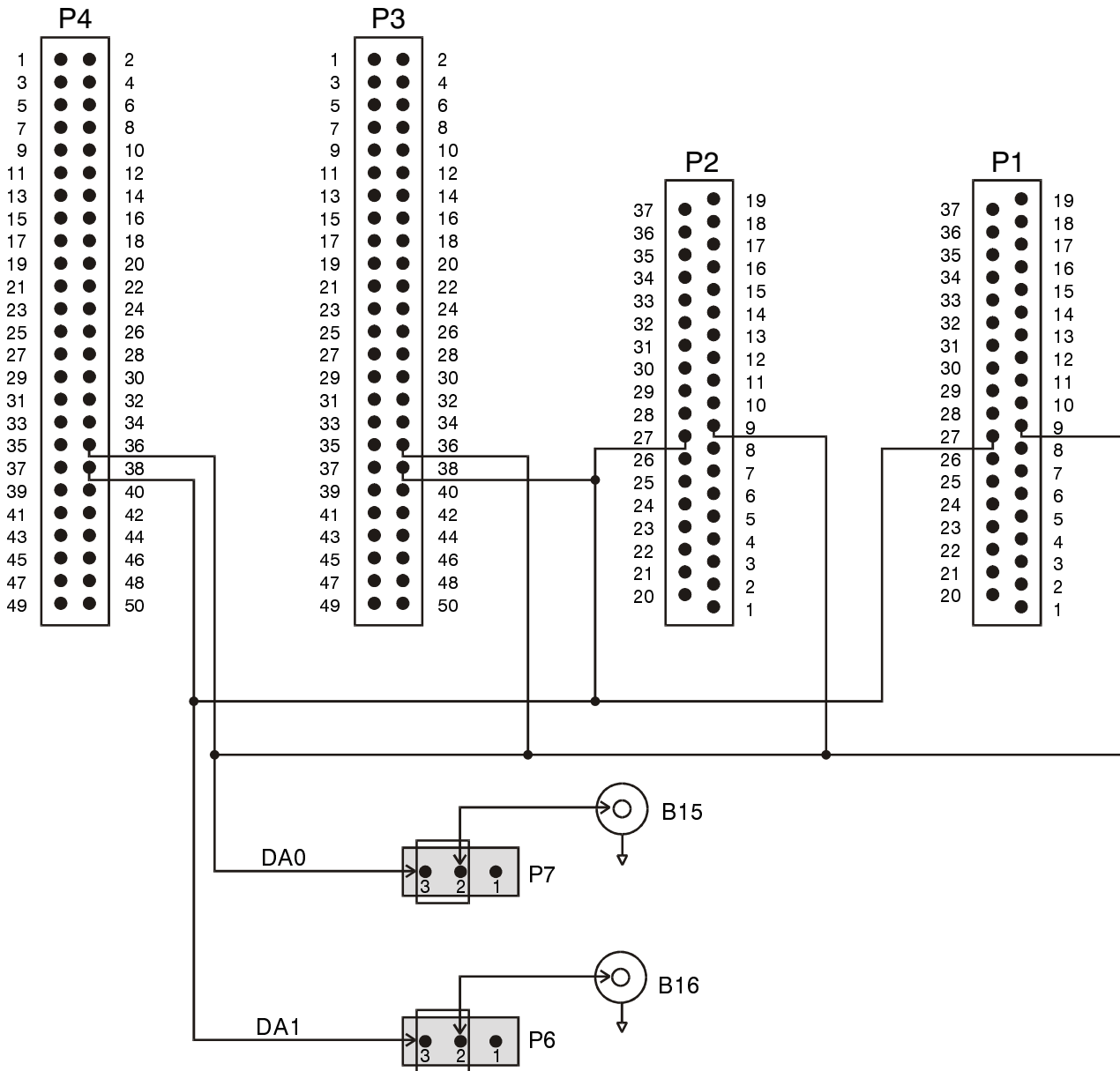

The BNC-16SE incorporates 16 front panel mounted BNC's allowing connection of up to 16 single-ended analog inputs to the CIO-DAS and PCI family of data acquisition boards. The BNC-16SE can accommodate boards with either 37 or 50 pin I/O connectors; with connector P2 used to interface to data acquisition boards utilizing a 37 pin D type I/O connector, while connectors P3, P4 and P5 are used to interface to data acquisition boards utilizing a 100 pin I/O connector.

B1-B16

The 16 front panel mounted BNC connectors B1-16, are routed through the enclosure to the rear panel-mounted connectors P2, P3, and P4.

P2

Connector P2 "IN" is a 37 pin D connector which provides the connection between the 16 analog input BNC's to data acquisition boards utilizing a 37 pin, D type I/O connector.

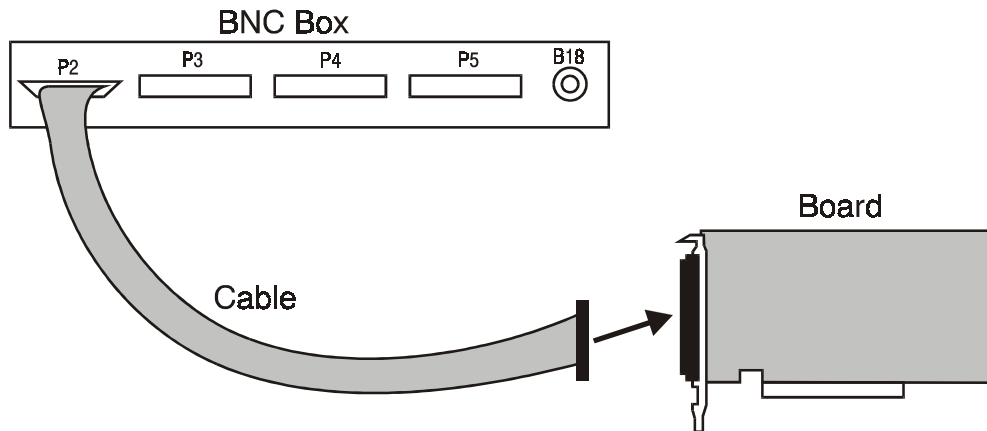

P3

Connector P3 "IN" is a 50 pin connector which provides the connection between the 16 analog input BNC's to data acquisition boards utilizing a 100 pin I/O connector.

P4 & P5

Connector P4 "IN" is a 50 pin connector which provides the connection of the **first 16 single-ended analog input channels** to a 64 channel single-ended data acquisition board. When P4 is used in conjunction with 50 pin connector P5 "OUT", the user can daisy chain multiple BNC-16SE boxes, allowing connection of up to 64 single-ended analog input channels to a single 64 channel single-ended DAS board (see diagram on next page for daisy chain connection scheme).

BNC-16SE 32 Channels

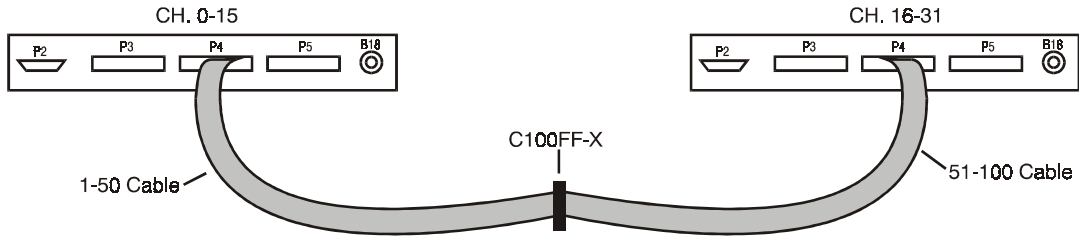

BNC-16SE 48 Channels

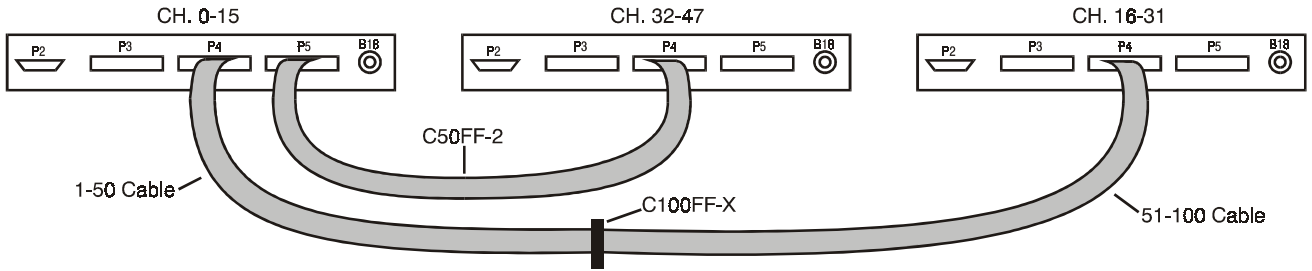

BNC-16SE 64 Channels

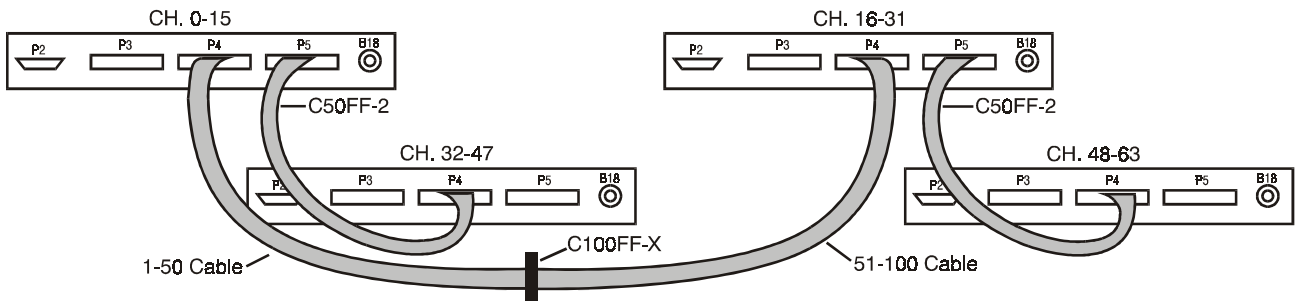

P1

The front panel mounted DB37 connector P1 provides a variety of I/O signals, not including the 16 analog input signals from BNC's B1-B16. Please refer to the P1 CONNECTOR MAP section for a detailed explanation of P1's connection scheme and signal availability.

EXTERNAL TRIGGER

The EXTERNAL TRIGGER BNC connectors B17 and B18 are provided for applications that require external digital triggering of the data acquisition board. These connectors could also be used in applications requiring synchronization to the digital trigger signal.

The digital trigger signal is available on connectors P1-P4 as illustrated in the following diagram.

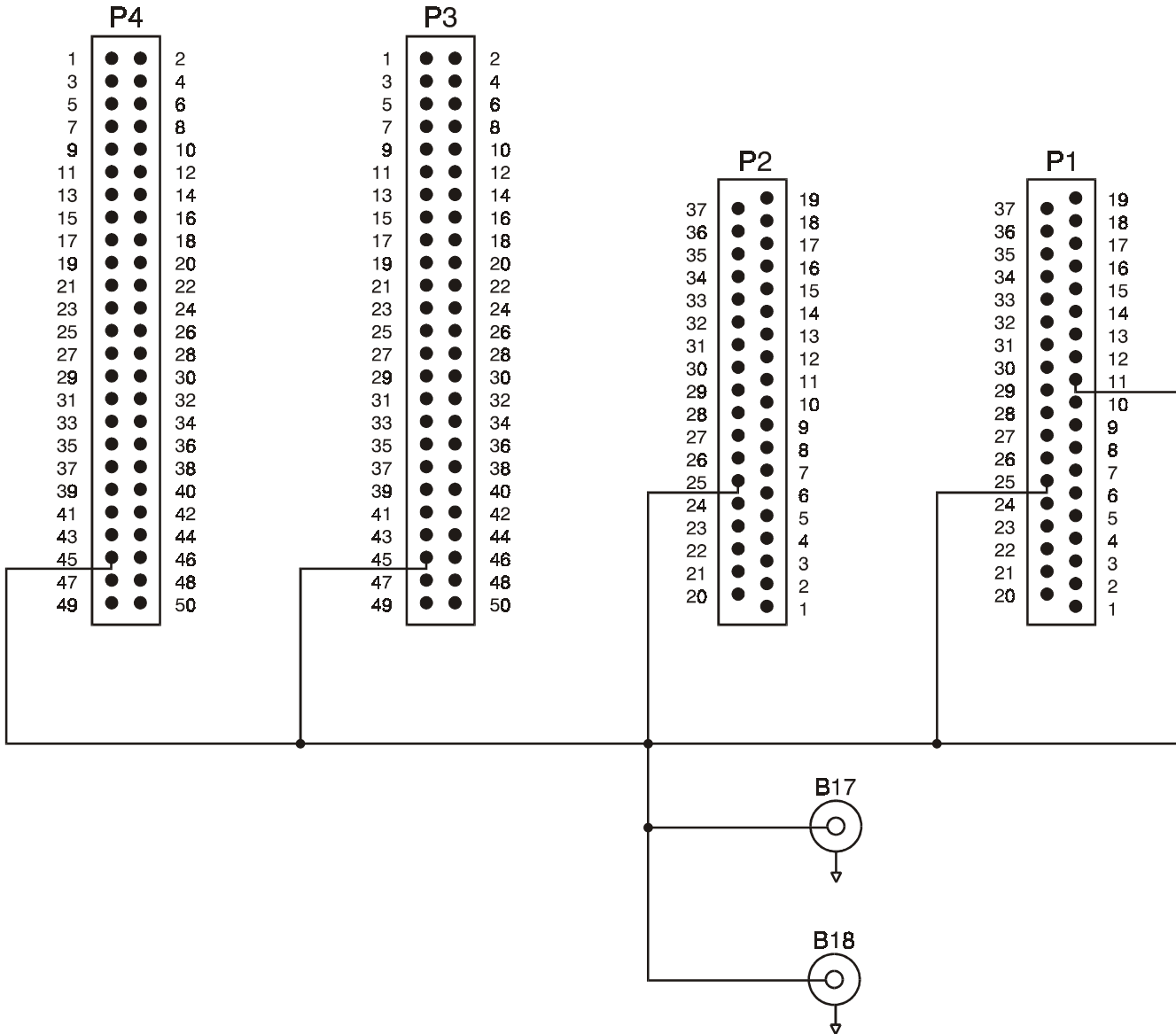

P6 & P7

The internal PC board of the BNC enclosures (BNC16DI/SE only) contain 3 pin headers P6 and P7 which allows the user to modify the function of BNC's B15 and B16 from analog inputs to D/A outputs. Users should consult their DAS manual's I/O connector pin assignment section to verify that the data acquisition board being used has D/A output capability.

P6 & P7 Position	B15 & B16
1-2	Analog Input Mode
2-3	D/A Output Mode

Headers P6 and P7 are factory set to the “1-2” position, pre-configuring B15 and B16 as analog input BNC’s. For those applications which require D/A outputs along with B15 and B16 to be used in the analog input mode; the user can leave B15 and B16 in the analog input mode and access the D/A outputs at connector P1.

The following diagram illustrates the connection scheme used to route the D/A output signals to from P2-P4 to B15, B16 and P1.

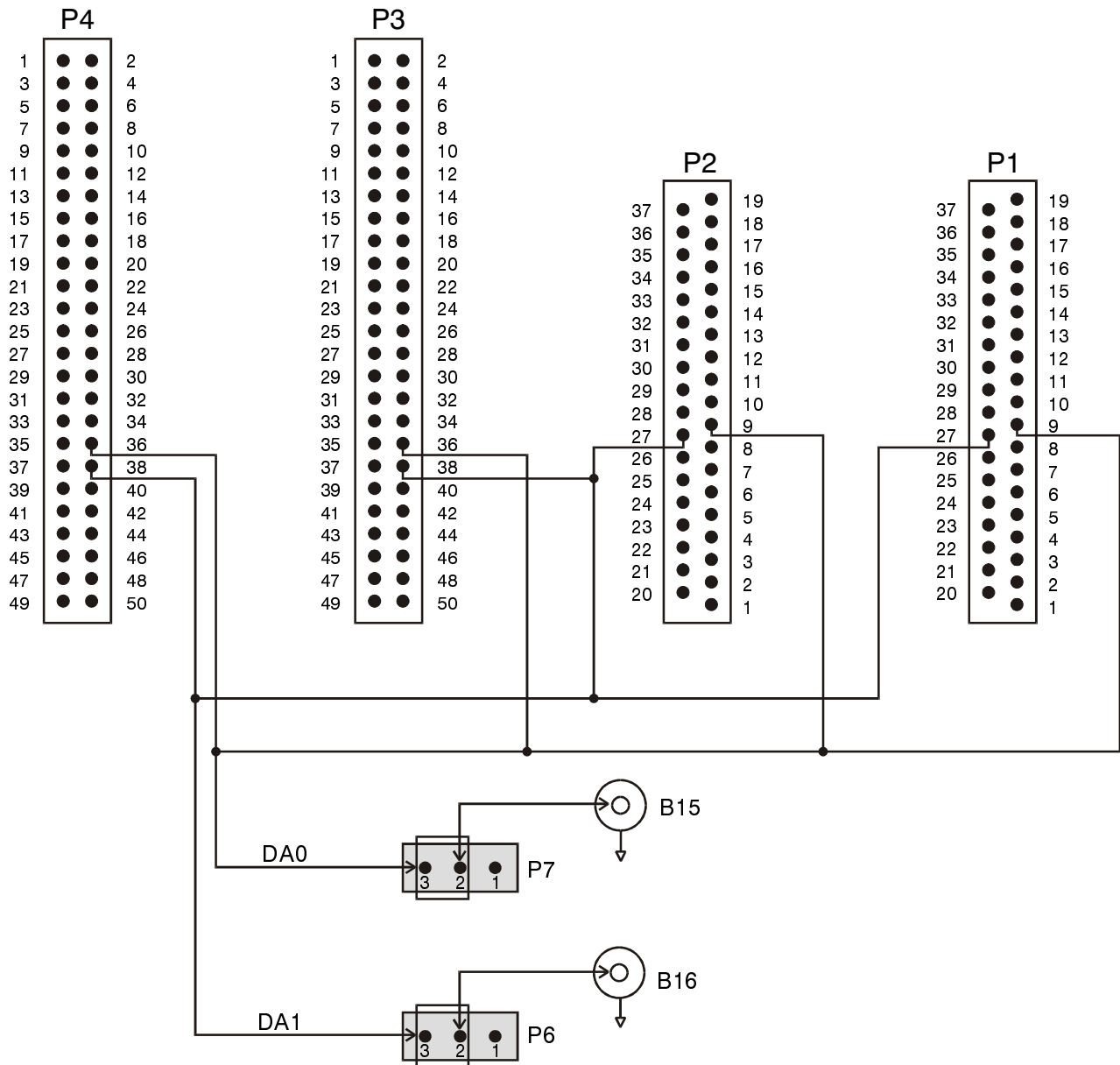

P1 CONNECTOR MAP

Connector P1 provides the user with a variety of I/O signals, not including the 16 analog input signals from B1-B16. The following diagram illustrates the connection scheme used to route these signals among connectors P2, P3 and P4 to connector P1. These signals are labeled "PASS" signals (except for the trigger and D/A options as shown) and the user should consult their DAS manual's I/O connector pin assignment section to verify the actual signals available at the P1 connector.

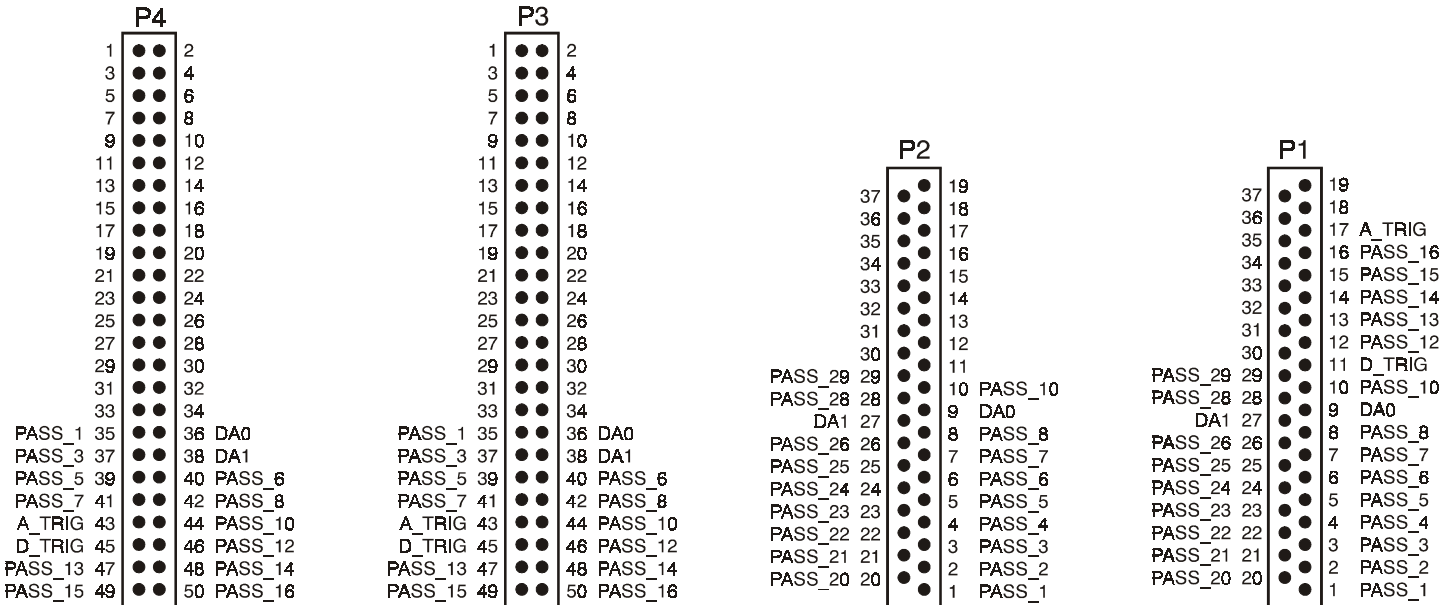

P1 Connector Map for BNC-16SE and BNC-16DI

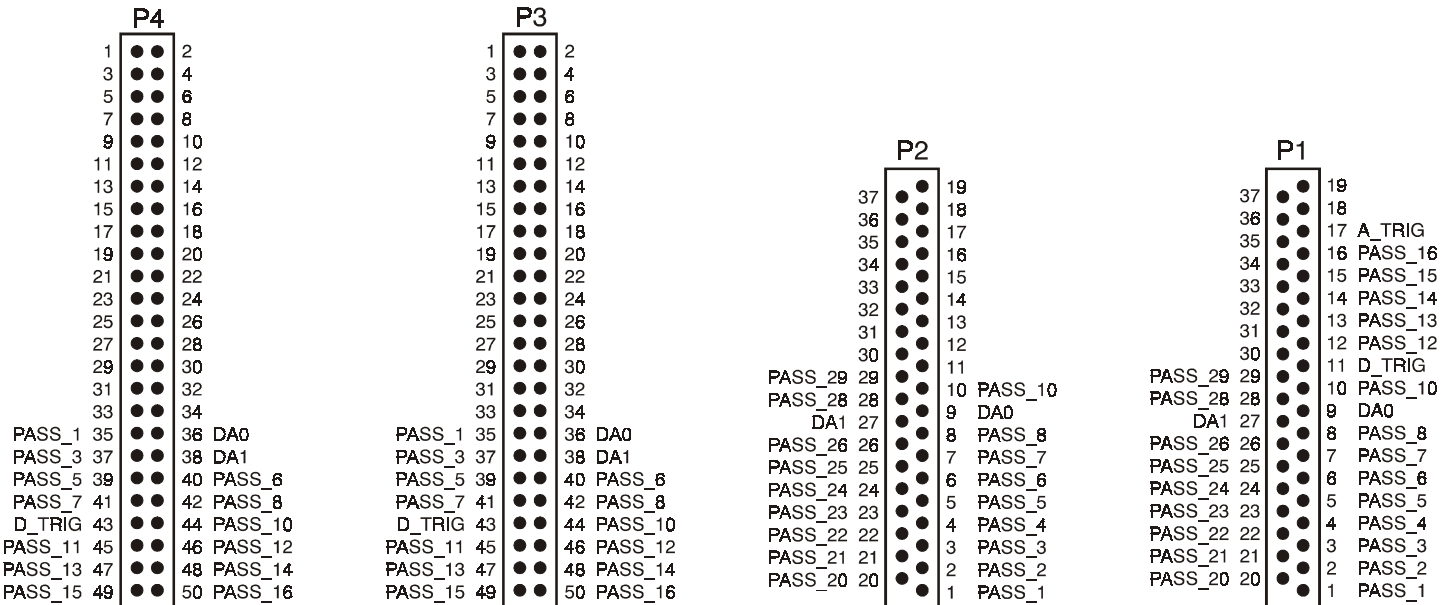

P1 Connector Map for BNC-16SE and BNC-16DI (CIO-DAS6402 series only)

Note: For CIO-DAS 6402 series, the digital trigger signal is on PIN43 of both P3 and P4, while PIN 45 of P3 and P4 is a "PASS" signal.

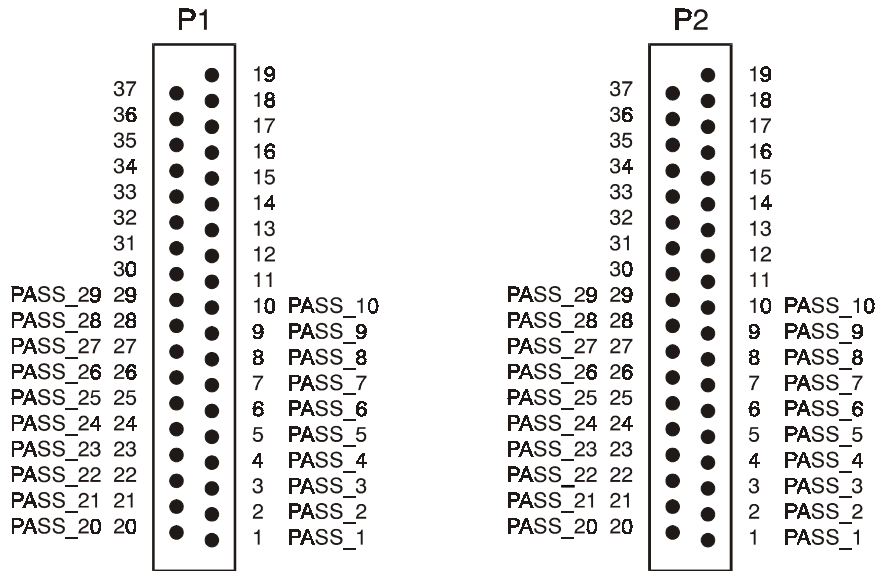

P1 Connector Map for BNC-08DI

BOARD COMPATIBILITY

The BNC-08DI is compatible with the following DAS boards:

DAS Boards	Input Configuration
CIO-DAS801	8 Differential Inputs
CIO-DAS802	8 Differential Inputs
CIO-DAS802/16	8 Differential Inputs
CIO-DAS08-AOH	8 Differential Inputs
CIO-DAS08-AOL	8 Differential Inputs
CIO-DAS08-AOM	8 Differential Inputs
CIO-DAS08-PGA	8 Differential Inputs
CIO-DAS08-PGH	8 Differential Inputs
CIO-DAS08-PGL	8 Differential Inputs
CIO-DAS08-PGM	8 Differential Inputs

The BNC-16DI and BNC-16SE are compatible with the following DAS boards:

Compatible Products (by series)	Input Configuration
CIO-DAS1400	DI and SE inputs
CIO-DAS1401	DI and SE inputs
CIO-DAS1402	DI and SE inputs
CIO-DAS6402	DI and SE inputs
CIO-DAS16	DI and SE inputs
CIO-DAS1601	DI and SE inputs
CIO-DAS1602	DI and SE inputs
CIO-DAS16/M1	DI inputs
PCI-DAS1001	DI and SE inputs
PCI-DAS1002	DI and SE inputs
PCI-DAS1200	DI and SE inputs
PCI-DAS16	DI and SE inputs
PCI-DAS1602	DI and SE inputs
PCI-DAS6402	DI and SE inputs

INPUT CONFIGURATIONS

Each BNC connector of the BNC-08/16DI and the BNC-16SE incorporates programmable, signal conditioning circuitry, which allows the user to connect a wide variety of options including filtering, bypassing, voltage division and termination. For situations where the factory installed shunt resistors RXA or RXB have been removed, solder gaps have been provided to quickly and easily reconnect these portions of the circuit.

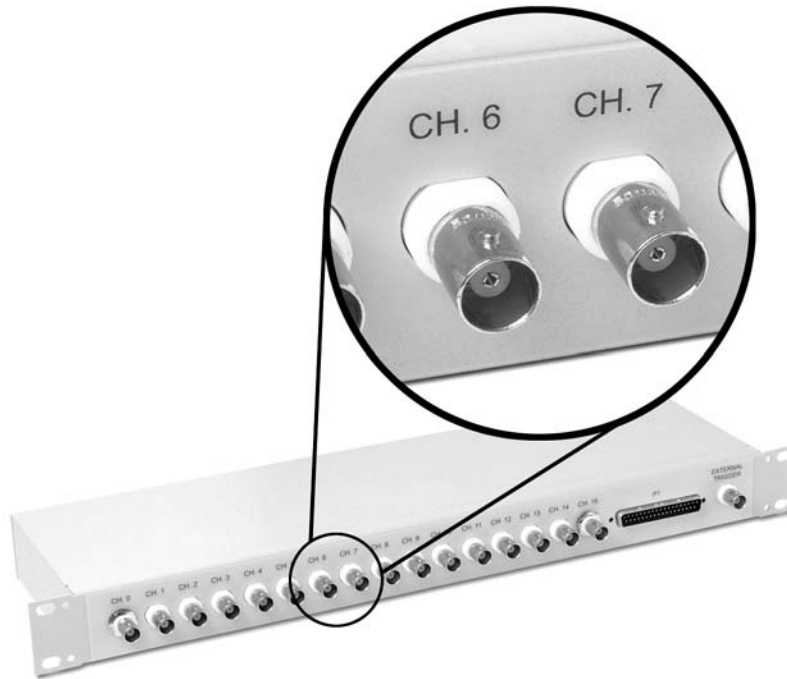

BNC-16SE Input Configuration

The following diagram illustrates the signal conditioning circuitry of a single-ended analog input channel used on the BNC-16SE.

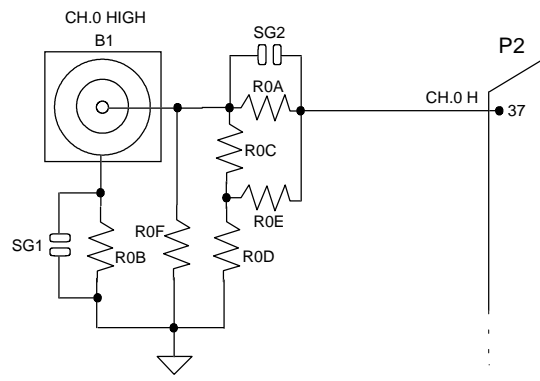

	Normal	R Divider	RC Filter	AC Couple	50 Ohm	Bypass
RXA*	0 ohm	open	open	capacitor	0 ohm	0 ohm
RXB*	0 ohm	0 ohm	0 ohm	0 ohm	0 ohm	0 ohm
RXC	open	resistor	resistor	open	open	0 ohm
RXD	open	resistor	capacitor	open	open	capacitor
RXE	open	0 ohm	0 ohm	open	open	open
RXF	open	open	open	open	resistor	open

*factory installed 0 ohm resistors

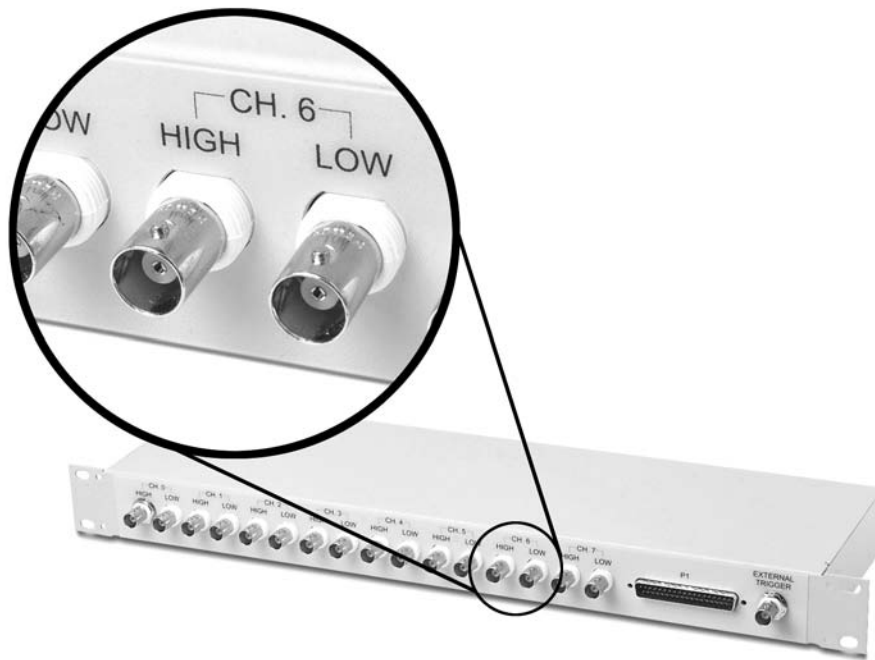

BNC08/16DI Input Configuration

The following diagram illustrates the signal conditioning circuitry of a differential analog input channels used on the BNC-16DI and the BNC-08DI.

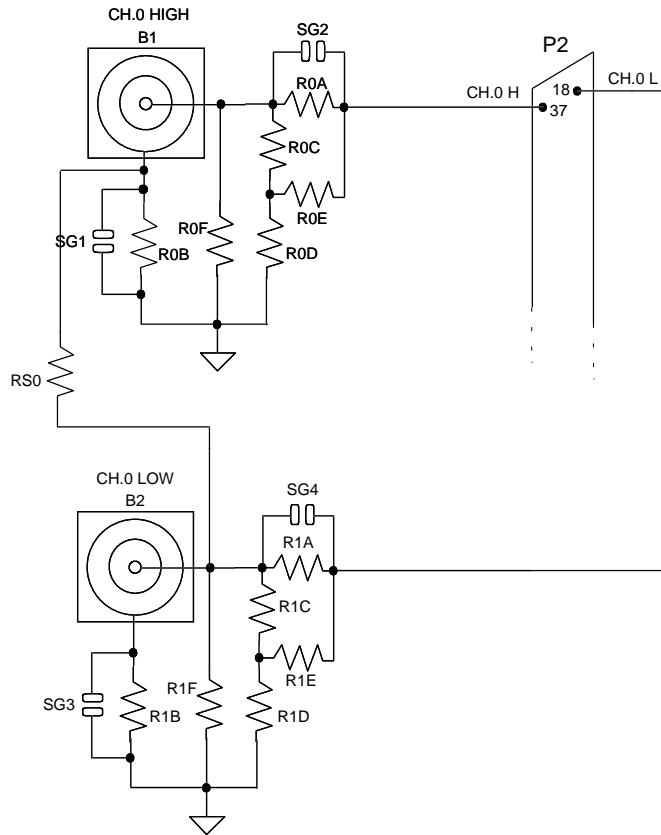

	Normal	R Divider	RC Filter	AC Couple	50 Ohm	Bypass
RXA*	0 ohm	open	open	capacitor	0 ohm	0 ohm
RXB*	0 ohm	0 ohm	0 ohm	0 ohm	0 ohm	0 ohm
RXC	open	resistor	resistor	open	open	0 ohm
RXD	open	resistor	capacitor	open	open	capacitor
RXE	open	0 ohm	0 ohm	open	open	open
RXF	open	open	open	open	resistor	open
RSX	resistor	resistor	resistor	resistor	resistor	resistor

*factory installed 0 ohm resistors

The following illustrations describe some common differential mode connection methods of the BNC-08/16DI enclosure. These are just a few of the many possible connection methods made possible using the programmable signal conditioning circuits.

1. Diagram A. describes a true differential setup utilizing a pair of coaxial cables. The grounding of the coaxial cable's shield at the enclosure end of the BNC cable is strictly an option.
2. Diagram B. describes a differential setup where the signal source and A/D board have isolated grounds. Resistor RSX has been provided for each pair of differential inputs to maintain a reference to ground. The grounding of the coaxial cable's shield at the enclosure end of the BNC cable is strictly an option.
3. Diagram C. describes a method of making a differential measurement using a single coaxial cable.

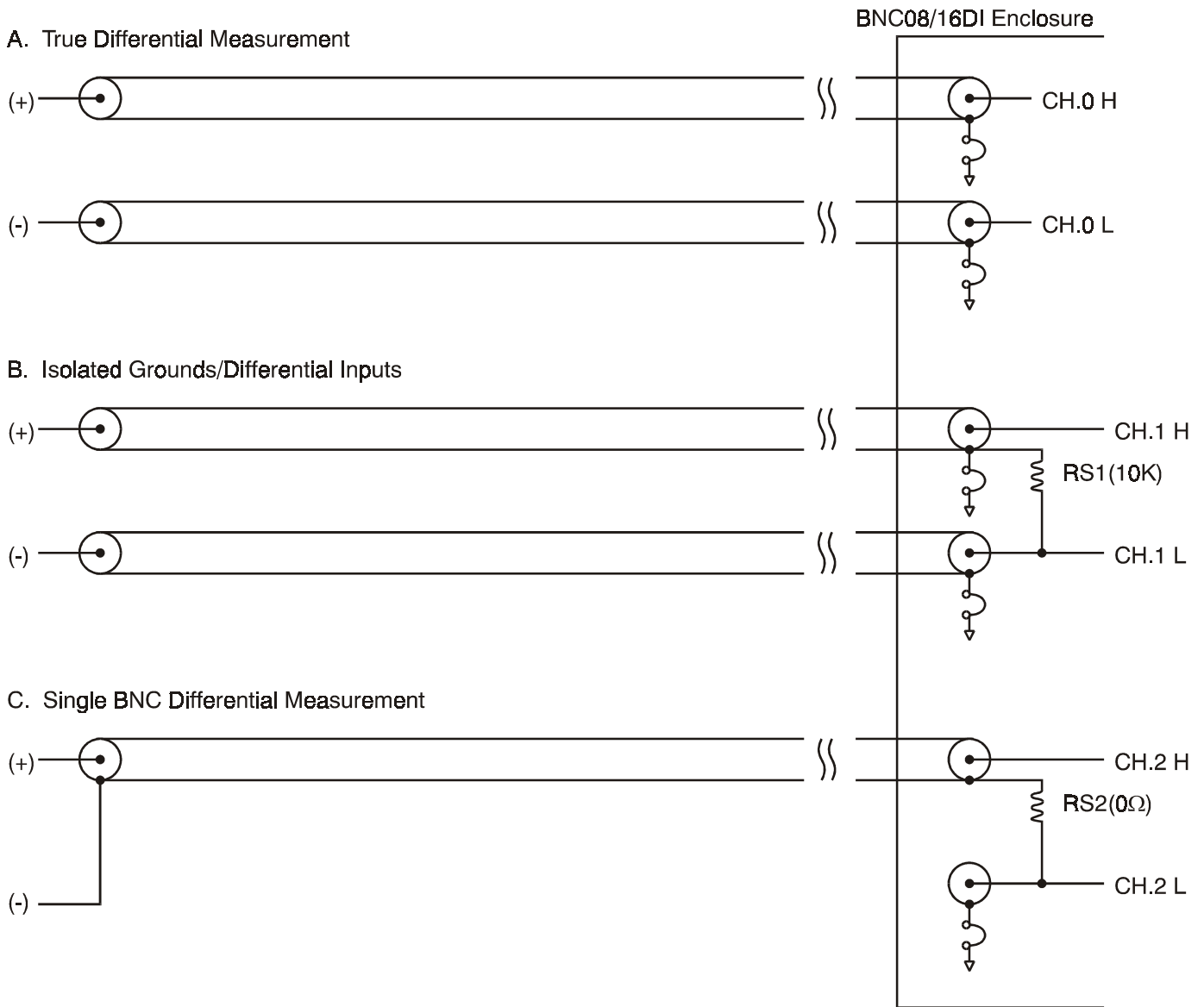

BOARD ACCESSIBILITY

Accessing the individual BNC input configuration circuits, or headers P6 or P7 (BNC-16SE, BNC16DI only) can be easily accomplished by removing the following hardware: enclosure screws (2), External Trigger nut and washer, and P2 set screws (2).

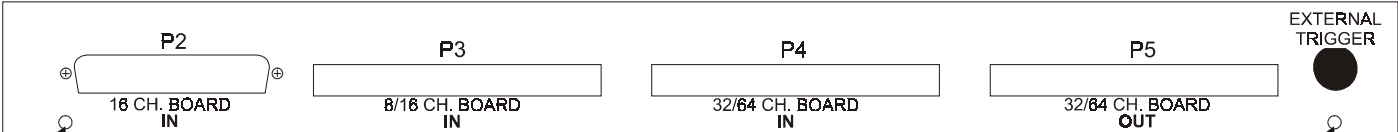

BNC-16SE, BNC-16DI



BNC-08DI

EC Declaration of Conformity

We, O gcuwtgo gpv'Ego r wkp'i 'Eqtr qtcv'kqp, declare under sole responsibility that the product:

BNC 08/16DI	BNC Boxes
BNC 16SE	
Part Number	Description

to which this declaration relates, meets the essential requirements, is in conformity with, and CE marking has been applied according to the relevant EC Directives listed below using the relevant section of the following EC standards and other normative documents:

EU EMC Directive 89/336/EEC: Essential requirements relating to electromagnetic compatibility.

EU 55022 Class B: Limits and methods of measurements of radio interference characteristics of information technology equipment.

EN 50082-1: EC generic immunity requirements.

IEC 801-2: Electrostatic discharge requirements for industrial process measurement and control equipment.

IEC 801-3: Radiated electromagnetic field requirements for industrial process measurements and control equipment.

IEC 801-4: Electrically fast transients for industrial process measurement and control equipment.

Carl Haapaoja, Director of Quality Assurance

Measurement Computing Corporation
10 Commerce Way
Suite 1008
Norton, Massachusetts 02766
(508) 946-5100
Fax: (508) 946-9500
E-mail: info@mccdaq.com
www.mccdaq.com